

Wide Band GaAs MMIC Amplifier 2.0 - 8.0 GHz

Rev. V8

Features

- Gain: 17 dB Typical
- Broadband Gain Flatness: ± 0.5 dB Typical
- Single Supply: +10 V
- No External Components Required
- DC Decoupled RF Input and Output
- Lead-Free 8-Lead Ceramic Package
- RoHS* Compliant and 260°C Reflow Compatible

Description

The MAAM28000-A1 is a wide band, MMIC amplifier housed in a small, lead-free, 8-lead ceramic package. It includes two distributed gain stages to obtain flat gain and a good, 50-ohm input and output impedance match over a very wide bandwidth. The MAAM28000-A1 operates from a single +10 V supply. It is fully monolithic, requires no external components and is provided in a low-cost, user-friendly, microwave package.

The MAAM28000-A1 performs well as a generic IF, driver or buffer amplifier where high gain, excellent linearity and low power consumption are important. Because of its wide bandwidth, the MAAM28000-A1 can be used in numerous commercial and government system applications, such as satellite communications, RLL, EW and radar.

The MAAM28000-A1 is manufactured in-house using a reliable, 0.5-micron, GaAs MESFET process. This product is 100% RF tested to ensure compliance to performance specifications.

Ordering Information

Part Number	Package
MAAM28000-A1	8-lead Ceramic (CR-3)
MAAM28000-A1G	Gull Wing (CR-10)

Schematic

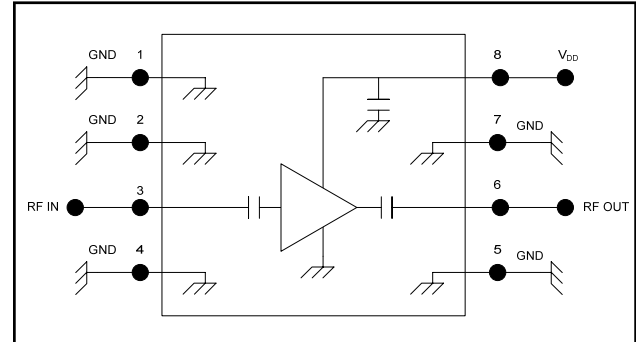

Pin Configuration¹

Pin No.	Function	Pin No.	Function
1	Ground	5	Ground
2	Ground	6	RF Output
3	RF Input	7	Ground
4	Ground	8	V _{DD}

1. The package bottom must be connected to RF and DC ground.

Absolute Maximum Ratings^{2,3}

Parameter	Absolute Maximum
V _{DD}	+14 V
Input Power	+20 dBm
Current	150 mA
Channel Temperature	+150°C
Operating Temperature ⁴	-55°C to +100°C
Storage Temperature	-65°C to +150°C

2. Exceeding any one or combination of these limits may cause permanent damage to this device.
3. M/A-COM Technology does not recommend sustained operation near these survivability limits.
4. Typical thermal resistance (θ_{jc}) = +45°C/W

* Restrictions on Hazardous Substances, European Union Directive 2002/95/EC.

Lead-Free CR-10 (MAAM28000-A1G)[†]

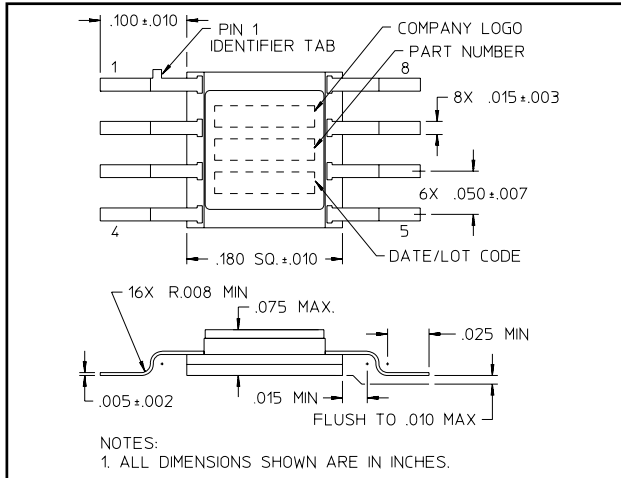

Lead-Free CR-3 (MAAM28000-A1)[†]

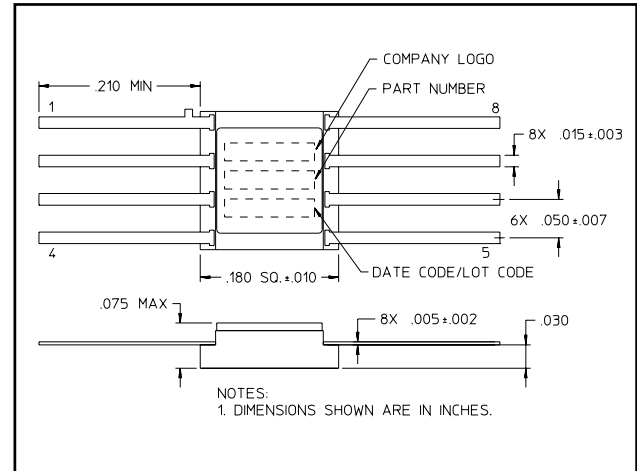

[†] Reference Application Note M538 for lead-free solder reflow recommendations.
Meets JEDEC moisture sensitivity level 1 requirements.

Electrical Specifications: $T_A = 25^\circ\text{C}$, $V_{DD} = +10\text{ V}$, $Z_0 = 50\ \Omega$

Parameter	Test Conditions	Units	Min.	Typ.	Max.
Gain	2.0 - 8.0 GHz, $P_{IN} = -30\text{ dBm}$	dB	14	17	—
Noise Figure	2.0 - 4.0 GHz	dB	—	6.5	8.0
	4.0 - 6.0 GHz	dB	—	5.5	6.5
	6.0 - 8.0 GHz	dB	—	4.5	6.0
Gain Flatness	2.0 - 8.0 GHz, $P_{IN} = -30\text{ dBm}$	dB	—	± 0.5	—
Input VSWR	2.0 - 8.0 GHz, $P_{IN} = -30\text{ dBm}$	Ratio	—	1.6:1	—
	Output VSWR	2.0 - 8.0 GHz, $P_{IN} = -30\text{ dBm}$	Ratio	—	1.5:1
Output 1 dB Compression	2.0 - 8.0 GHz	dBm	—	+14	—
Input IP3	2.0 - 8.0 GHz, $P_{IN} = -30\text{ dBm}$	dBm	—	+7	—
Reverse Isolation	2.0 - 8.0 GHz, $P_{IN} = -30\text{ dBm}$	dB	—	35	—
Bias Current	—	mA	—	70	100

Typical Performance Curves

Gain

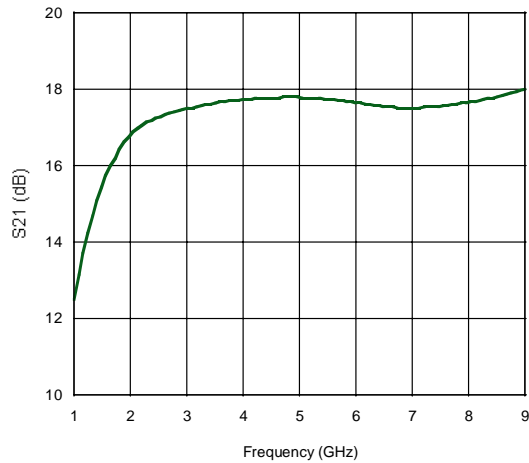

Noise Figure

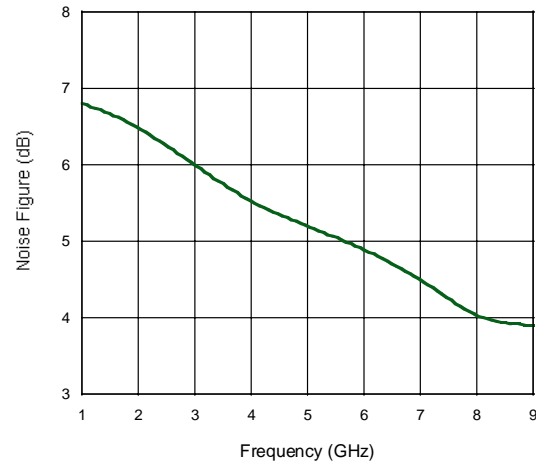

VSWR

