

2.5 A OUTPUT CURRENT, HIGH CMR  
IGBT GATE DRIVE  
8-PIN SDIP PHOTOCOUPLER

–NEPOC Series–

**DESCRIPTION**

The PS9302L is an optically coupled isolator containing a GaAlAs LED on the input side and a photo diode, a signal processing circuit and a power output transistor on the output side on one chip.

The PS9302L is designed specifically for high common mode transient immunity (CMR), high output current and high switching speed.

**FEATURES**

- Large peak output current (2.5 A MAX., 2.0 A MIN.)
- High speed switching ( $t_{PLH}$ ,  $t_{PHL}$  = 0.5  $\mu$ S MAX.)
- Long creepage distance (8 mm MIN.)
- UVLO (Under Voltage Lock Out) protection with hysteresis
- High common mode transient immunity ( $CM_H$ ,  $CM_L$  =  $\pm 25$  kV/ $\mu$ S MIN.)
- <R> • Ordering number of tape product: PS9302L-E3: 2 000 pcs/reel
- Pb-Free product
- <R> • Safety standards
  - UL approved: No. E72422
  - CSA approved: No. CA 101391 (CA5A, CAN/CSA-C22.2 60065, 60950)
  - DIN EN60747-5-2 (VDE0884 Part2) approved: No. 40019182 (Option)

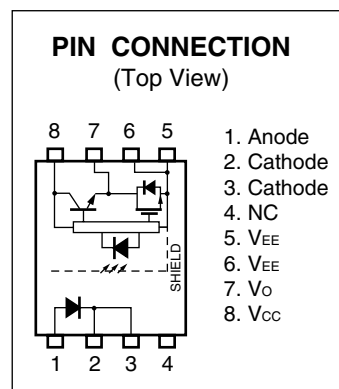

**APPLICATIONS**

- IGBT, Power MOS FET Gate Driver
- Industrial inverter
- IH (Induction Heating)

The information in this document is subject to change without notice. Before using this document, please confirm that this is the latest version.  
Not all products and/or types are available in every country. Please check with an NEC Electronics sales representative for availability and additional information.

PACKAGE DIMENSIONS (UNIT: mm)

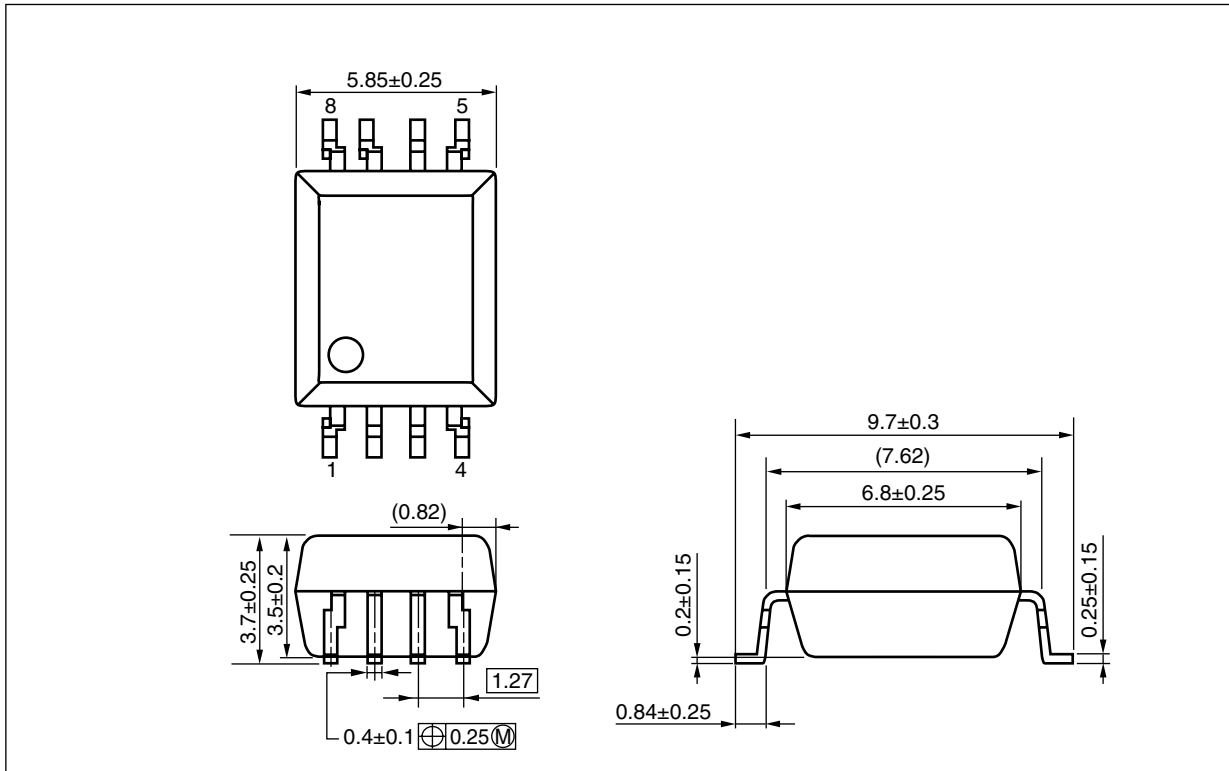

**FUNCTIONAL DIAGRAM**

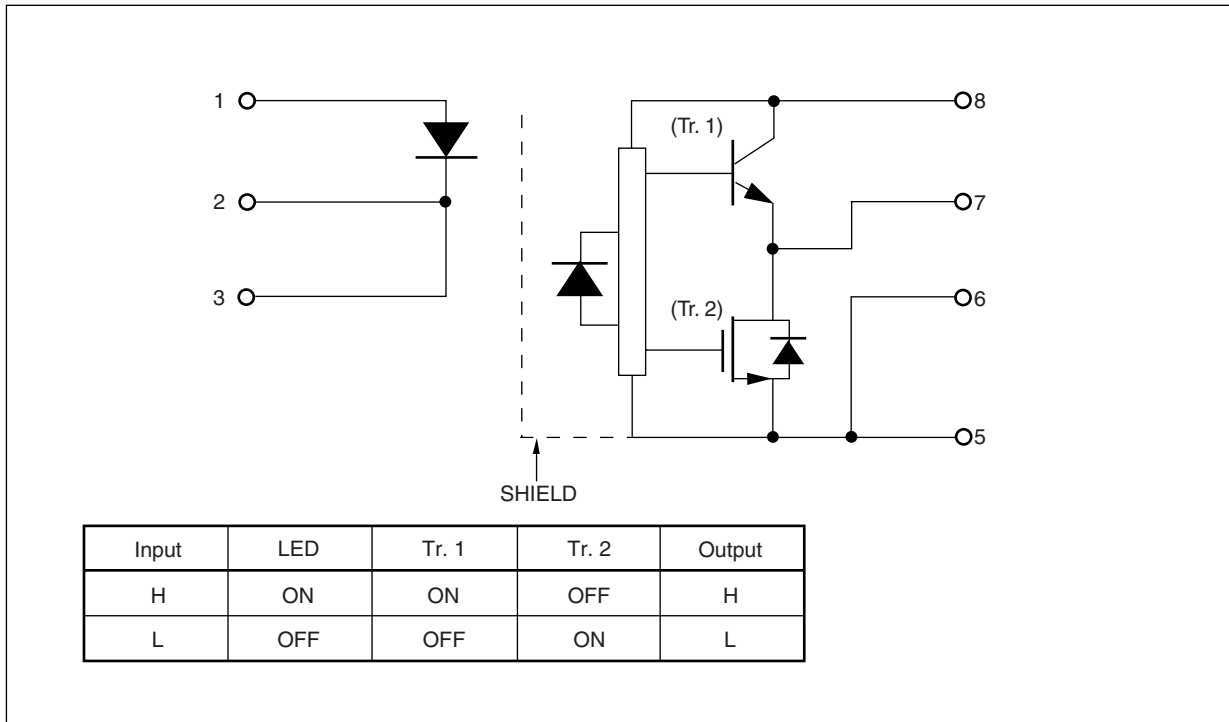

**MARKING EXAMPLE**

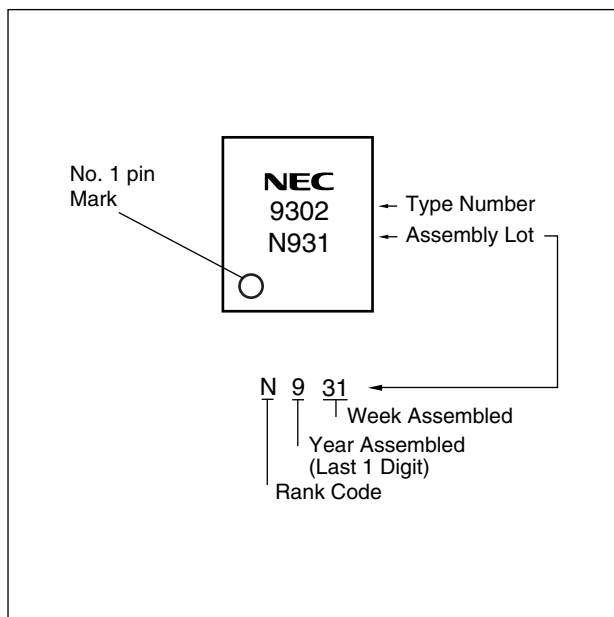

**PHOTOCOUPLER CONSTRUCTION**

Parameter	PS9302L
Air Distance (MIN.)	7 mm
Outer Creepage Distance (MIN.)	8 mm
Isolation Distance (MIN.)	0.4 mm

<R> ORDERING INFORMATION

Part Number	Order Number	Solder Plating Specification	Packing Style	Safety Standard Approval	Application Part Number <sup>*1</sup>
PS9302L	PS9302L-AX	Pb-Free (Ni/Pd/Au)	20 pcs (Tape 20 pcs cut)	Standard products (UL, CSA approved)	PS9302L
PS9302L-E3	PS9302L-E3-AX		Embossed Tape 2 000 pcs/reel		
PS9302L-V	PS9302L-V-AX		20 pcs (Tape 20 pcs cut)	DIN EN60747-5-2	
PS9302L-V-E3	PS9302L-V-E3-AX		Embossed Tape 2 000 pcs/reel	(VDE0884 Part2) Approved (Option)	

\*1 For the application of the Safety Standard, following part number should be used.

ABSOLUTE MAXIMUM RATINGS (T<sub>A</sub> = 25°C, unless otherwise specified)

Parameter		Symbol	Ratings	Unit
Diode	Forward Current	I <sub>F</sub>	25	mA
	Peak Transient Forward Current (Pulse Width < 1 μs)	I <sub>F (TRAN)</sub>	1.0	A
	Reverse Voltage	V <sub>R</sub>	5	V
	Power Dissipation <sup>*1</sup>	P <sub>D</sub>	45	mW
Detector	High Level Peak Output Current <sup>*2</sup>	I <sub>OH (PEAK)</sub>	2.5	A
	Low Level Peak Output Current <sup>*2</sup>	I <sub>OL (PEAK)</sub>	2.5	A
	Supply Voltage	(V <sub>CC</sub> - V <sub>EE</sub> )	0 to 35	V
	Output Voltage	V <sub>O</sub>	0 to V <sub>CC</sub>	V
	Power Dissipation <sup>*3</sup>	P <sub>C</sub>	250	mW
Isolation Voltage <sup>*4</sup>		BV	5 000	Vr.m.s.
Operating Frequency <sup>*5</sup>		f	50	kHz
Operating Ambient Temperature		T <sub>A</sub>	-40 to +100	°C
Storage Temperature		T <sub>stg</sub>	-55 to +125	°C

\*1 Reduced to 1.6 mW/°C at T<sub>A</sub> = 85°C or more.

\*2 Maximum pulse width = 10 μs, Maximum duty cycle = 0.2%

\*3 Reduced to 6.0 mW/°C at T<sub>A</sub> = 80°C or more.

\*4 AC voltage for 1 minute at T<sub>A</sub> = 25°C, RH = 60% between input and output.

Pins 1-4 shorted together, 5-8 shorted together.

\*5 I<sub>OH (PEAK)</sub> ≤ 2.0 A (≤ 0.3 μs), I<sub>OL (PEAK)</sub> ≤ 2.0 A (≤ 0.3 μs)

<R>

**RECOMMENDED OPERATING CONDITIONS**

Parameter	Symbol	MIN.	TYP.	MAX.	Unit
Supply Voltage	(V <sub>CC</sub> - V <sub>EE</sub> )	15		30	V
Forward Current (ON)	I <sub>F (ON)</sub>	7	10	16	mA
Forward Voltage (OFF)	V <sub>F (OFF)</sub>	-2		0.8	V
Operating Ambient Temperature	T <sub>A</sub>	-40		100	°C

**ELECTRICAL CHARACTERISTICS (T<sub>A</sub> = -40 to +100°C, V<sub>CC</sub> = 15 to 30 V, I<sub>F (ON)</sub> = 7 to 16 mA, V<sub>F (OFF)</sub> = -2 to 0.8 V, V<sub>EE</sub> = GND, unless otherwise specified)**

Parameter		Symbol	Conditions	MIN.	TYP.*1	MAX.	Unit
Diode	Forward Voltage	V <sub>F</sub>	I <sub>F</sub> = 10 mA, T <sub>A</sub> = 25°C	1.2	1.56	1.9	V
	Reverse Current	I <sub>R</sub>	V <sub>R</sub> = 3 V, T <sub>A</sub> = 25°C			10	μA
	Terminal Capacitance	C <sub>t</sub>	f = 1 MHz, V <sub>F</sub> = 0 V, T <sub>A</sub> = 25°C		30		pF
Detector	High Level Output Current	I <sub>OH</sub>	V <sub>O</sub> = (V <sub>CC</sub> - 4 V) <sup>2</sup>	0.5	2.0		A
			V <sub>O</sub> = (V <sub>CC</sub> - 15 V) <sup>3</sup>	2.0			
	Low Level Output Current	I <sub>OL</sub>	V <sub>O</sub> = (V <sub>EE</sub> + 2.5 V) <sup>2</sup>	0.5	2.0		A
			V <sub>O</sub> = (V <sub>EE</sub> + 15 V) <sup>3</sup>	2.0			
	High Level Output Voltage	V <sub>OH</sub>	I <sub>O</sub> = -100 mA <sup>4</sup>	V <sub>CC</sub> - 3.5	V <sub>CC</sub> - 2.5	V <sub>CC</sub> - 1.5	V
	Low Level Output Voltage	V <sub>OL</sub>	I <sub>O</sub> = 100 mA		0.1	0.5	V
	High Level Supply Current	I <sub>CCH</sub>	V <sub>O</sub> = open, I <sub>F</sub> = 10 mA		2.0	3.5	mA
	Low Level Supply Current	I <sub>CCL</sub>	V <sub>O</sub> = open, V <sub>F</sub> = 0 to +0.8 V		2.0	3.0	mA
	UVLO Threshold	V <sub>UVLO+</sub> V <sub>UVLO-</sub>	V <sub>O</sub> > 5 V, I <sub>F</sub> = 10 mA	11.0	12.0	13.5	V
9.5				11.0	12.0		
UVLO Hysteresis	UVLO <sub>HYS</sub>	V <sub>O</sub> > 5 V, I <sub>F</sub> = 10 mA		1.0		V	
Coupled	Threshold Input Current (L → H)	I <sub>FLH</sub>	I <sub>O</sub> = 0 mA, V <sub>O</sub> > 5 V		2.0	5.0	mA
	Threshold Input Voltage (H → L)	V <sub>FHL</sub>	I <sub>O</sub> = 0 mA, V <sub>O</sub> < 5 V	0.8			V

\*1 Typical values at T<sub>A</sub> = 25°C.

\*2 Maximum pulse width = 50 μs, Maximum duty cycle = 0.5%.

\*3 Maximum pulse width = 10 μs, Maximum duty cycle = 0.2%

\*4 V<sub>OH</sub> is measured with the DC load current in this testing (Maximum pulse width = 2 ms, Maximum duty cycle = 20%).

**SWITCHING CHARACTERISTICS** ( $T_A = -40$  to  $+100^\circ\text{C}$ ,  $V_{CC} = 15$  to  $30$  V,  $I_F(\text{ON}) = 7$  to  $16$  mA,  $V_F(\text{OFF}) = -2$  to  $0.8$  V,  $V_{EE} = \text{GND}$ , unless otherwise specified)

Parameter	Symbol	Conditions	MIN.	TYP.*1	MAX.	Unit
Propagation Delay Time (L → H)	$t_{PLH}$	$R_g = 10 \Omega$ , $C_g = 10 \text{ nF}$ , $f = 10 \text{ kHz}$ , Duty Cycle = 50% <sup>*2</sup> , $I_F = 10 \text{ mA}$	0.1	0.3	0.5	$\mu\text{s}$
Propagation Delay Time (H → L)	$t_{PHL}$		0.1	0.3	0.5	$\mu\text{s}$
Pulse Width Distortion (PWD)	$ t_{PHL} - t_{PLH} $				0.3	$\mu\text{s}$
Propagation Delay Time (Difference Between Any Two Products)	$t_{PHL} - t_{PLH}$		-0.35		0.35	$\mu\text{s}$
Rise Time	$t_r$			0.1		$\mu\text{s}$
Fall Time	$t_f$			0.1		$\mu\text{s}$
UVLO (Turn On Delay)	$t_{UVLO \text{ ON}}$	$V_o > 5 \text{ V}$ , $I_F = 10 \text{ mA}$		0.8		$\mu\text{s}$
UVLO (Turn Off Delay)	$t_{UVLO \text{ OFF}}$	$V_o < 5 \text{ V}$ , $I_F = 10 \text{ mA}$		0.6		$\mu\text{s}$
Common Mode Transient Immunity at High Level Output <sup>*3</sup>	$ CM_H $	$T_A = 25^\circ\text{C}$ , $I_F = 10 \text{ mA}$ , $V_{CC} = 30 \text{ V}$ , $V_{O(\text{MIN.})} = 26 \text{ V}$ , $V_{CM} = 1.5\text{k V}$	25			$\text{kV}/\mu\text{s}$
Common Mode Transient Immunity at Low Level Output <sup>*3</sup>	$ CM_L $	$T_A = 25^\circ\text{C}$ , $I_F = 0 \text{ mA}$ , $V_{CC} = 30 \text{ V}$ , $V_{O(\text{MAX.})} = 1 \text{ V}$ , $V_{CM} = 1.5\text{k V}$	25			$\text{kV}/\mu\text{s}$

\*1 Typical values at  $T_A = 25^\circ\text{C}$ .

\*2 This load condition is equivalent to the IGBT load at 1 200 V/75 A.

\*3 Connect pin 4 to the LED common.

<R> TEST CIRCUIT

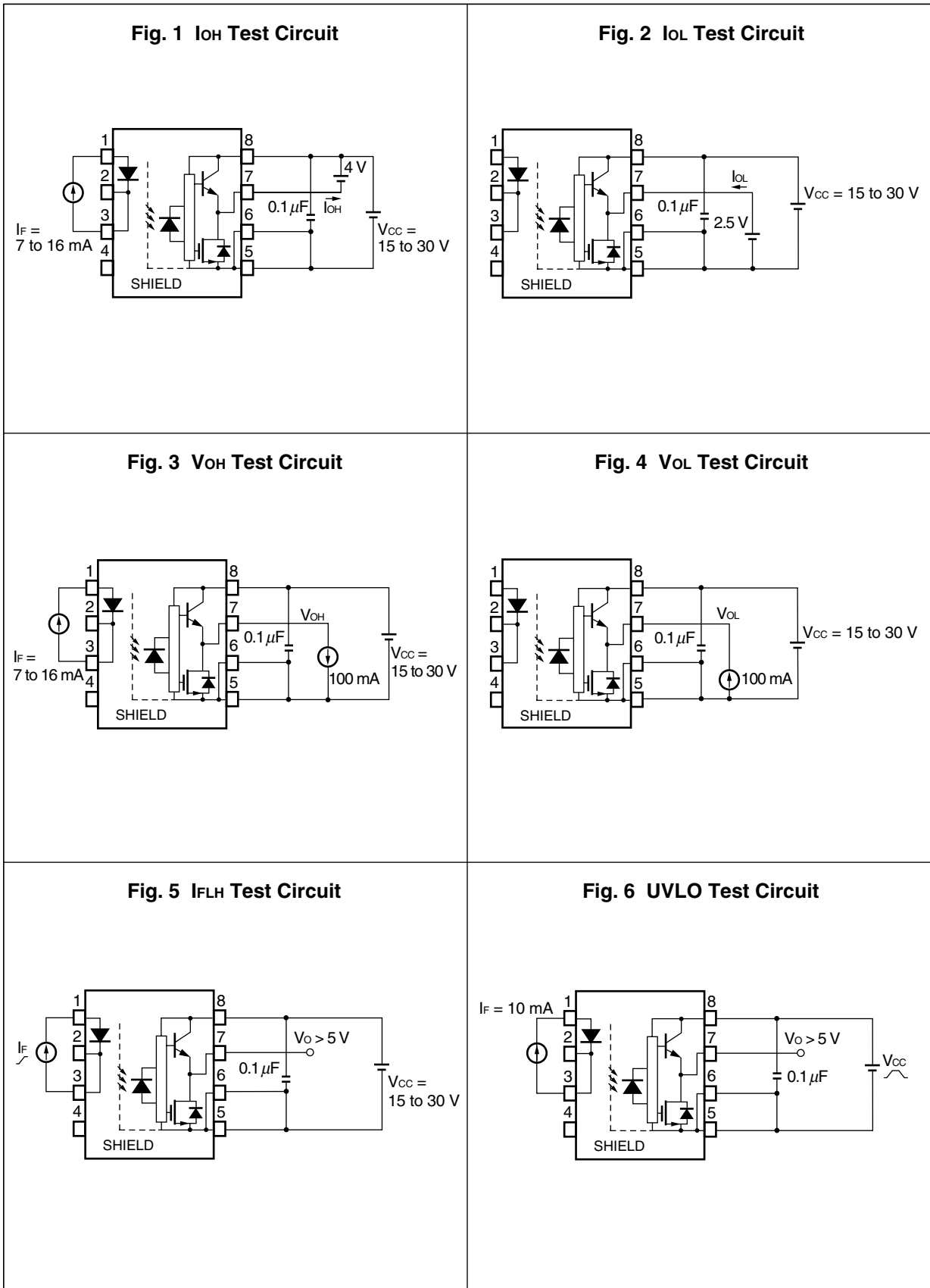

Fig. 7  $t_{PLH}$ ,  $t_{PHL}$ ,  $t_r$ ,  $t_f$  Test Circuit and Wave Forms

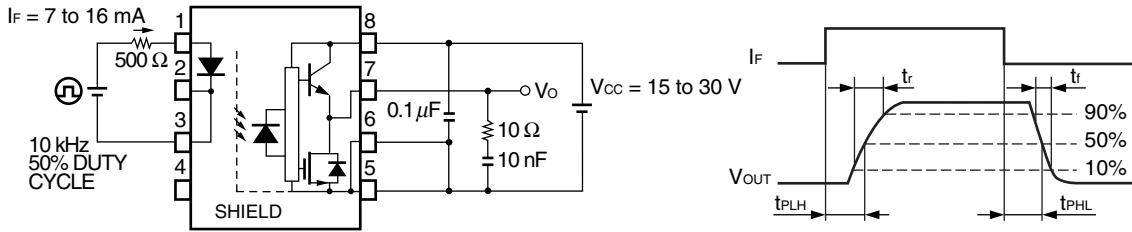
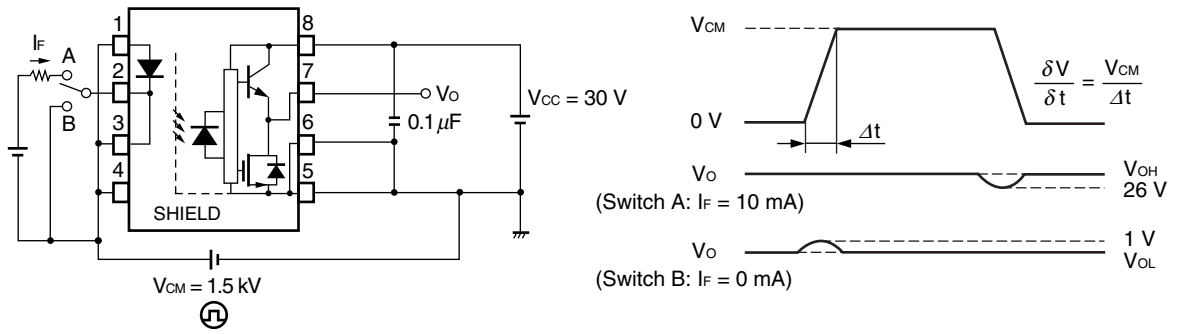

Fig. 8 CMR Test Circuit and Wave Forms





<R> **TYPICAL CHARACTERISTICS (T<sub>A</sub> = 25°C, unless otherwise specified)**

**DIODE POWER DISSIPATION vs. AMBIENT TEMPERATURE**

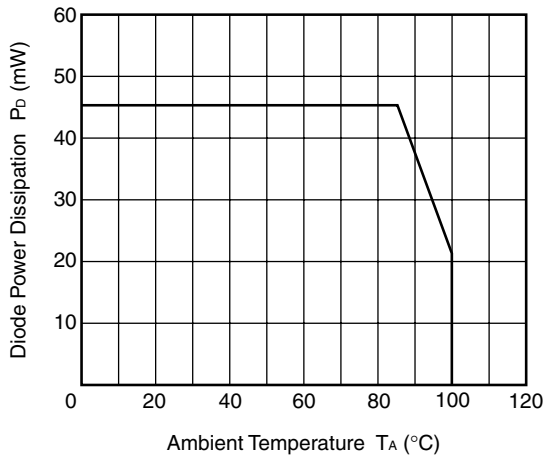

**DETECTOR POWER DISSIPATION vs. AMBIENT TEMPERATURE**

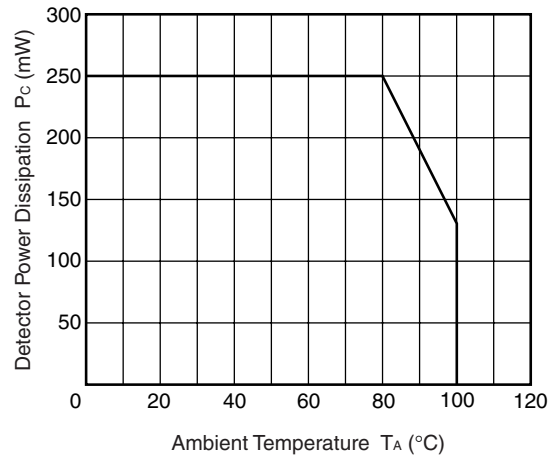

**FORWARD CURRENT vs. FORWARD VOLTAGE**

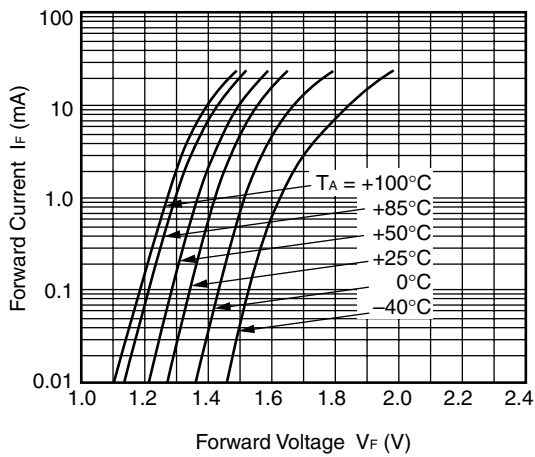

**THRESHOLD INPUT CURRENT vs. AMBIENT TEMPERATURE**

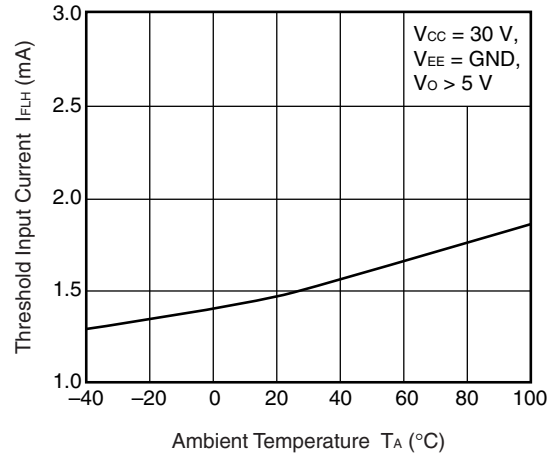

**OUTPUT VOLTAGE vs. FORWARD CURRENT**

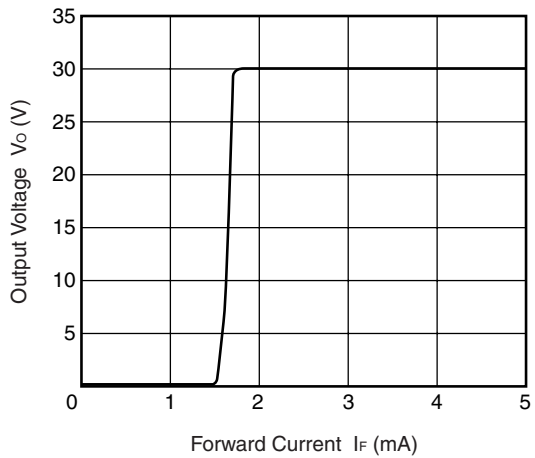

**HIGH LEVEL OUTPUT VOLTAGE – SUPPLY VOLTAGE vs. HIGH LEVEL OUTPUT CURRENT**

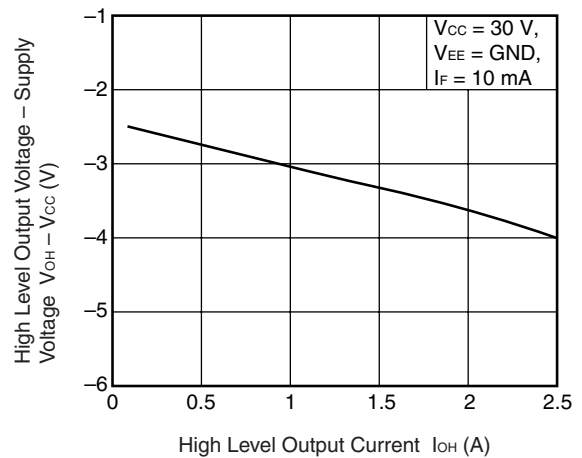

**Remark** The graphs indicate nominal characteristics.

LOW LEVEL OUTPUT VOLTAGE vs. LOW LEVEL OUTPUT CURRENT

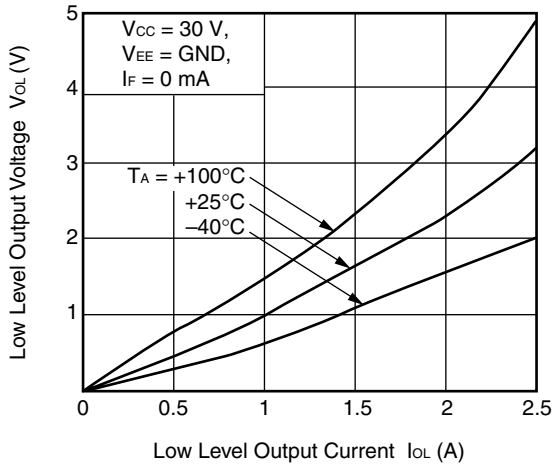

PROPAGATION DELAY TIME, PULSE WIDTH DISTORTION vs. FORWARD CURRENT

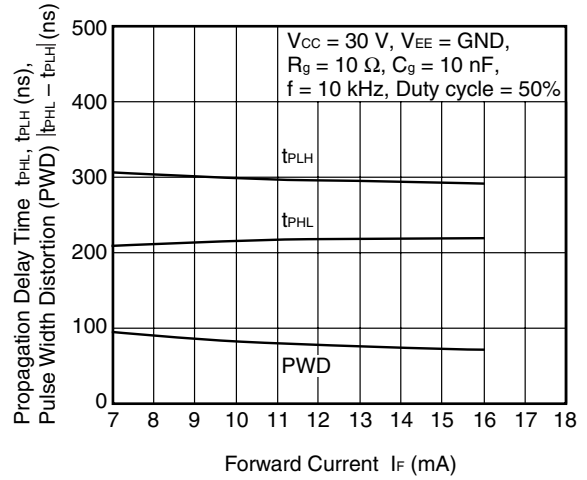

PROPAGATION DELAY TIME, PULSE WIDTH DISTORTION vs. SUPPLY VOLTAGE

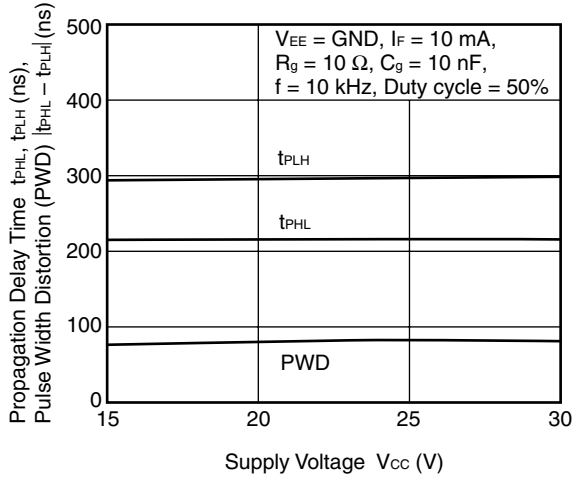

PROPAGATION DELAY TIME, PULSE WIDTH DISTORTION vs. AMBIENT TEMPERATURE

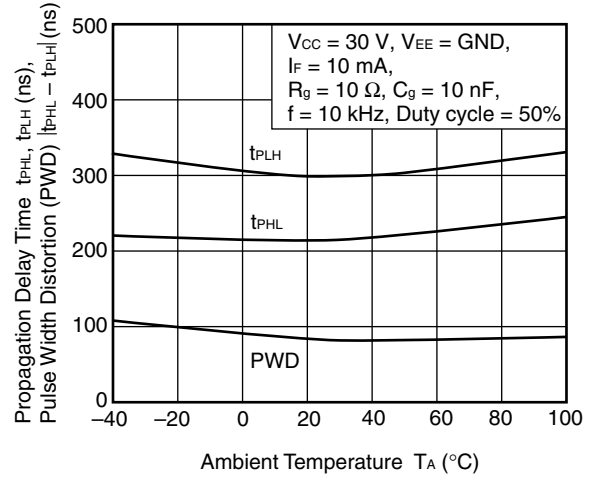

PROPAGATION DELAY TIME, PULSE WIDTH DISTORTION vs. LOAD CAPACITANCE

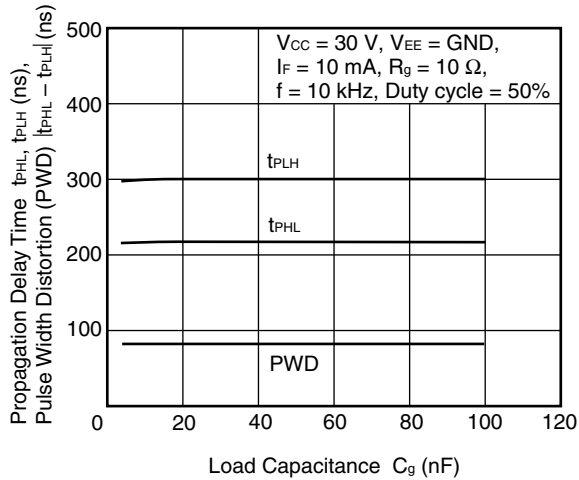

SUPPLY CURRENT vs. AMBIENT TEMPERATURE

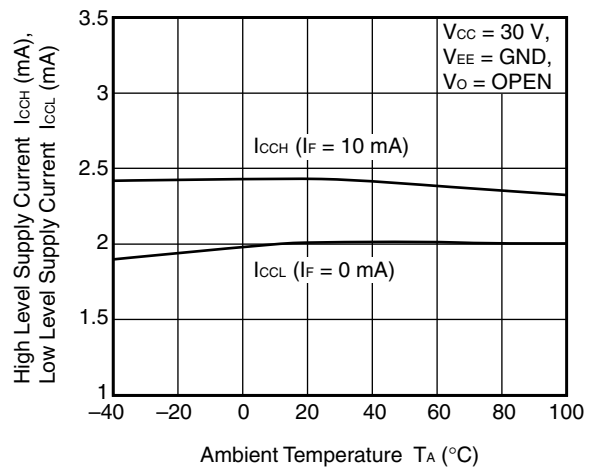

**Remark** The graphs indicate nominal characteristics.

SUPPLY CURRENT vs. AMBIENT TEMPERATURE

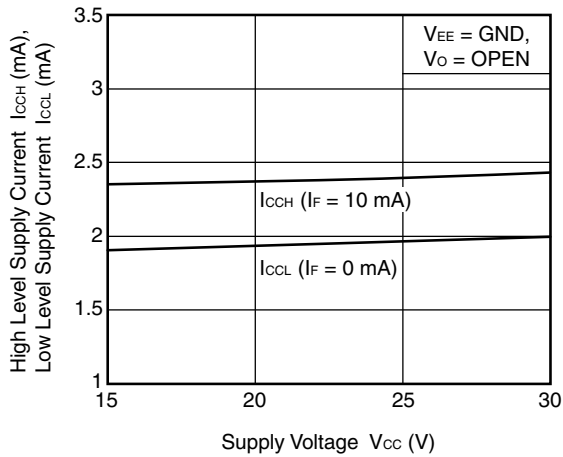

HIGH LEVEL OUTPUT VOLTAGE – SUPPLY VOLTAGE vs. AMBIENT TEMPERATURE

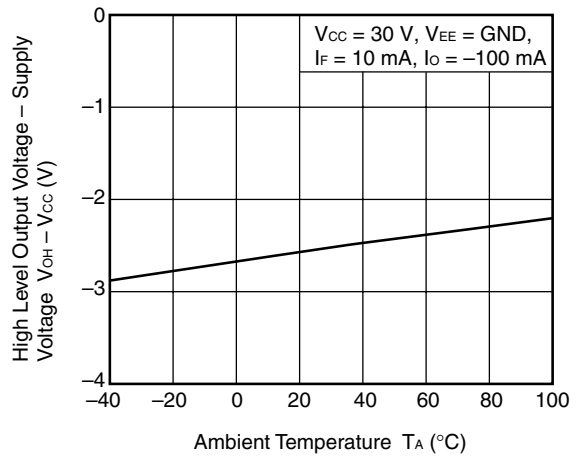

LOW LEVEL OUTPUT VOLTAGE vs. AMBIENT TEMPERATURE

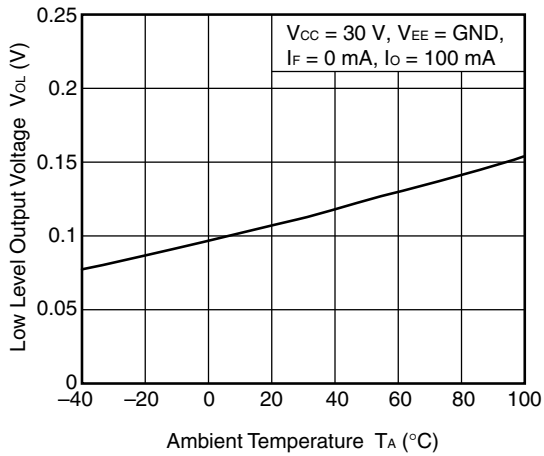

HIGH LEVEL OUTPUT CURRENT vs. AMBIENT TEMPERATURE

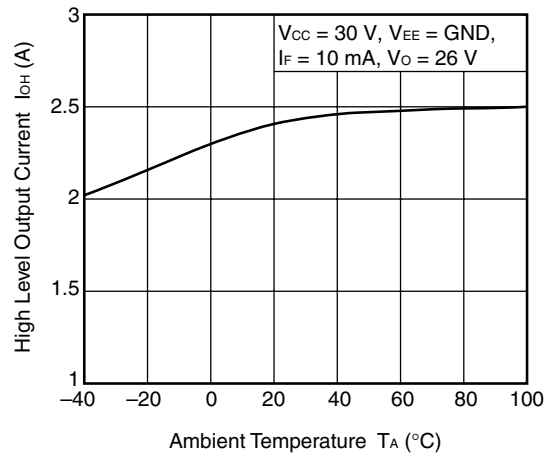

LOW LEVEL OUTPUT CURRENT vs. AMBIENT TEMPERATURE

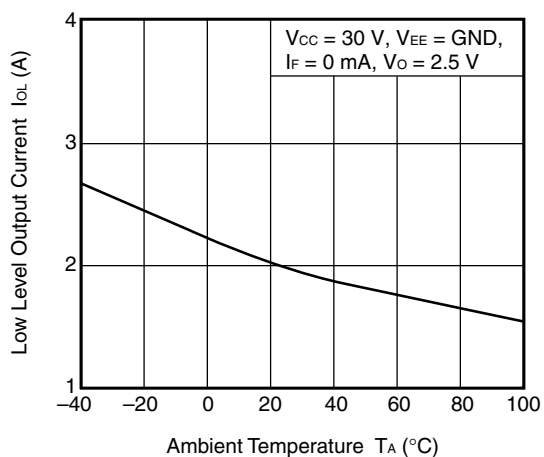

PROPAGATION DELAY TIME, PULSE WIDTH DISTORTION vs. LOAD RESISTANCE

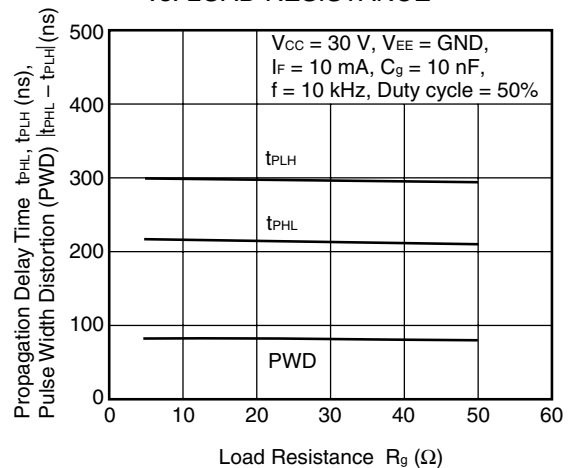

**Remark** The graphs indicate nominal characteristics.

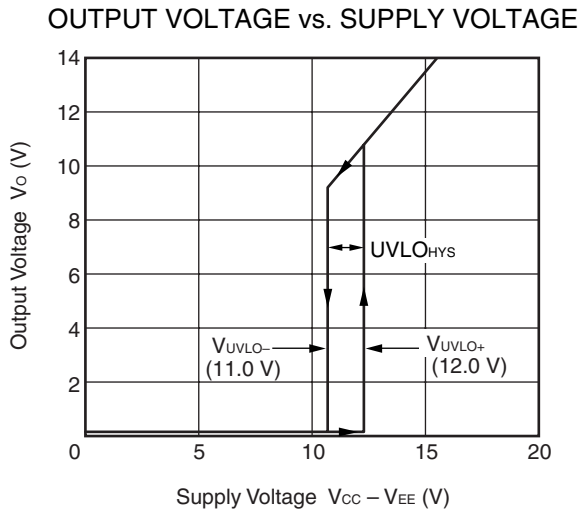

**Remark** The graph indicates nominal characteristics.

<R> TAPING SPECIFICATIONS (UNIT: mm)

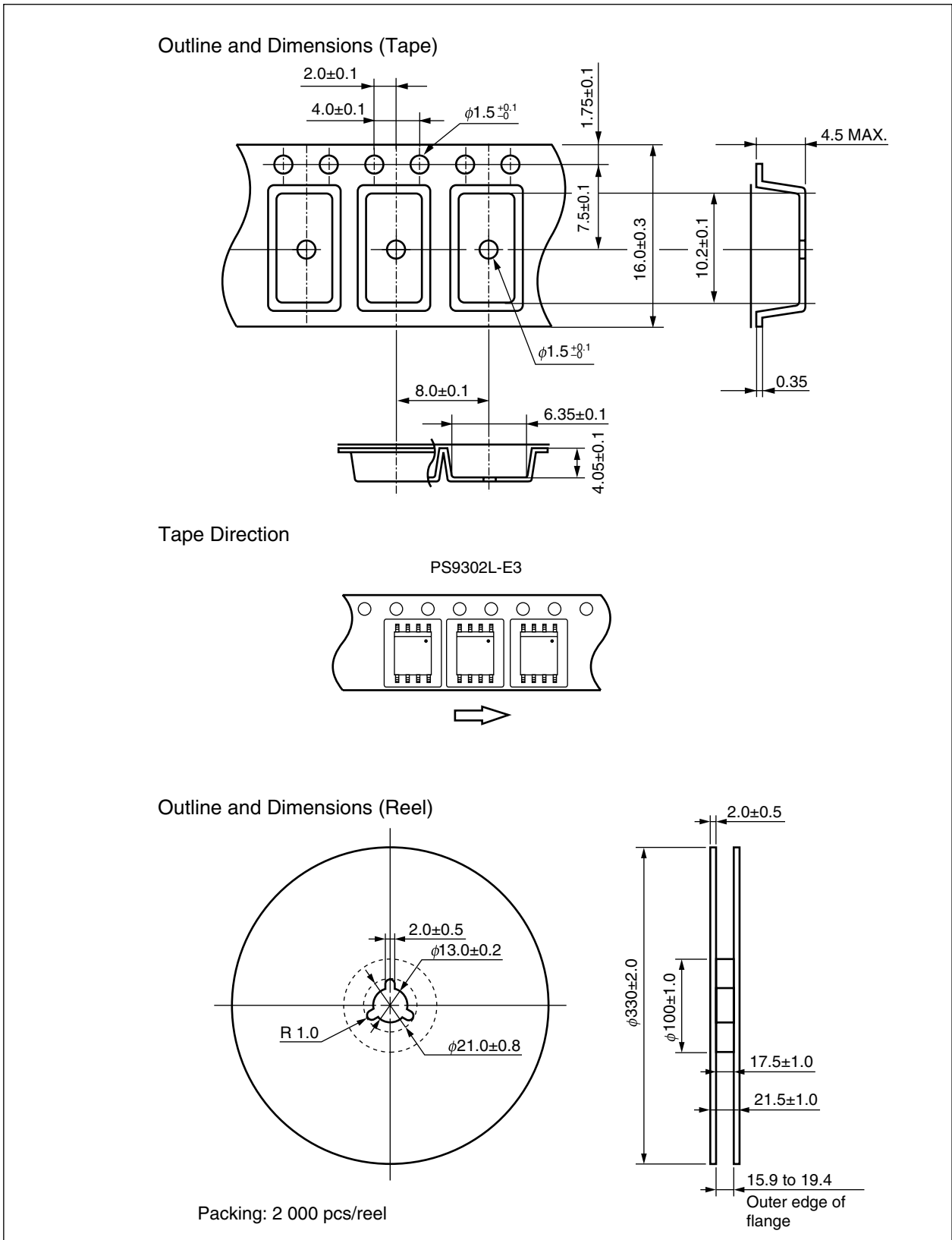

<R> RECOMMENDED MOUNT PAD DIMENSIONS (UNIT: mm)

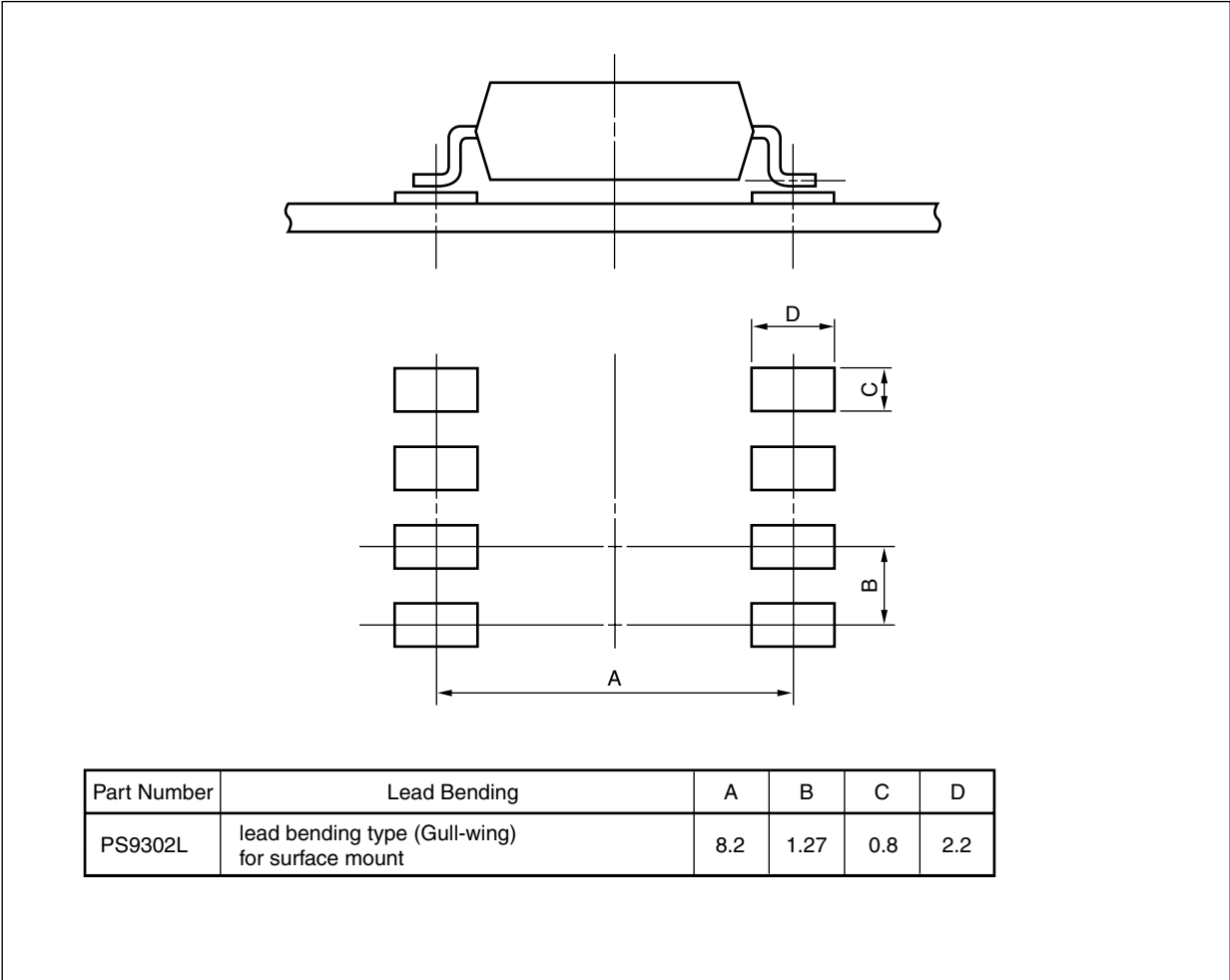

<R> NOTES ON HANDLING

1. Recommended soldering conditions

(1) Infrared reflow soldering

- Peak reflow temperature 260°C or below (package surface temperature)
- Time of peak reflow temperature 10 seconds or less
- Time of temperature higher than 220°C 60 seconds or less
- Time to preheat temperature from 120 to 180°C 120±30 s
- Number of reflows Three
- Flux Rosin flux containing small amount of chlorine (The flux with a maximum chlorine content of 0.2 Wt% is recommended.)

Recommended Temperature Profile of Infrared Reflow

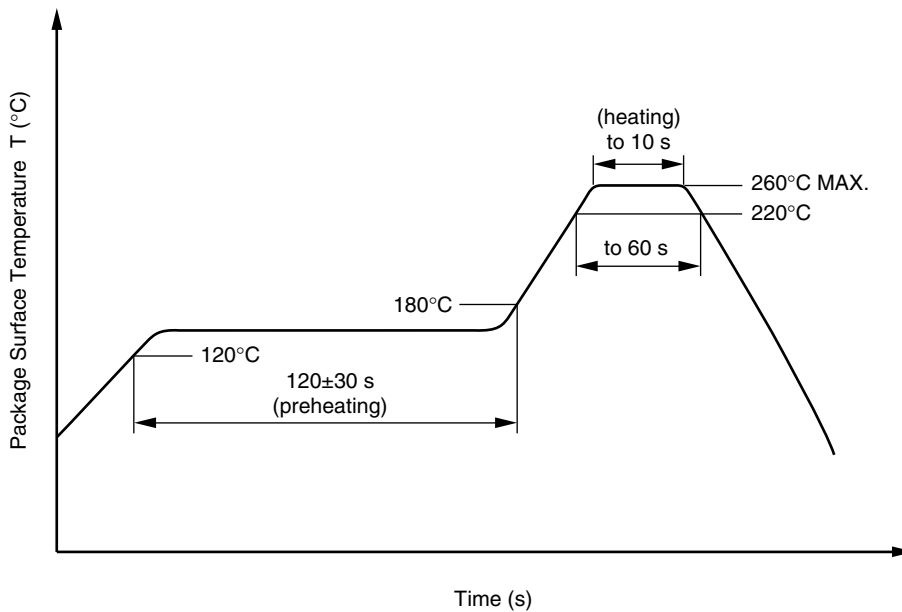

(2) Wave soldering

- Temperature 260°C or below (molten solder temperature)
- Time 10 seconds or less
- Preheating conditions 120°C or below (package surface temperature)
- Number of times One (Allowed to be dipped in solder including plastic mold portion.)
- Flux Rosin flux containing small amount of chlorine (The flux with a maximum chlorine content of 0.2 Wt% is recommended.)

(3) Soldering by soldering iron

- Peak temperature (lead part temperature) 350°C or below
- Time (each pins) 3 seconds or less
- Flux Rosin flux containing small amount of chlorine (The flux with a maximum chlorine content of 0.2 Wt% is recommended.)

- (a) Soldering of leads should be made at the point 1.5 to 2.0 mm from the root of the lead.
- (b) Please be sure that the temperature of the package would not be heated over 100°C.

**(4) Cautions**

## • Fluxes

Avoid removing the residual flux with freon-based and chlorine-based cleaning solvent.

**2. Cautions regarding noise**

Be aware that when voltage is applied suddenly between the photocoupler's input and output at startup, the output transistor may enter the on state, even if the voltage is within the absolute maximum ratings.

**<R> USAGE CAUTIONS**

1. This product is weak for static electricity by designed with high-speed integrated circuit so protect against static electricity when handling.
2. Board designing
  - (1) By-pass capacitor of more than 0.1  $\mu$ F is used between Vcc and GND near device. Also, ensure that the distance between the leads of the photocoupler and capacitor is no more than 10 mm.
  - (2) In order to avoid malfunctions and characteristics degradation, IGBT collector or emitter traces should not be closed to the LED input.
  - (3) Pin 4 (which is an NC<sup>\*1</sup> pin) can either be connected directly to the GND pin on the LED side or left open.  
Unconnected pins should not be used as a bypass for signals or for any other similar purpose because this may degrade the internal noise environment of the device.  
**\*1** NC: Non-Connection (No Connection)
3. Make sure the rise/fall time of the forward current is 0.5  $\mu$ s or less.
4. In order to avoid malfunctions, make sure the rise/fall slope of the supply voltage is 3 V/ $\mu$ s or less.
5. Avoid storage at a high temperature and high humidity.



<R> SPECIFICATION OF VDE MARKS LICENSE DOCUMENT

Parameter	Symbol	Spec.	Unit
Climatic test class (IEC 60068-1/DIN EN 60068-1)		55/100/21	
Dielectric strength maximum operating isolation voltage Test voltage (partial discharge test, procedure a for type test and random test) $U_{pr} = 1.5 \times U_{IORM}, P_d < 5 \text{ pC}$	$U_{IORM}$ $U_{pr}$	1 130 1 695	$V_{peak}$ $V_{peak}$
Test voltage (partial discharge test, procedure b for all devices) $U_{pr} = 1.875 \times U_{IORM}, P_d < 5 \text{ pC}$	$U_{pr}$	2 119	$V_{peak}$
Highest permissible overvoltage	$U_{TR}$	8 000	$V_{peak}$
Degree of pollution (DIN EN 60664-1 VDE0110 Part 1)		2	
Comparative tracking index (IEC 60112/DIN EN 60112 (VDE 0303 Part 11))	CTI	175	
Material group (DIN EN 60664-1 VDE0110 Part 1)		III a	
Storage temperature range	$T_{stg}$	-55 to +125	°C
Operating temperature range	$T_A$	-40 to +100	°C
Isolation resistance, minimum value $V_{IO} = 500 \text{ V dc at } T_A = 25^\circ\text{C}$ $V_{IO} = 500 \text{ V dc at } T_A \text{ MAX. at least } 100^\circ\text{C}$	$R_{is \text{ MIN.}}$ $R_{is \text{ MIN.}}$	$10^{12}$ $10^{11}$	$\Omega$ $\Omega$
Safety maximum ratings (maximum permissible in case of fault, see thermal derating curve) Package temperature Current (input current $I_F$ , $P_{si} = 0$ ) Power (output or total power dissipation) Isolation resistance $V_{IO} = 500 \text{ V dc at } T_A = T_{si}$	$T_{si}$ $I_{si}$ $P_{si}$ $R_{is \text{ MIN.}}$	175 400 700 $10^9$	°C mA mW $\Omega$

- **The information in this document is current as of August, 2009. The information is subject to change without notice. For actual design-in, refer to the latest publications of NEC Electronics data sheets, etc., for the most up-to-date specifications of NEC Electronics products. Not all products and/or types are available in every country. Please check with an NEC Electronics sales representative for availability and additional information.**
- No part of this document may be copied or reproduced in any form or by any means without the prior written consent of NEC Electronics. NEC Electronics assumes no responsibility for any errors that may appear in this document.
- NEC Electronics does not assume any liability for infringement of patents, copyrights or other intellectual property rights of third parties by or arising from the use of NEC Electronics products listed in this document or any other liability arising from the use of such products. No license, express, implied or otherwise, is granted under any patents, copyrights or other intellectual property rights of NEC Electronics or others.
- Descriptions of circuits, software and other related information in this document are provided for illustrative purposes in semiconductor product operation and application examples. The incorporation of these circuits, software and information in the design of a customer's equipment shall be done under the full responsibility of the customer. NEC Electronics assumes no responsibility for any losses incurred by customers or third parties arising from the use of these circuits, software and information.
- While NEC Electronics endeavors to enhance the quality and safety of NEC Electronics products, customers agree and acknowledge that the possibility of defects thereof cannot be eliminated entirely. In addition, NEC Electronics products are not taken measures to prevent radioactive rays in the product design. When customers use NEC Electronics products with their products, customers shall, on their own responsibility, incorporate sufficient safety measures such as redundancy, fire-containment and anti-failure features to their products in order to avoid risks of the damages to property (including public or social property) or injury (including death) to persons, as the result of defects of NEC Electronics products.
- NEC Electronics products are classified into the following three quality grades: "Standard", "Special" and "Specific".  
 The "Specific" quality grade applies only to NEC Electronics products developed based on a customer-designated "quality assurance program" for a specific application. The recommended applications of an NEC Electronics product depend on its quality grade, as indicated below. Customers must check the quality grade of each NEC Electronics product before using it in a particular application.  
 "Standard": Computers, office equipment, communications equipment, test and measurement equipment, audio and visual equipment, home electronic appliances, machine tools, personal electronic equipment and industrial robots.  
 "Special": Transportation equipment (automobiles, trains, ships, etc.), traffic control systems, anti-disaster systems, anti-crime systems, safety equipment and medical equipment (not specifically designed for life support).  
 "Specific": Aircraft, aerospace equipment, submersible repeaters, nuclear reactor control systems, life support systems and medical equipment for life support, etc.

The quality grade of NEC Electronics products is "Standard" unless otherwise expressly specified in NEC Electronics data sheets or data books, etc. If customers wish to use NEC Electronics products in applications not intended by NEC Electronics, they must contact an NEC Electronics sales representative in advance to determine NEC Electronics' willingness to support a given application.

(Note)

- (1) "NEC Electronics" as used in this statement means NEC Electronics Corporation and also includes its majority-owned subsidiaries.
- (2) "NEC Electronics products" means any product developed or manufactured by or for NEC Electronics (as defined above).

M8E0904E

<p><b>Caution</b> GaAs Products</p>	<p>This product uses gallium arsenide (GaAs). GaAs vapor and powder are hazardous to human health if inhaled or ingested, so please observe the following points.</p> <ul style="list-style-type: none"> <li>• Follow related laws and ordinances when disposing of the product. If there are no applicable laws and/or ordinances, dispose of the product as recommended below.               <ol style="list-style-type: none"> <li>1. Commission a disposal company able to (with a license to) collect, transport and dispose of materials that contain arsenic and other such industrial waste materials.</li> <li>2. Exclude the product from general industrial waste and household garbage, and ensure that the product is controlled (as industrial waste subject to special control) up until final disposal.</li> </ol> </li> <li>• Do not burn, destroy, cut, crush, or chemically dissolve the product.</li> <li>• Do not lick the product or in any way allow it to enter the mouth.</li> </ul>
-------------------------------------	---