

1. PART NO. EXPRESSION :

SSB1003101MZ F

(a) (b) (c) (d)(e)(f)

(a) Series code

(b) Dimension code

(c) Inductance code : 101 = 100uH

(d) Tolerance code : M = ±20%

(e) X, Y, Z : Standard part

(f) F : Lead Free

2. CONFIGURATION & DIMENSIONS :

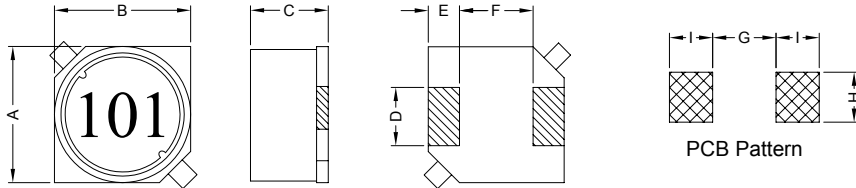

Unit:m/m

A	B	C	D	E	F	G	H	I
10.0±0.3	10.0±0.3	3.0±0.3	2.4±0.2	2.0±0.2	6.0±0.2	5.7 Ref.	2.8 Ref.	2.5 Ref.

3. SCHEMATIC :

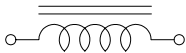

4. MATERIALS :

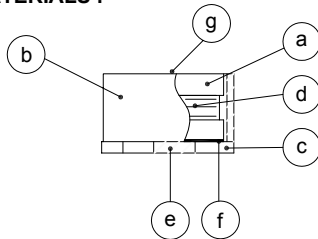

(a) Core : DR Ferrite Core

(b) Core : RI Ferrite Core

(c) Base : LCP

(d) Wire : Enamelled Copper Wire

(e) Terminal : Tinned Copper Plate

(f) Adhesive : Epoxy

(g) Ink : Bon Margue

5. GENERAL SPECIFICATION :

- a) Temp. rise : 40°C Max.
- b) Rated current : Base on temp. rise & $\Delta L/L0A = 30\%$ Max.
- c) Storage temp. : -40°C to +125°C
- d) Operating temp. : -40°C to +85°C
- e) Resistance to solder heat : 260°C.10 secs



RoHS Compliant

NOTE : Specifications subject to change without notice. Please check our website for latest information.

18.04.2008



SUPERWORLD ELECTRONICS (S) PTE LTD

6. ELECTRICAL CHARACTERISTICS :

Part No.	Inductance (μ H)	Test Frequency (Hz)	RDC ($m\Omega$) Max.	IDC (A) Max.
SSB10031R5MF	1.5 \pm 20%	1V / 100K	22	4.00
SSB10032R2MF	2.2 \pm 20%	1V / 100K	25	3.50
SSB10033R3MF	3.3 \pm 20%	1V / 100K	40	3.00
SSB10034R7MF	4.7 \pm 20%	1V / 100K	45	2.50
SSB10036R8MF	6.8 \pm 20%	1V / 100K	60	2.20
SSB1003100MF	10.0 \pm 20%	1V / 100K	70	2.00
SSB1003120MF	12.0 \pm 20%	1V / 100K	95	1.90
SSB1003150MF	15.0 \pm 20%	1V / 100K	120	1.70
SSB1003180MF	18.0 \pm 20%	1V / 100K	130	1.55
SSB1003220MF	22.0 \pm 20%	1V / 100K	180	1.45
SSB1003270MF	27.0 \pm 20%	1V / 100K	200	1.30
SSB1003330MF	33.0 \pm 20%	1V / 100K	210	1.10
SSB1003390MF	39.0 \pm 20%	1V / 100K	270	1.00
SSB1003470MF	47.0 \pm 20%	1V / 100K	300	0.85
SSB1003560MF	56.0 \pm 20%	1V / 100K	400	0.80
SSB1003680MF	68.0 \pm 20%	1V / 100K	440	0.75
SSB1003820MF	82.0 \pm 20%	1V / 100K	490	0.65
SSB1003101MF	100.0 \pm 20%	1V / 100K	670	0.60
SSB1003121MF	120.0 \pm 20%	1V / 100K	740	0.55
SSB1003151MF	150.0 \pm 20%	1V / 100K	790	0.50
SSB1003181MF	180.0 \pm 20%	1V / 100K	1200	0.45
SSB1003221MF	220.0 \pm 20%	1V / 100K	1350	0.40
SSB1003271MF	270.0 \pm 20%	1V / 100K	1800	0.38
SSB1003-331MF	330.0 \pm 20%	1V / 100K	2000	0.32
SSB1003-391MF	390.0 \pm 20%	1V / 100K	2100	0.30
SSB1003-471MF	470.0 \pm 20%	1V / 100K	3500	0.28
SSB1003-561MF	560.0 \pm 20%	1V / 100K	3900	0.25
SSB1003-681MF	680.0 \pm 20%	1V / 100K	4100	0.22
SSB1003-821MF	820.0 \pm 20%	1V / 100K	4550	0.20
SSB1003-102MF	1000.0 \pm 20%	1V / 100K	5100	0.18



RoHS Compliant

NOTE : Specifications subject to change without notice. Please check our website for latest information.

18.04.2008



SUPERWORLD ELECTRONICS (S) PTE LTD

PG. 2

7. CHARACTERISTICS CURVES :

@ TEMP. RISE VS. DC SUPERPOSITION RESPONSE CURVE

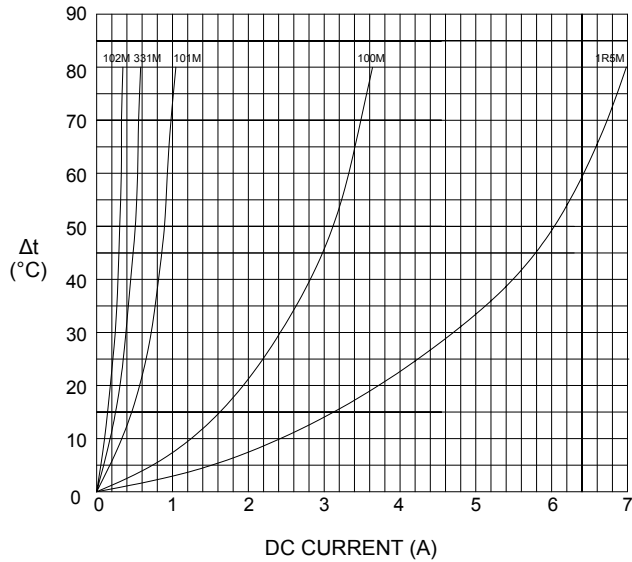

@ INDUCTANCE VS. FREQUENCY RESPONSE CURVE

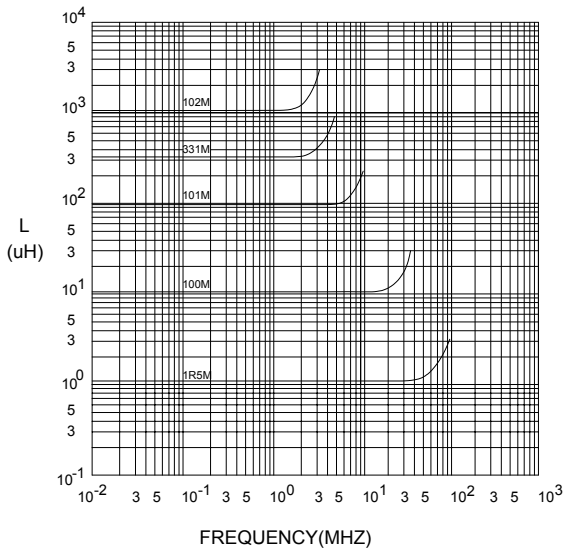

@ INDUCTANCE VS. DC SUPERPOSITION RESPONSE CURVE

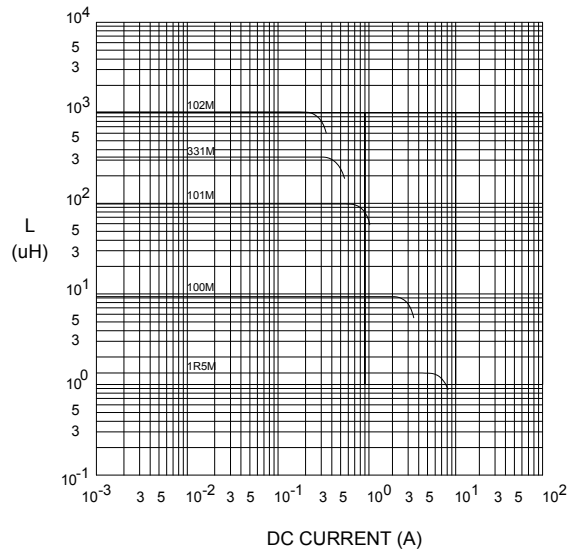

RoHS Compliant

NOTE : Specifications subject to change without notice. Please check our website for latest information.

18.04.2008



SUPERWORLD ELECTRONICS (S) PTE LTD

RECOMMENDED SOLDERING CONDITIONS REFLOW SOLDERINGS

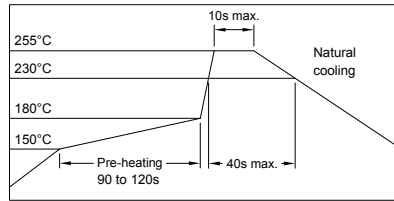

8. PACKAGING INFORMATION :

(1) CONFIGURATION

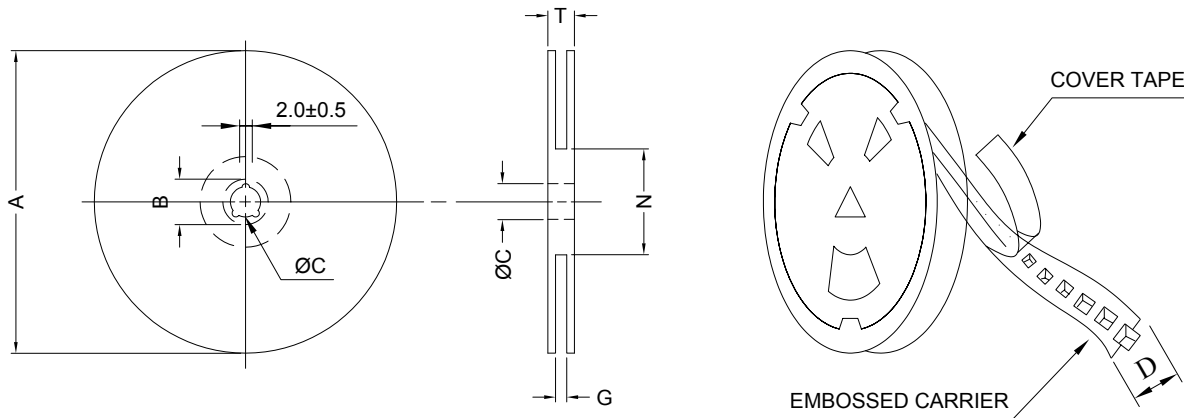

* CARRIER TAPE WIDTH : D

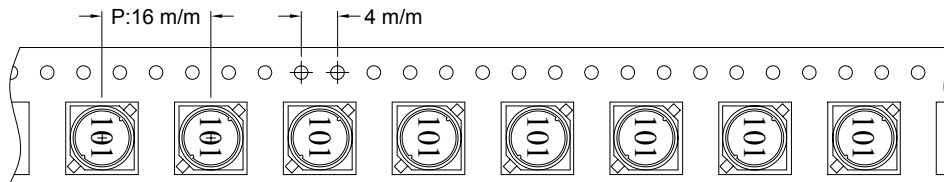

(2) DIMENSIONS

Unit:m/m

STYLE	A	B	C	D	G	N	T
13-24	330	21±0.8	13	24	26 ⁺⁰	50 ⁻⁰	30.4

(3) Q'TY & G.W. PER PACKAGE

SERIES	INNER : REEL			OUTER : CARTON		
	Q'TY (PCS)	G.W. (gw)	STYLE	Q'TY (PCS)	G.W. (Kg)	SIZE (cm)
SSB1003	1000	1000	13-24	4000	7.5	40 x 40 x 24



RoHS Compliant

NOTE : Specifications subject to change without notice. Please check our website for latest information.

18.04.2008



SUPERWORLD ELECTRONICS (S) PTE LTD

9. RELIABILITY AND TEST CONDITION :

TEST ITEM	SPECIFICATION	TEST CONDITION
SOLDERABILITY	MORE THAN 90% OF THE TERMINAL ELECTRODE SHALL BE COVERED WITH FRESH SOLDER.	PREHEAT : 125±25°C FOR 60 SECONDS SOLDER : 99%Sn/0.3%Ag/0.7%Cu or equivalent SOLDER TEMP. : 245±5°C FLUX : ROSIN DIP TIME : 4±1 SECONDS
THERMAL SHOCK TEST (TEMP. CYCLE)	INDUCTANCE SHALL NOT CHANGE MORE THAN ±20%	ROOM TEMP. → -25±2°C 15 MINUTES → 30 MINUTES ROOM TEMP. → 85±2°C 15 MINUTES → 30 MINUTES TOTAL : 50 CYCLES
HUMIDITY RESISTANCE TEST		TEMPERATURE : 40±2°C HUMIDITY : 90 ~ 95% APPLIED CURRENT : PER SPEC. TIME : 500 HOURS
HIGH TEMP. RESISTANCE TEST		TEMPERATURE : 85±2°C APPLIED CURRENT : PER SPEC. TIME : 500 HOURS



RoHS Compliant

NOTE : Specifications subject to change without notice. Please check our website for latest information.

18.04.2008



SUPERWORLD ELECTRONICS (S) PTE LTD

PG. 5

10. UL CARD :

OBMW2 **November 30, 2000**
Magnet Wire - Component
PACIFIC ELECTRIC WIRE & CABLE (SHENZHEN) CO LTD **E201757**
607 BAOLONG INDUSTRIAL ESTATE LONGGANG, SHENZHEN
GUANGDONG CHINA

Mtl Dsg	BC	Coating Type	TC	ANSI Type	TI
UEW/U		Polyurethane	—	—	130
PEW/U		Polyester	—	MW5-C	155°C
PEWH/U		Modified Polyester	—	MW30-C	180
PEW-NY/U		Polyester	Polyamide	MW24-C	155
HAI/U		Polyester(Amide)(Imide)	Polyamideimide	MW35,73	200
UEW-NY/U		Polyurethane	Polyamide	MW80-C	155
				MW28-C	130

Marking: Company name and material designation or marked designation on package or reel, and Recognized Component Mark.

See General Information Preceding These Recognitions

1/3/2001 **Underwriters Laboratories Inc.** **Card 1 of 2**

SUMITOMO CHEMICAL CO LTD **E54705 (M)**
5-33 KITAHAMA 4-CHOME CHUO-KO, OSAKA JAPAN

Mtl Dsg	Col	Min Thk mm	UL94 Flame Class	Elec	RTI		w/o Imp	H W I	H A I	H V R	D 4 5	C T I
					with Imp	Mech						
Liquid crystal polyester (LCP), designated "EKONOL" or "SUMIKASUPER", furnished in the form of pellets, (Contd)												
E4008, E400X	NC, BK	0.30	94V-0	130	130	130	—	—	—	—	—	—
		0.75	94V-0	130	130	130	3	4	—	—	—	—
		1.5	94V-0	130	130	130	2	4	—	—	—	—
		3.0	94V-0	130	130	130	1	4	0	5	4	—
E4008	NC, WT, BK	0.30	94V-0	130	130	130	—	—	—	—	—	—
		0.75	94V-0	220	180	220	3	4	—	—	—	—
		1.5	94V-0	220	200	240	2	4	—	—	—	—
		3.0	94V-0	220	200	240	1	4	0	5	4	—
E4010	NC, BK	0.30	94V-0	130	130	130	—	—	—	—	—	—
		0.75	94V-0	220	180	220	3	4	—	—	—	—
		1.5	94V-0	220	200	240	2	4	—	—	—	—
		3.0	94V-0	220	200	240	1	4	0	5	4	—
E400(Y)L, E4008L	NC, BK	0.30	94V-0	130	130	130	—	—	—	—	—	—
		0.75	94V-0	130	130	130	3	4	—	—	—	—
		1.5	94V-0	130	130	130	2	4	—	—	—	—
		3.0	94V-0	130	130	130	1	4	0	5	4	—
E4810	NC, BK	0.30	94V-0	130	130	130	—	—	—	—	—	—
		0.75	94V-0	130	130	130	0	4	—	—	—	—
		1.5	94V-0	130	130	130	0	4	—	—	—	—
		3.0	94V-0	130	130	130	1	4	0	5	4	—

(X) Denotes any number 1 thru 9.
(Y) Denotes any number 1 thru 7.



RoHS Compliant

NOTE : Specifications subject to change without notice. Please check our website for latest information.

18.04.2008



SUPERWORLD ELECTRONICS (S) PTE LTD