

PART NUMBER: MES20

DESCRIPTION: incremental encoder

ELECTRICAL SPECIFICATIONS

output waveform	Square wave
output signals	A, B, Z phase
current consumption	≤50 mA
frequency response	0~100 KHz
output phase difference	A, B phase difference 90° ± 45° (T/4±T/8) Z phase T±T/2 (see output waveform)
supply voltage	5 V ~ 12 V dc ± 10%, 24 V dc ± 10% (open collector output only)
output resolution (ppr)	40, 50, 60, 100, 200, 250, 256, 300, 360, 400, 500, 512, 600, 800, 1000, 1024, 1200, 1800, 2000, 2048, 2500, 3600
waveform rise/fall time	2μ or less (outout cable 1m or less)

MECHANICAL SPECIFICATIONS

max shaft load, radial:	19.6N (2kgf)	14.7N (1.5kgf) (600-3600 ppr)
axial:	9.8N (1kgf)	4.9N (0.5kgf) (600-3600 ppr)
starting torque	2 x 10 ⁻³ NM (20 gf-cm)	
max rotational speed	6000 RPM	
shock resistance	500 m/s ² (50G), 3 times each on XYZ	
vibration proof	55 Hz, double amplitude 1.5mm, 2 hours each on XYZ	
weight	70g (with 1m cable)	
cable	4.2mm outside diameter, 5 core vinyl wire insulated shield cable (1m)	

ENVIRONMENTAL SPECIFICATIONS

operating temp	-10° to +70° C
storage temp	-20° to +80° C
humidity	RH 35%~90% non collecting

ORDERING INSTRUCTIONS

MES20 - XXXXPXX

Resolution (PPR):

40 = 40 PPR	600 = 600 PPR
60 = 60 PPR	800 = 600 PPR
100 = 100 PPR	1000 = 1000 PPR
200 = 200 PPR	1024 = 1024 PPR
250 = 250 PPR	1200 = 1200 PPR
256 = 256 PPR	1800 = 1800 PPR
300 = 300 PPR	2000 = 2000 PPR
360 = 360 PPR	2048 = 2048 PPR
400 = 400 PPR	1800 = 1800 PPR
500 = 500 PPR	2500 = 2500 PPR
512 = 512 PPR	3600 = 3600 PPR

Output Circuit:
" " = Voltage output
C = Open collector output
E = Line Driver

Input Voltage:
1 = 5V dc ± 10%
2 = 12V dc ± 10%
3 = 5 ~ 12V dc ± 10%
4 = 24V dc ± 10%

PART NUMBER: MES20

DESCRIPTION: incremental encoder

CIRCUIT CONNECTIONS

Voltage Output

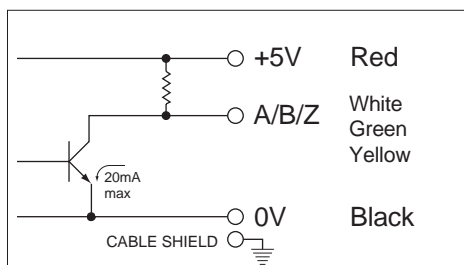

Open Collector Output (C)

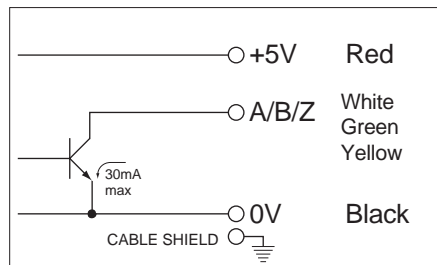

Line Drive Output (E)

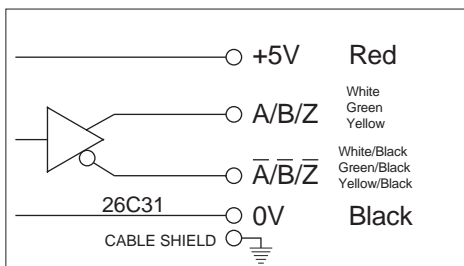

OUTPUT WAVEFORM

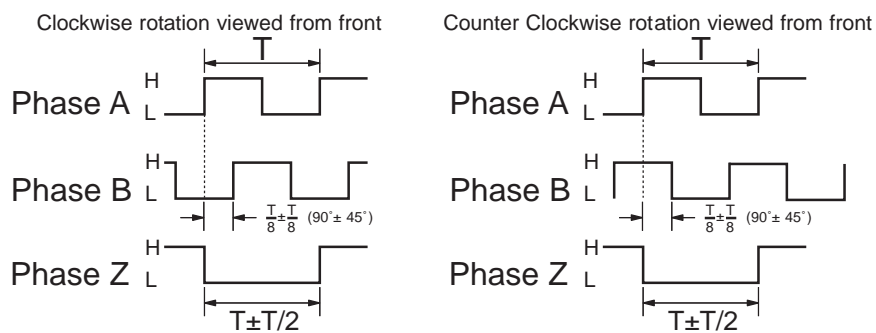

The position of Z phase against A, B phase is not specified

REV.	DESCRIPTION	DATE
A	NEW DRAWING	7/27/2007

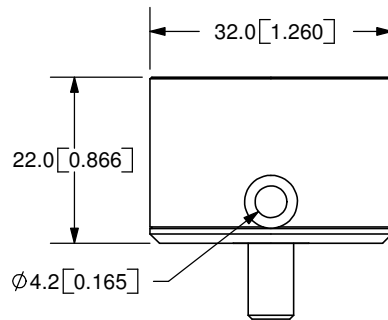
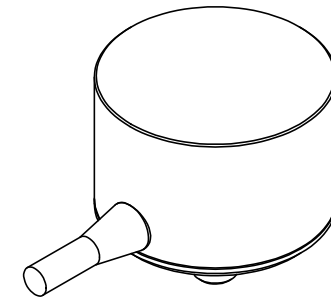
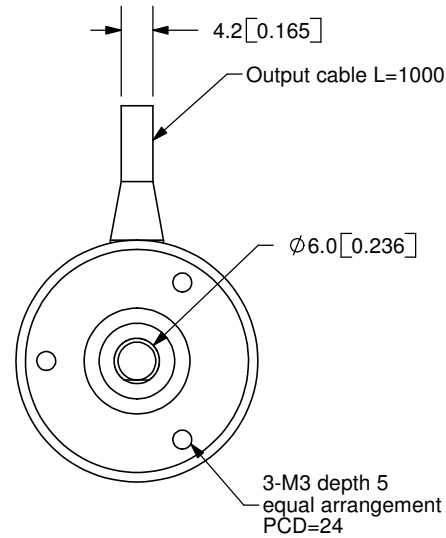
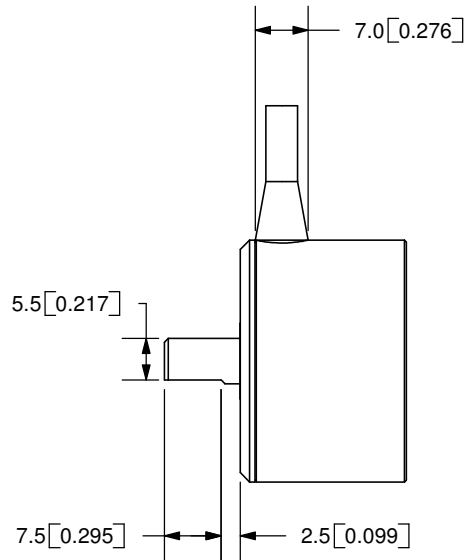

TOLERANCE:
±0.3mm UNLESS OTHERWISE
SPECIFIED



20050 SW 112th Ave.
Tualatin, OR 97062
Phone: 503-612-2300
800-275-4899
Fax: 503-612-2383
Website: www.cui.com

TITLE: Incremental Encoder		REV: A
PART NO. MES20		UNITS: MM [INCHES]
DRAWN BY: JMS	APPROVED BY:	SCALE: 1:1

PC FILE NAME:
MES20

COPYRIGHT 2007
BY CUI INC.

Cable Color	Red	White	Green	Yellow	Black	-	-	-
Output Type	Power	A-Phase	B-Phase	Z-Phase	0V	-	-	-