

Silicon PNP Power Transistors

BD240/A/B/C

DESCRIPTION

- With TO-220C package
- Complement to type BD239/A/B/C

APPLICATIONS

- For medium power linear and switching applications

PINNING

PIN	DESCRIPTION
1	Emitter
2	Collector;connected to mounting base
3	Base

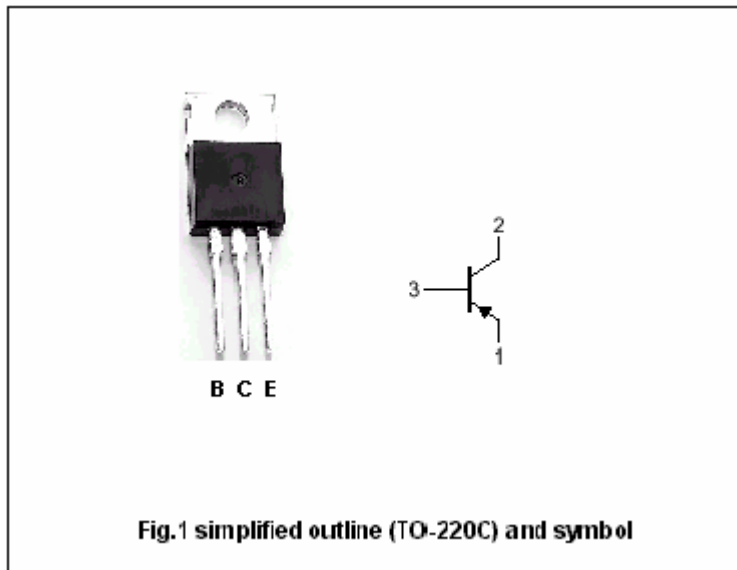

Absolute maximum ratings (Ta=25°C)

SYMBOL	PARAMETER	CONDITIONS	VALUE	UNIT
V _{CBO}	Collector-base voltage	BD240	-55	V
		BD240A	-70	
		BD240B	-90	
		BD240C	-115	
V _{CEO}	Collector-emitter voltage	BD240	-45	V
		BD240A	-60	
		BD240B	-80	
		BD240C	-100	
V _{EBO}	Emitter-base voltage	Open collector	-5	V
I _C	Collector current		-2	A
I _{CM}	Collector current-peak		-4	A
I _B	Base current		-0.6	A
P _C	Collector power dissipation	T _C =25°C	30	W
T _j	Junction temperature		150	°C
T _{stg}	Storage temperature		-65~150	°C

Silicon PNP Power Transistors

BD240/A/B/C

CHARACTERISTICS

T_j=25°C unless otherwise specified

SYMBOL	PARAMETER	CONDITIONS	MIN	TYP.	MAX	UNIT	
V _{CEO(SUS)}	Collector-emitter sustaining voltage	BD240	-45			V	
		BD240A	-60				
		BD240B	-80				
		BD240C	-100				
V _{CEsat}	Collector-emitter saturation voltage	I _C =-1 A; I _B =-0.2 A			-0.7	V	
V _{BE}	Base-emitter on voltage	I _C =-1 A; V _{CE} =-4V			-1.3	V	
I _{CEO}	Collector cut-off current	BD240/A	V _{CE} =-30V; I _B =0			-0.3	mA
		BD240B/C	V _{CE} =-60V; I _B =0				
I _{CES}	Collector cut-off current	BD240	V _{CE} =-45V; V _{BE} =0			-0.2	mA
		BD240A	V _{CE} =-60V; V _{BE} =0				
		BD240B	V _{CE} =-80V; V _{BE} =0				
		BD240C	V _{CE} =-100V; V _{BE} =0				
I _{EBO}	Emitter cut-off current	V _{EB} =-5V; I _C =0			-1	mA	
h _{FE-1}	DC current gain	I _C =-0.2A; V _{CE} =-4V	40				
h _{FE-2}	DC current gain	I _C =-1A; V _{CE} =-4V	15				

Silicon PNP Power Transistors

BD240/A/B/C

PACKAGE OUTLINE

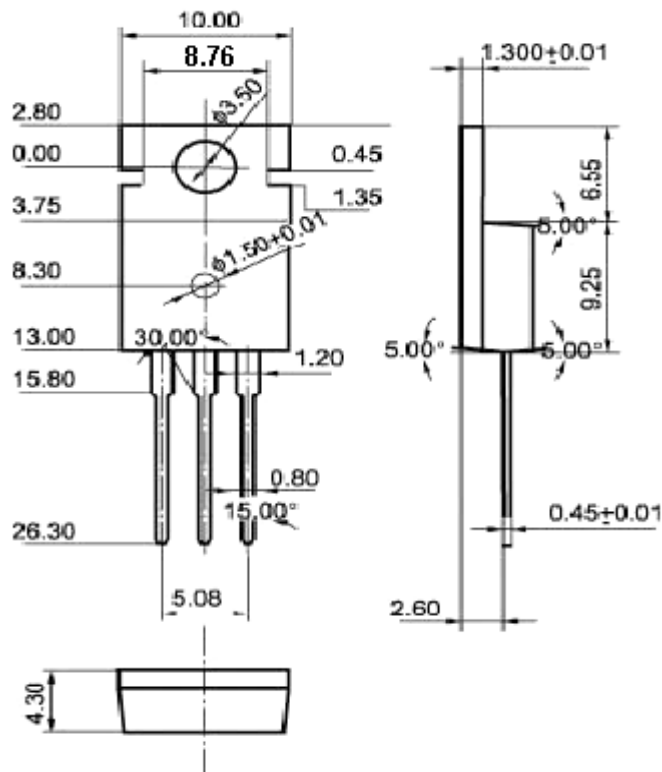

Fig.2 Outline dimensions (unindicated tolerance:±0.10 mm)