

Silicon NPN Power Transistors

2SC1501

DESCRIPTION

- With TO-126 package
- High breakdown voltage
- Large power dissipation

APPLICATIONS

- For medium power amplifier applications

PINNING

PIN	DESCRIPTION
1	Emitter
2	Collector
3	Base

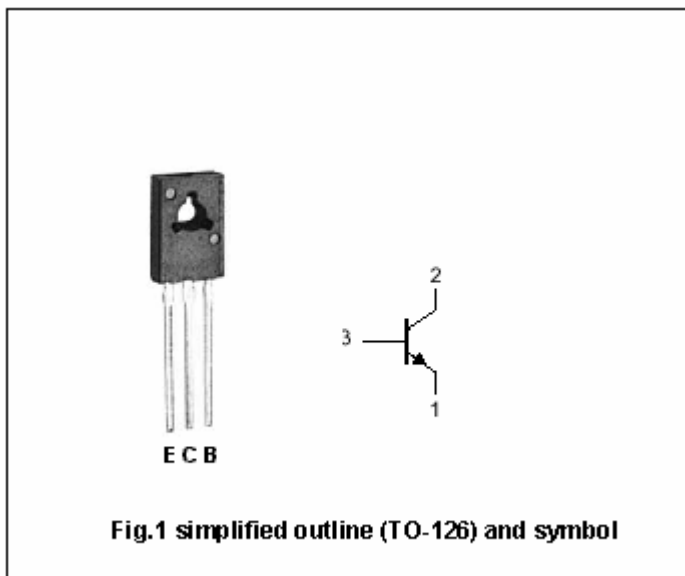

Absolute maximum ratings (Ta=25°C)

SYMBOL	PARAMETER	CONDITIONS	VALUE	UNIT
V <sub>CBO</sub>	Collector-base voltage	Open emitter	300	V
V <sub>CEO</sub>	Collector-emitter voltage	Open base	300	V
V <sub>EBO</sub>	Emitter-base voltage	Open collector	5	V
I <sub>C</sub>	Collector current		0.1	A
I <sub>CM</sub>	Collector current-peak		0.15	A
P <sub>C</sub>	Collector power dissipation	T <sub>C</sub> =25°C	10	W
T <sub>j</sub>	Junction temperature		150	°C
T <sub>stg</sub>	Storage temperature		-55~150	°C

## Silicon NPN Power Transistors

## 2SC1501

## CHARACTERISTICS

T<sub>j</sub>=25°C unless otherwise specified

SYMBOL	PARAMETER	CONDITIONS	MIN	TYP.	MAX	UNIT
V <sub>(BR)CBO</sub>	Collector-base breakdown voltage	I <sub>C</sub> =100μA; I <sub>E</sub> =0	300			V
V <sub>(BR)CEO</sub>	Collector-emitter breakdown voltage	I <sub>C</sub> =1mA; I <sub>B</sub> =0	300			V
V <sub>(BR)EBO</sub>	Emitter-base breakdown voltage	I <sub>E</sub> =100μA; I <sub>C</sub> =0	5			V
V <sub>CEsat</sub>	Collector-emitter saturation voltage	I <sub>C</sub> =100mA I <sub>B</sub> =10mA			5.0	V
V <sub>BE</sub>	Base-emitter on voltage	I <sub>C</sub> =50mA; V <sub>CE</sub> =10V			1.2	V
h <sub>FE-1</sub>	DC current gain	I <sub>C</sub> =10mA; V <sub>CE</sub> =10V	30			
h <sub>FE-2</sub>	DC current gain	I <sub>C</sub> =50mA; V <sub>CE</sub> =10V	30		200	
I <sub>CBO</sub>	Collector cut-off current	V <sub>CB</sub> =300V; I <sub>E</sub> =0			100	μA
C <sub>OB</sub>	Output capacitance	I <sub>E</sub> =0; V <sub>CB</sub> =30V; f=1MHz		8		pF
f <sub>T</sub>	Transition frequency	I <sub>E</sub> =20mA; V <sub>CB</sub> =30V		55		MHz

◆ h<sub>FE-2</sub> classifications

P	Q	R	S
30-60	50-100	80-150	100-200

Silicon NPN Power Transistors

2SC1501

PACKAGE OUTLINE

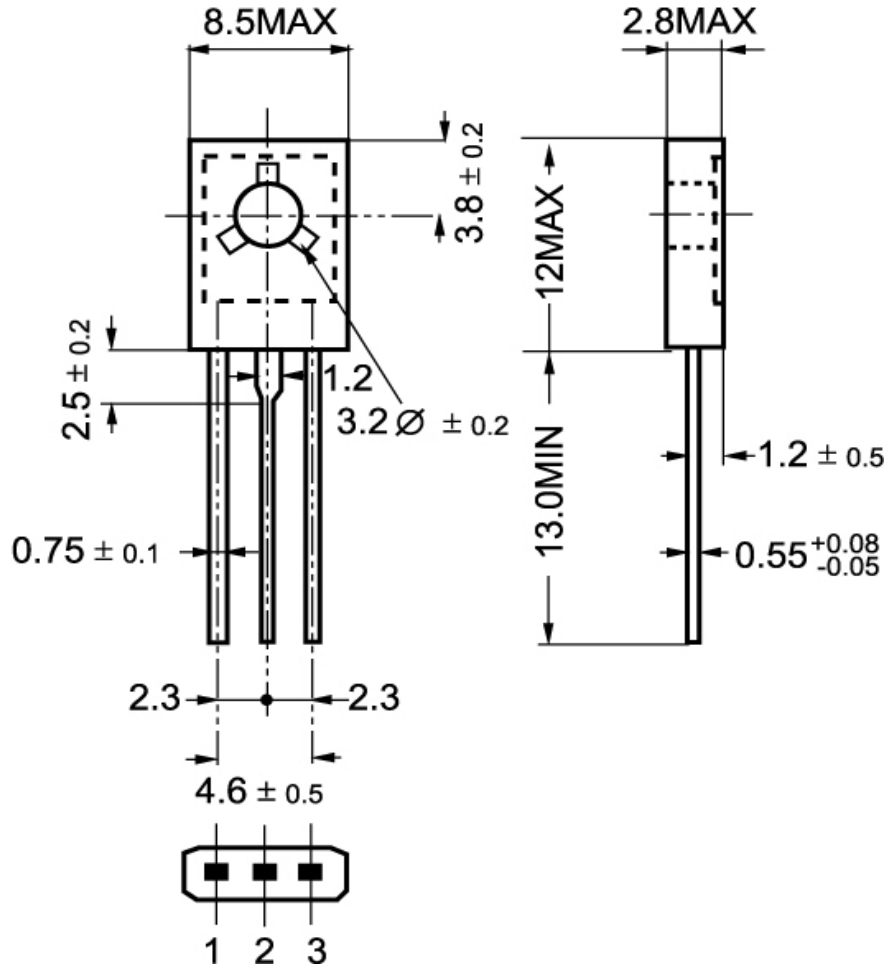

Fig.2 outline dimensions