

isc Silicon PNP Power Transistor

MJE2901T

DESCRIPTION

- Collector-Emitter Breakdown Voltage-  
:  $V_{(BR)CEO} = -60V(\text{Min})$
- High DC Current Gain-  
:  $h_{FE} = 25-100 @ I_C = -3A$
- Complement to Type MJE2801T

APPLICATIONS

- Designed for use as an output device in complementary audio amplifiers up to 35 watts music power per channel.

ABSOLUTE MAXIMUM RATINGS( $T_a=25^\circ\text{C}$ )

SYMBOL	PARAMETER	VALUE	UNIT
$V_{CBO}$	Collector-Base Voltage	-60	V
$V_{CEO}$	Collector-Emitter Voltage	-60	V
$V_{EBO}$	Emitter-Base Voltage	-4	V
$I_C$	Collector Current-Continuous	-10	A
$I_B$	Base Current-Continuous	-5	A
$P_C$	Collector Power Dissipation @ $T_C=25^\circ\text{C}$	75	W
$T_J$	Junction Temperature	150	$^\circ\text{C}$
$T_{stg}$	Storage Temperature Range	-55~150	$^\circ\text{C}$

THERMAL CHARACTERISTICS

SYMBOL	PARAMETER	MAX	UNIT
$R_{th\ j-c}$	Thermal Resistance, Junction to Case	1.67	$^\circ\text{C/W}$

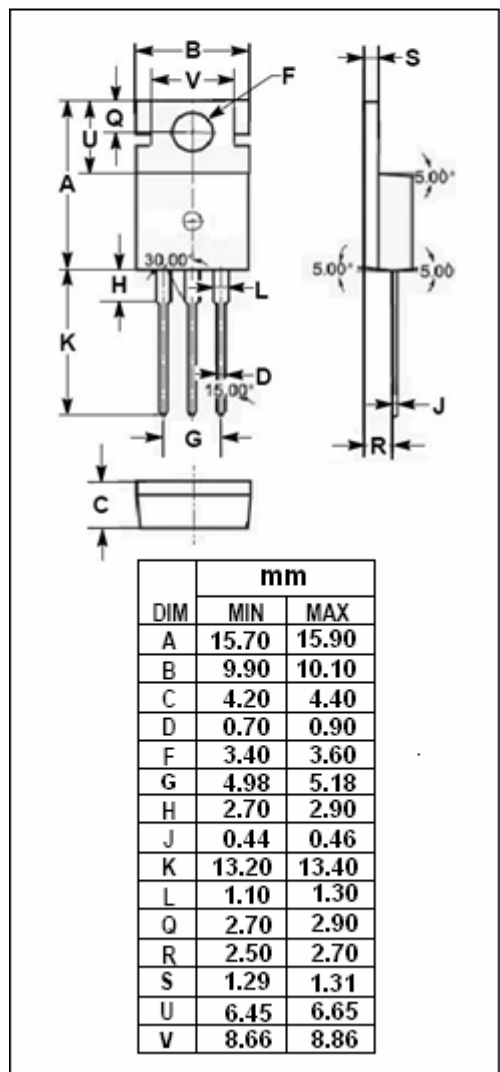
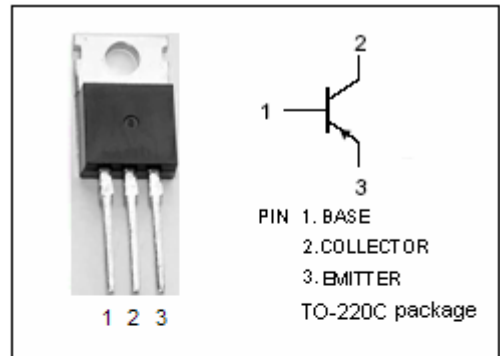

**isc Silicon PNP Power Transistor****MJE2901T****ELECTRICAL CHARACTERISTICS** $T_C=25^{\circ}\text{C}$  unless otherwise specified

SYMBOL	PARAMETER	CONDITIONS	MIN	TYP.	MAX	UNIT
$V_{(BR)CEO}$	Collector-Emitter Breakdown Voltage	$I_C = -200\text{mA}; I_B = 0$	-60			V
$V_{CE(sat)}$	Collector-Emitter Saturation Voltage	$I_C = -4\text{A}; I_B = -0.4\text{A}$			-1.1	V
$V_{BE(on)}$	Base-Emitter On Voltage	$I_C = -3\text{A}; V_{CE} = -2\text{V}$			-1.4	V
$I_{CBO}$	Collector Cutoff Current	$V_{CB} = -60\text{V}; I_E = 0$ $V_{CB} = -60\text{V}; I_E = 0; T_C = 150^{\circ}\text{C}$			-0.1 -2.0	mA
$I_{EBO}$	Emitter Cutoff Current	$V_{EB} = -4\text{V}; I_C = 0$			-1.0	mA
$h_{FE}$	DC Current Gain	$I_C = -3\text{A}; V_{CE} = -2\text{V}$	25		100	