

## FEATURES

- Wide Operating  $V_{IN}$  Range: Up to 60V
- Rugged Architecture Tolerant of 80V  $V_{IN}$  Transients
- Powerful  $1.85\Omega$  Driver Pull-Down (with 6V Supply)
- Powerful 1.1A Peak Current Driver Pull-Up (with 6V Supply)
- 7ns Fall Time Driving 1000pF Load
- 10ns Rise Time Driving 1000pF Load
- Drives Standard Threshold MOSFETs
- TTL/CMOS Compatible Inputs with Hysteresis
- Input Thresholds are Independent of Supply
- Undervoltage Lockout
- Low Profile (1mm) SOT-23 (ThinSOT™) and Thermally Enhanced 8-Pin MSOP Packages

## APPLICATIONS

- Telecommunications Power Systems
- Distributed Power Architectures
- Server Power Supplies
- High Density Power Modules
- General Purpose Low-Side Driver

 LTC and LT are registered trademarks of Linear Technology Corporation. ThinSOT is a trademark of Linear Technology Corporation. All other trademarks are the property of their respective owners. Protected by U.S. Patents including 6677210.

## DESCRIPTION

The LTC®4440-5 is a high frequency high side N-channel MOSFET gate driver that is designed to operate in applications with  $V_{IN}$  voltages up to 60V. The LTC4440-5 can also withstand and continue to function during 80V  $V_{IN}$  transients. The powerful driver capability reduces switching losses in MOSFETs with high gate capacitances. The LTC4440-5's pull-up has a peak output current of 1.1A and its pull-down has an output impedance of  $1.85\Omega$ .

The LTC4440-5 features supply independent TTL/CMOS compatible input thresholds with 350mV of hysteresis. The input logic signal is internally level-shifted to the bootstrapped supply, which may function at up to 95V above ground.

The LTC4440-5 is optimized for driving (5V) logic level FETs and contains an undervoltage lockout circuit that disables the external MOSFET when activated.

The LTC4440-5 is available in the low profile (1mm) SOT-23 or a thermally enhanced 8-lead MSOP package.

PARAMETER	LTC4440-5	LTC4440
Max Operating TS	60V	80V
Absolute Max TS	80V	100V
MOSFET Gate Drive	4V to 15V	8V to 15V
$V_{CC}$ UV <sup>+</sup>	3.2V	6.3V
$V_{CC}$ UV <sup>-</sup>	3.04V	6.0V

## TYPICAL APPLICATION

### Synchronous Phase-Modulated Full-Bridge Converter

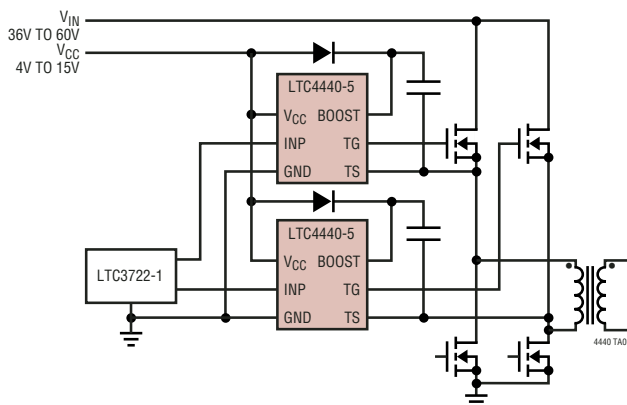

### LTC4440-5 Driving a 1000pF Capacitive Load

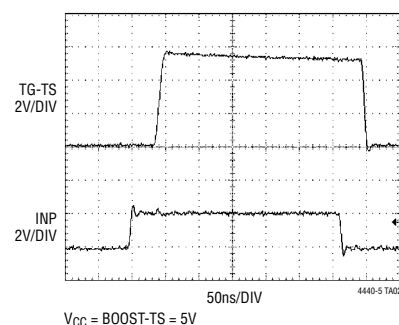

# LTC4440-5

## ABSOLUTE MAXIMUM RATINGS (Note 1)

Supply Voltage		TS Voltage (100ms).....	-5V to 80V
$V_{CC}$ .....	-0.3V to 15V	Peak Output Current < 1 $\mu$ s (TG) .....	4A
BOOST – TS .....	-0.3V to 15V	Operating Ambient Temperature Range	
INP Voltage .....	-0.3V to 15V	(Note 2) .....	-40°C to 85°C
BOOST Voltage (Continuous) .....	-0.3V to 85V	Junction Temperature (Note 3) .....	125°C
BOOST Voltage (100ms) .....	-0.3V to 95V	Storage Temperature Range .....	-65°C to 150°C
TS Voltage (Continuous) .....	-5V to 70V	Lead Temperature (Soldering, 10 sec).....	300°C

## PACKAGE/ORDER INFORMATION

<p>MS8E PACKAGE 8-LEAD PLASTIC MSOP <math>T_{JMAX} = 125^{\circ}\text{C}</math>, <math>\theta_{JA} = 40^{\circ}\text{C/W}</math> (NOTE 4) EXPOSED PAD IS GND (PIN 9), MUST BE SOLDERED TO PCB</p>		<p>S6 PACKAGE 6-LEAD PLASTIC SOT-23 <math>T_{JMAX} = 125^{\circ}\text{C}</math>, <math>\theta_{JA} = 230^{\circ}\text{C/W}</math></p>	
ORDER PART NUMBER	MS8E PART MARKING	ORDER PART NUMBER	S6 PART MARKING
LTC4440EMS8E-5	LTBRG	LTC4440ES6-5	LTBRF
<b>Order Options</b> Tape and Reel: Add #TR Lead Free: Add #PBF Lead Free Tape and Reel: Add #TRPBF Lead Free Part Marking: <a href="http://www.linear.com/leadfree/">http://www.linear.com/leadfree/</a>			

Consult LTC Marketing for parts specified with wider operating temperature ranges.

## ELECTRICAL CHARACTERISTICS

The ● denotes specifications which apply over the full operating temperature range, otherwise specifications are at  $T_A = 25^{\circ}\text{C}$ .  $V_{CC} = V_{BOOST} = 6\text{V}$ ,  $V_{TS} = \text{GND} = 0\text{V}$ , unless otherwise noted.

SYMBOL	PARAMETER	CONDITIONS	MIN	TYP	MAX	UNITS
<b>Main Supply (<math>V_{CC}</math>)</b>						
$I_{VCC}$	DC Supply Current Normal Operation UVLO	INP = 0V $V_{CC} < \text{UVLO Threshold (Falling)} - 0.1\text{V}$		200 18	325 40	$\mu\text{A}$ $\mu\text{A}$
UVLO	Undervoltage Lockout Threshold	$V_{CC}$ Rising $V_{CC}$ Falling Hysteresis	● 2.75 ● 2.60	3.20 3.04	3.65 3.50	V V mV
<b>Bootstrapped Supply (BOOST – TS)</b>						
$I_{BOOST}$	DC Supply Current Normal Operation	INP = 0V INP = 6V		0 310	450	$\mu\text{A}$ $\mu\text{A}$
<b>Input Signal (INP)</b>						
$V_{IH}$	High Input Threshold	INP Ramping High	● 1.2	1.6	2	V
$V_{IL}$	Low Input Threshold	INP Ramping Low	● 0.8	1.25	1.6	V
$V_{IH} - V_{IL}$	Input Voltage Hysteresis			0.350		V
$I_{INP}$	Input Pin Bias Current			$\pm 0.01$	$\pm 2$	$\mu\text{A}$

44405fa

**ELECTRICAL CHARACTERISTICS** The ● denotes specifications which apply over the full operating temperature range, otherwise specifications are at  $T_A = 25^\circ\text{C}$ .  $V_{CC} = V_{\text{BOOST}} = 6\text{V}$ ,  $V_{\text{TS}} = \text{GND} = 0\text{V}$ , unless otherwise noted.

SYMBOL	PARAMETER	CONDITIONS	MIN	TYP	MAX	UNITS
<b>Output Gate Driver (TG)</b>						
$V_{\text{OH}}$	High Output Voltage	$I_{\text{TG}} = -10\text{mA}$ , $V_{\text{OH}} = V_{\text{BOOST}} - V_{\text{TG}}$		0.7		V
$V_{\text{OL}}$	Low Output Voltage	$I_{\text{TG}} = 100\text{mA}$	●	185	275	mV
$I_{\text{PU}}$	Peak Pull-Up Current		●	0.75	1.1	A
$R_{\text{DS}}$	Output Pull-Down Resistance		●	1.85	2.75	$\Omega$
<b>Switching Timing</b>						
$t_r$	Output Rise Time	10% – 90%, $C_L = 1\text{nF}$ 10% – 90%, $C_L = 10\text{nF}$		10 100		ns ns
$t_f$	Output Fall Time	10% – 90%, $C_L = 1\text{nF}$ 10% – 90%, $C_L = 10\text{nF}$		7 70		ns ns
$t_{\text{PLH}}$	Output Low-High Propagation Delay		●	35	65	ns
$t_{\text{PHL}}$	Output High-Low Propagation Delay		●	33	65	ns

**Note 1:** Absolute Maximum Ratings are those values beyond which the life of a device may be impaired.

**Note 2:** The LTC4440-5 is guaranteed to meet performance specifications from  $0^\circ\text{C}$  to  $85^\circ\text{C}$ . Specifications over the  $-40^\circ\text{C}$  to  $85^\circ\text{C}$  operating temperature range are assured by design, characterization and correlation with statistical process controls.

**Note 3:**  $T_J$  is calculated from the ambient temperature  $T_A$  and power dissipation PD according to the following formula:

$$T_J = T_A + (PD \cdot \theta_{JA}^\circ\text{C/W})$$

**Note 4:** Failure to solder the exposed back side of the MS8E package to the PC board will result in a thermal resistance much higher than  $40^\circ\text{C/W}$ .

**TYPICAL PERFORMANCE CHARACTERISTICS**

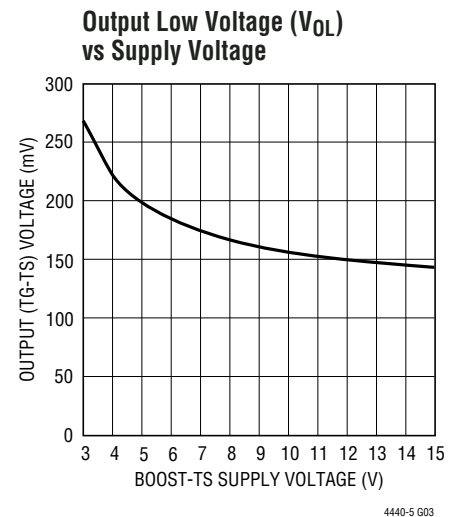
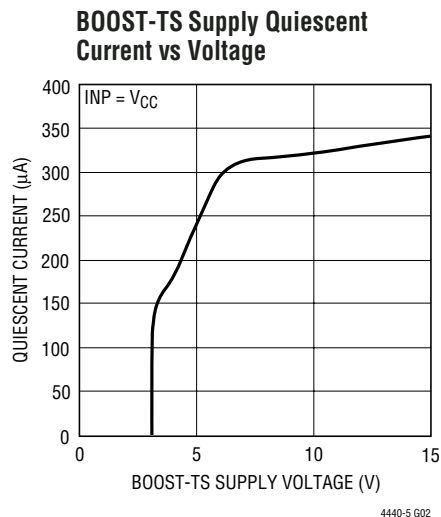
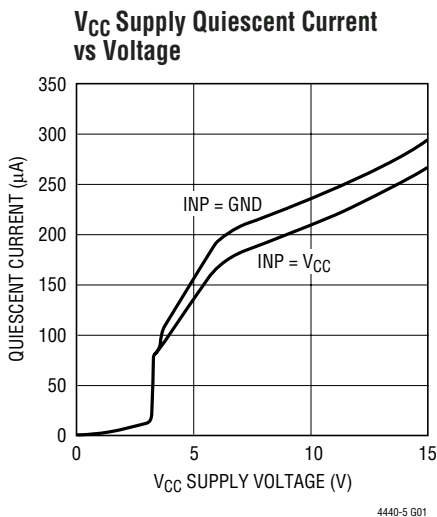

## TYPICAL PERFORMANCE CHARACTERISTICS

**Output High Voltage ( $V_{OH}$ ) vs Supply Voltage**

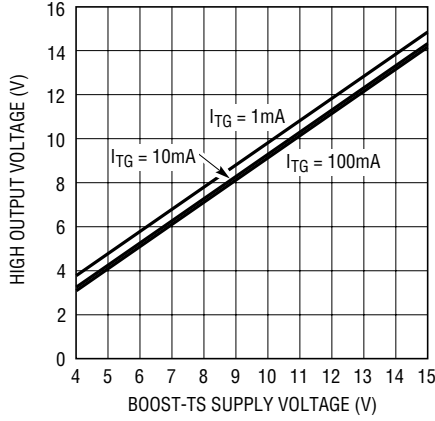

4440-5 G04

**Input (INP) Thresholds vs Supply Voltage**

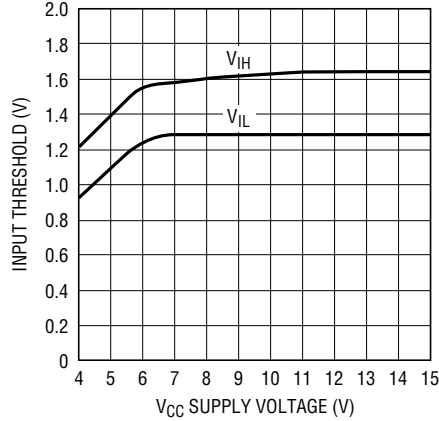

4440-5 G05

**2MHz Operation**

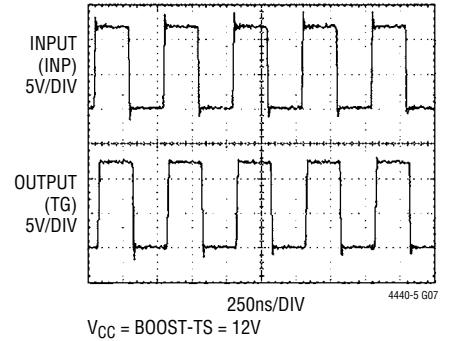

**$V_{CC}$  Supply Current vs Temperature**

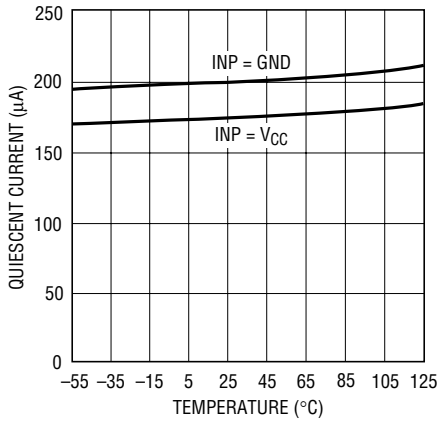

4440-5 G08

**$V_{CC}$  Undervoltage Lockout Thresholds vs Temperature**

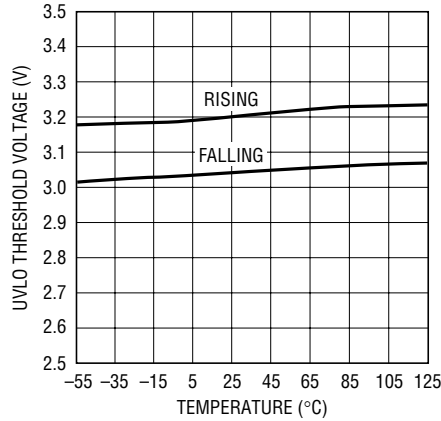

4440-5 G09

**BOOST-TS Quiescent Current vs Temperature**

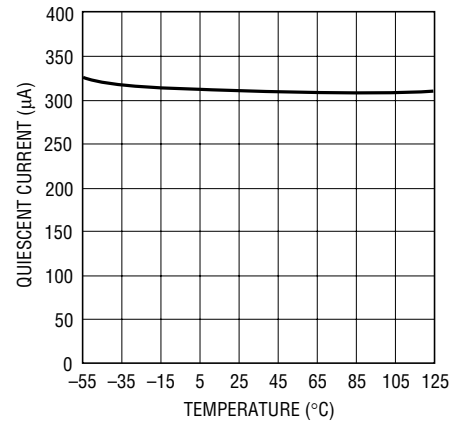

4440-5 G10

**Input (INP) Threshold vs Temperature**

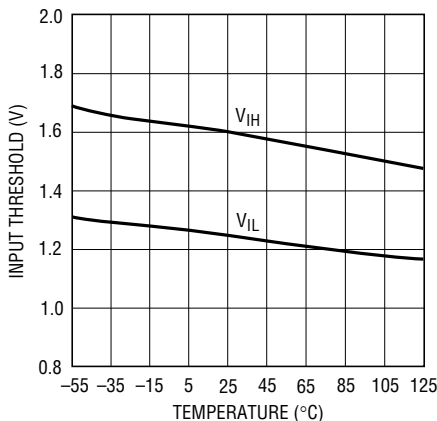

4440-5 G11

**Input Threshold Hysteresis vs Temperature**

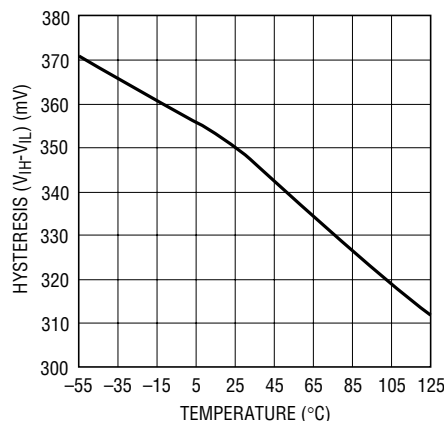

4440-5 G12

**Peak Driver (TG) Pull-Up Current vs Temperature**

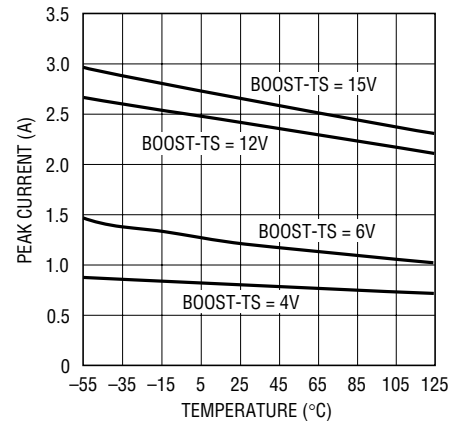

4440-5 G13

## TYPICAL PERFORMANCE CHARACTERISTICS

Output Driver Pull-Down Resistance vs Temperature

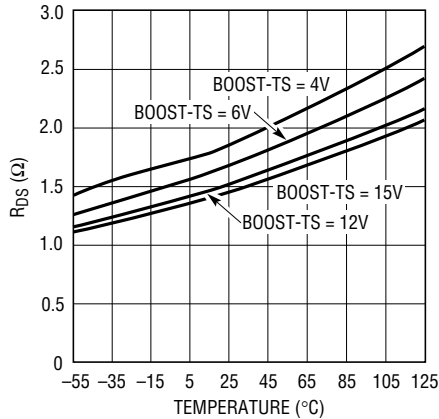

4440-5 G14

Propagation Delay vs Temperature

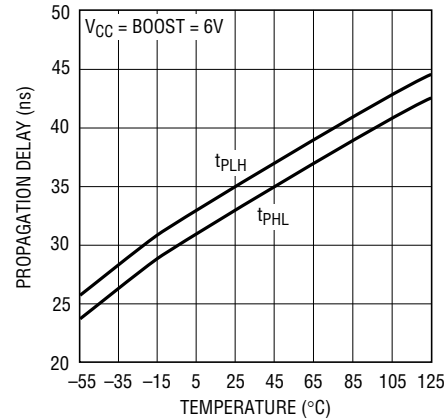

4440-5 G15

Driving a 3300pF Capacitive Load

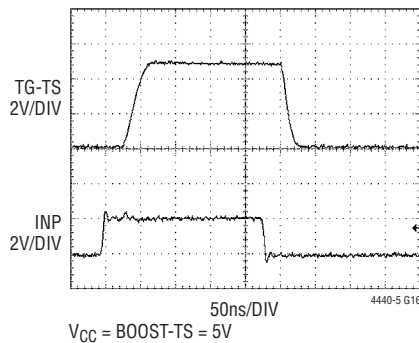

4440-5 G16

Driving a 3300pF Capacitive Load

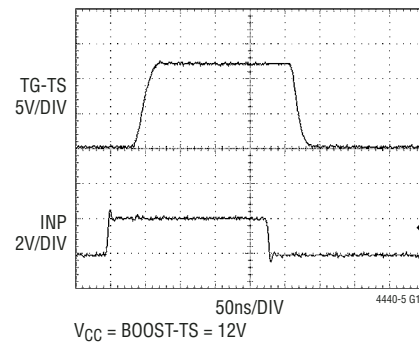

4440-5 G17

## PIN FUNCTIONS

### SOT-23 Package

**V<sub>CC</sub> (Pin 1):** Chip Supply. This pin powers the internal low side circuitry. A low ESR ceramic bypass capacitor should be tied between this pin and the GND pin (Pin 2).

**GND (Pin 2):** Chip Ground.

**INP (Pin 3):** Input Signal. TTL/CMOS compatible input referenced to GND (Pin 2).

**TS (Pin 4):** Top (High Side) source connection or GND if used in ground referenced applications.

**TG (Pin 5):** High Current Gate Driver Output (Top Gate). This pin swings between TS and BOOST.

**BOOST (Pin 6):** High Side Bootstrapped Supply. An external capacitor should be tied between this pin and TS (Pin 4). Normally, a bootstrap diode is connected between V<sub>CC</sub> (Pin 1) and this pin. Voltage swing at this pin is from V<sub>CC</sub> - V<sub>D</sub> to V<sub>IN</sub> + V<sub>CC</sub> - V<sub>D</sub>, where V<sub>D</sub> is the forward voltage drop of the bootstrap diode.

## PIN FUNCTIONS

### Exposed Pad MS8E Package

**INP (Pin 1):** Input Signal. TTL/CMOS compatible input referenced to GND (Pin 2).

**GND (Pins 2, 4):** Chip Ground.

**V<sub>CC</sub> (Pin 3):** Chip Supply. This pin powers the internal low side circuitry. A low ESR ceramic bypass capacitor should be tied between this pin and the GND pin (Pin 2).

**NC (Pin 5):** No Connect. No connection required. For convenience, this pin may be tied to Pin 6 (BOOST) on the application board.

**BOOST (Pin 6):** High Side Bootstrapped Supply. An external capacitor should be tied between this pin and TS (Pin 8). Normally, a bootstrap diode is connected between V<sub>CC</sub> (Pin 3) and this pin. Voltage swing at this pin is from V<sub>CC</sub> - V<sub>D</sub> to V<sub>IN</sub> + V<sub>CC</sub> - V<sub>D</sub>, where V<sub>D</sub> is the forward voltage drop of the bootstrap diode.

**TG (Pin 7):** High Current Gate Driver Output (Top Gate). This pin swings between TS and BOOST.

**TS (Pin 8):** Top (High Side) source connection or GND if used in ground referenced applications.

**Exposed Pad (Pin 9):** Ground. Must be electrically connected to Pins 2 and 4 and soldered to PCB ground for optimum thermal performance.

## BLOCK DIAGRAM

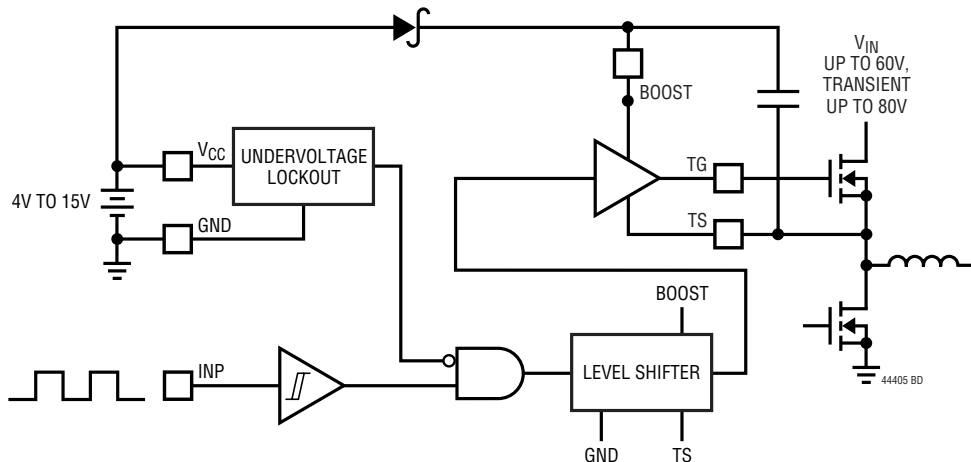

## TIMING DIAGRAM

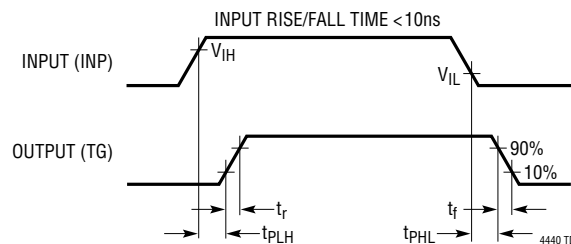

## APPLICATIONS INFORMATION

### Overview

The LTC4440-5 receives a ground-referenced, low voltage digital input signal to drive a high side N-channel power MOSFET whose drain can float up to 80V above ground, eliminating the need for a transformer between the low voltage control signal and the high side gate driver. The LTC4440-5 normally operates in applications with input supply voltages ( $V_{IN}$ ) up to 60V, but is able to withstand and continue to function during 80V, 100ms transients on the input supply.

The powerful output driver of the LTC4440-5 reduces the switching losses of the power MOSFET, which increase with transition time. The LTC4440-5 is capable of driving a 1nF load with 10ns rise and 7ns fall times using a bootstrapped supply voltage  $V_{BOOST-TS}$  of 6V.

### Input Stage

The LTC4440-5 employs TTL/CMOS compatible input logic level or thresholds that allow a low voltage digital signal to drive standard threshold power MOSFETs. The LTC4440-5 contains an internal voltage regulator that biases the input buffer, allowing the input thresholds ( $V_{IH} = 1.6V$ ,  $V_{IL} = 1.25V$ ) to be relatively independent of variations in  $V_{CC}$ . The 350mV hysteresis between  $V_{IH}$  and  $V_{IL}$  eliminates false triggering due to noise during switching transitions. However, care should be taken to keep this pin from any noise pickup, especially in high frequency, high voltage applications. The LTC4440-5 input buffer has a high input impedance and draws negligible input current, simplifying the drive circuitry required for the input.

### Output Stage

A simplified version of the LTC4440-5's output stage is shown in Figure 1. The pull-down device is an N-channel MOSFET (N1) and the pull-up device is an NPN bipolar junction transistor (Q1). The output swings from the lower rail (TS) to within an NPN  $V_{BE}$  ( $\sim 0.7V$ ) of the positive rail (BOOST). This large voltage swing is important in driving external power MOSFETs, whose  $R_{DS(ON)}$  is inversely proportional to its gate overdrive voltage ( $V_{GS} - V_{TH}$ ).

The LTC4440-5's peak pull-up (Q1) current is 1.1A while the pull-down (N1) resistance is 1.85 $\Omega$ , with a BOOST-TS supply of 6V. The low impedance of N1 is required to

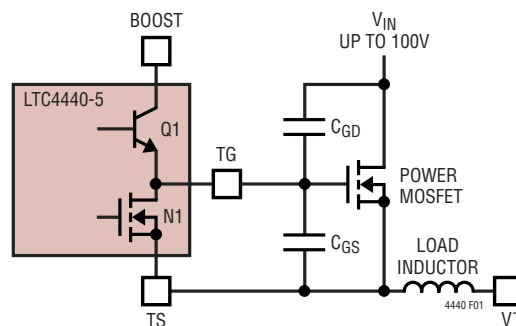

Figure 1. Capacitance Seen by TG During Switching

discharge the power MOSFET's gate capacitance during high-to-low signal transitions. When the power MOSFET's gate is pulled low (gate shorted to source through N1) by the LTC4440-5, its source (TS) is pulled low by its load (e.g., an inductor or resistor). The slew rate of the source/gate voltage causes current to flow back to the MOSFET's gate through the gate-to-drain capacitance ( $C_{GD}$ ). If the MOSFET driver does not have sufficient sink current capability (low output impedance), the current through the power MOSFET's  $C_{GD}$  can momentarily pull the gate high, turning the MOSFET back on.

A similar scenario exists when the LTC4440-5 is used to drive a low side MOSFET. When the low side power MOSFET's gate is pulled low by the LTC4440-5, its drain voltage is pulled high by its load (e.g., inductor or resistor). The slew rate of the drain voltage causes current to flow back to the MOSFET's gate through its gate-to-drain capacitance. If the MOSFET driver does not have sufficient sink current capability (low output impedance), the current through the power MOSFET's  $C_{GD}$  can momentarily pull the gate high, turning the MOSFET back on.

### Rise/Fall Time

Since the power MOSFET generally accounts for the majority of the power loss in a converter, it is important to quickly turn it on or off, thereby minimizing the transition time in its linear region. The LTC4440-5 can drive a 1nF load with a 10ns rise time and 7ns fall time.

The LTC4440-5's rise and fall times are determined by the peak current capabilities of Q1 and N1. The predriver that drives Q1 and N1 uses a nonoverlapping transition scheme to minimize cross-conduction currents. N1 is fully turned off before Q1 is turned on and vice versa.

44405fa

## APPLICATIONS INFORMATION

### Power Dissipation

To ensure proper operation and long-term reliability, the LTC4440-5 must not operate beyond its maximum temperature rating. Package junction temperature can be calculated by:

$$T_J = T_A + PD (\theta_{JA})$$

where:

$T_J$  = Junction Temperature

$T_A$  = Ambient Temperature

PD = Power Dissipation

$\theta_{JA}$  = Junction-to-Ambient Thermal Resistance

Power dissipation consists of standby and switching power losses:

$$PD = P_{STDBY} + P_{AC}$$

where:

$P_{STDBY}$  = Standby Power Losses

$P_{AC}$  = AC Switching Losses

The LTC4440-5 consumes very little current during standby. The DC power loss at  $V_{CC} = 6V$  and  $V_{BOOST-TS} = 6V$  is only  $(250\mu A)(5V) = 1.2mW$  with  $INP = 0V$ .

AC switching losses are made up of the output capacitive load losses and the transition state losses. The capacitive load losses are primarily due to the large AC currents needed to charge and discharge the load capacitance during switching. Load losses for the output driver driving a pure capacitive load  $C_{OUT}$  would be:

$$\text{Load Capacitive Power} = (C_{OUT})(f)(V_{BOOST-TS})^2$$

The power MOSFET's gate capacitance seen by the driver output varies with its  $V_{GS}$  voltage level during switching. A power MOSFET's capacitive load power dissipation can be calculated using its gate charge,  $Q_G$ . The  $Q_G$  value corresponding to the MOSFET's  $V_{GS}$  value ( $V_{CC}$  in this case) can be readily obtained from the manufacturer's  $Q_G$  vs  $V_{GS}$  curves:

$$\text{Load Capacitive Power (MOS)} = (V_{BOOST-TS})(Q_G)(f)$$

Transition state power losses are due to both AC currents required to charge and discharge the driver's internal

nodal capacitances and cross-conduction currents in the internal gates.

### Undervoltage Lockout (UVLO)

The LTC4440-5 contains an undervoltage lockout detector that monitors  $V_{CC}$ . When  $V_{CC}$  falls below 3.04V, the internal buffer is disabled and the output pin TG is pulled down to TS.

### Bypassing and Grounding

The LTC4440-5 requires proper bypassing on the  $V_{CC}$  and  $V_{BOOST-TS}$  supplies due to its high speed switching (nanoseconds) and large AC currents (Amperes). Careless component placement and PCB trace routing may cause excessive ringing and under/overshoot.

To obtain the optimum performance from the LTC4440-5:

- A. Mount the bypass capacitors as close as possible between the  $V_{CC}$  and GND pins and the BOOST and TS pins. The leads should be shortened as much as possible to reduce lead inductance.
- B. Use a low inductance, low impedance ground plane to reduce any ground drop and stray capacitance. Remember that the LTC4440-5 switches  $>2A$  peak currents and any significant ground drop will degrade signal integrity.
- C. Plan the power/ground routing carefully. Know where the large load switching current is coming from and going to. Maintain separate ground return paths for the input pin and the output power stage.
- D. Keep the copper trace between the driver output pin and the load short and wide.
- E. When using the MS8E package, be sure to solder the exposed pad on the back side of the LTC4440-5 package to the board. Correctly soldered to a 2500mm<sup>2</sup> double-sided 1oz copper board, the LTC4440-5 has a thermal resistance of approximately 40°C/W. Failure to make good thermal contact between the exposed back side and the copper board will result in thermal resistances far greater than 40°C/W.



TYPICAL APPLICATIONS

LTC3722/LTC4440-5 420W 36V-60V<sub>IN</sub> to 12V/35A Isolated Full-Bridge Supply

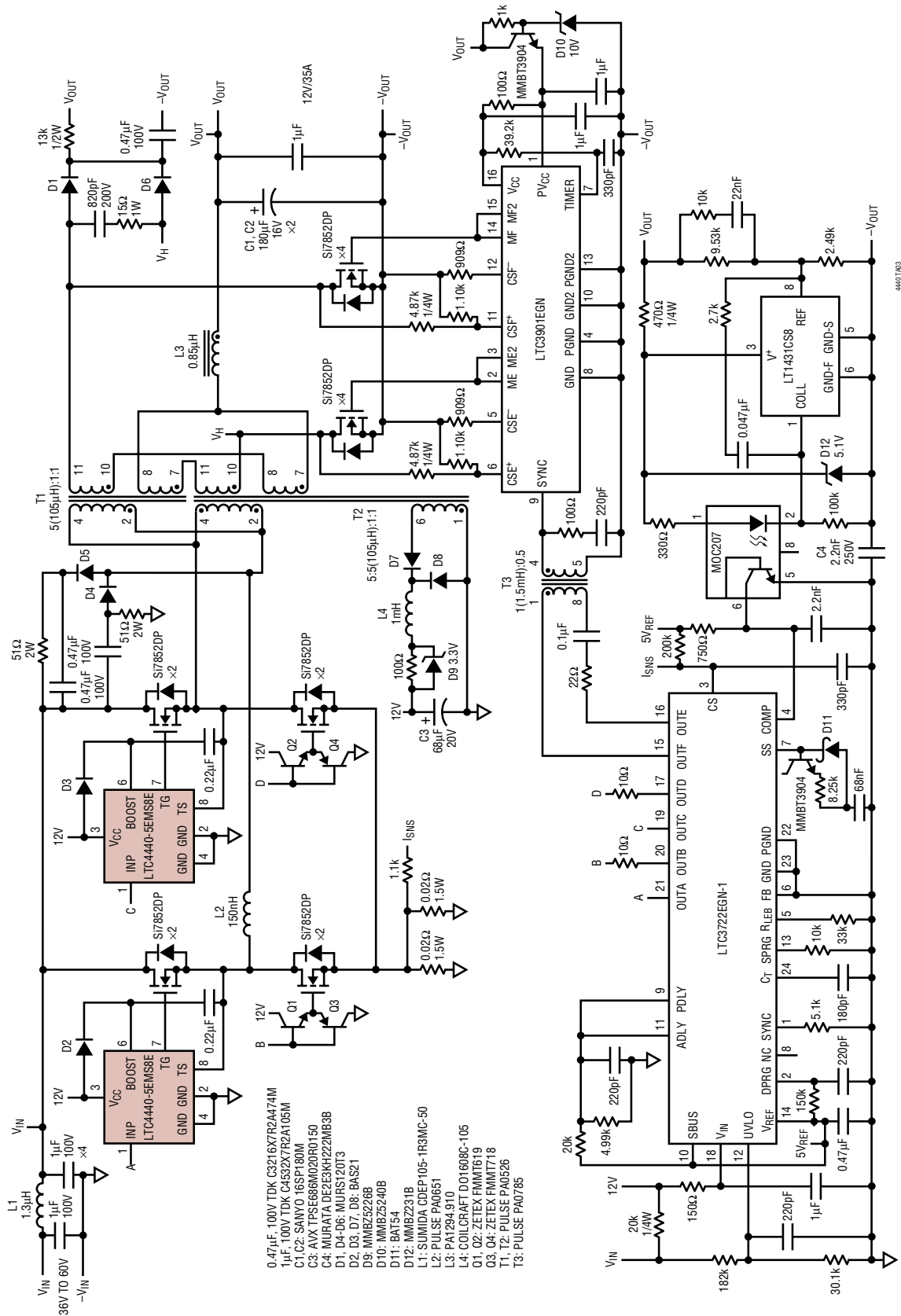

- 0.47µF, 100V TDK C3216X7R2A474M
- 1µF, 100V TDK C4532X7R2A105M
- C1, C2: SANYO 165P180M
- C3: AVX TPSE686M020R0150
- C4: MURATA DEZE3KH222MB3B
- D1, D4-D6: MURS120T3
- D2, D3, D7, D8: BAS21
- D9: MMBZ5226B
- D10: MMBZ5240B
- D11: BA754
- D12: MMBZ5231B
- L1: SUMIDA CDEP-05-1R3MC-50
- L2: PULSE PA0651
- L3: PA1294.910
- L4: COILCRAFT D01608C-105
- O1, O2: ZETEX FMMT619
- O3, O4: ZETEX FMMT718
- T1, T2: PULSE PA0526
- T3: PULSE PA0785

4440783

TYPICAL APPLICATIONS

LTC3723-1 240W 42-56V<sub>IN</sub> to 12V/20A Isolated 1/4Brick (2.3" × 1.45")

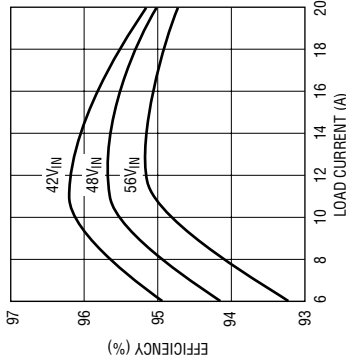
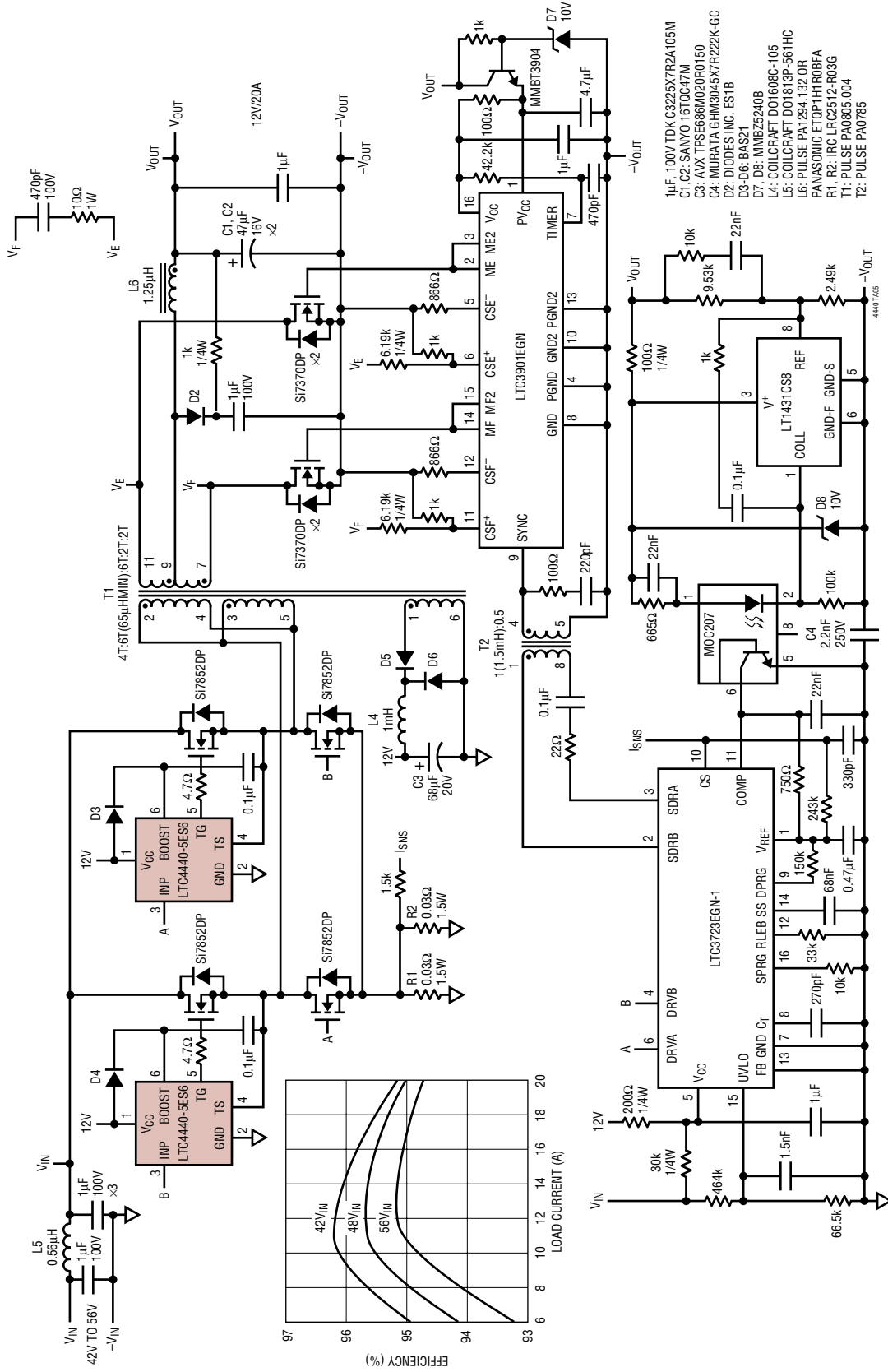

# PACKAGE DESCRIPTION

## MS8E Package 8-Lead Plastic MSOP (Reference LTC DWG # 05-08-1662)

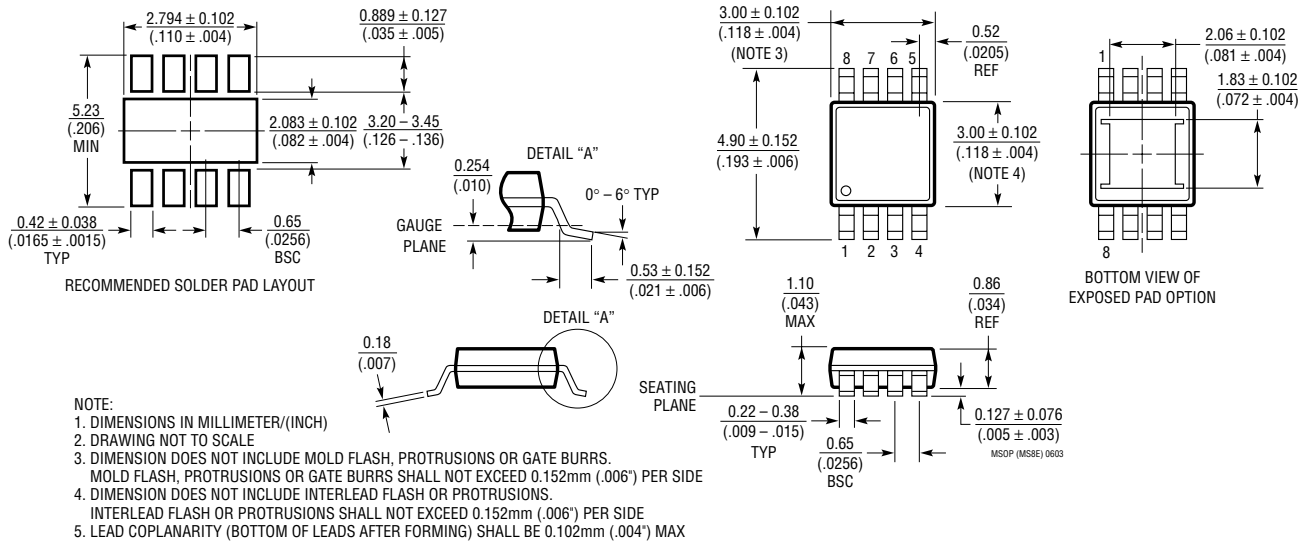

## S6 Package 6-Lead Plastic TSOT-23 (Reference LTC DWG # 05-08-1636)

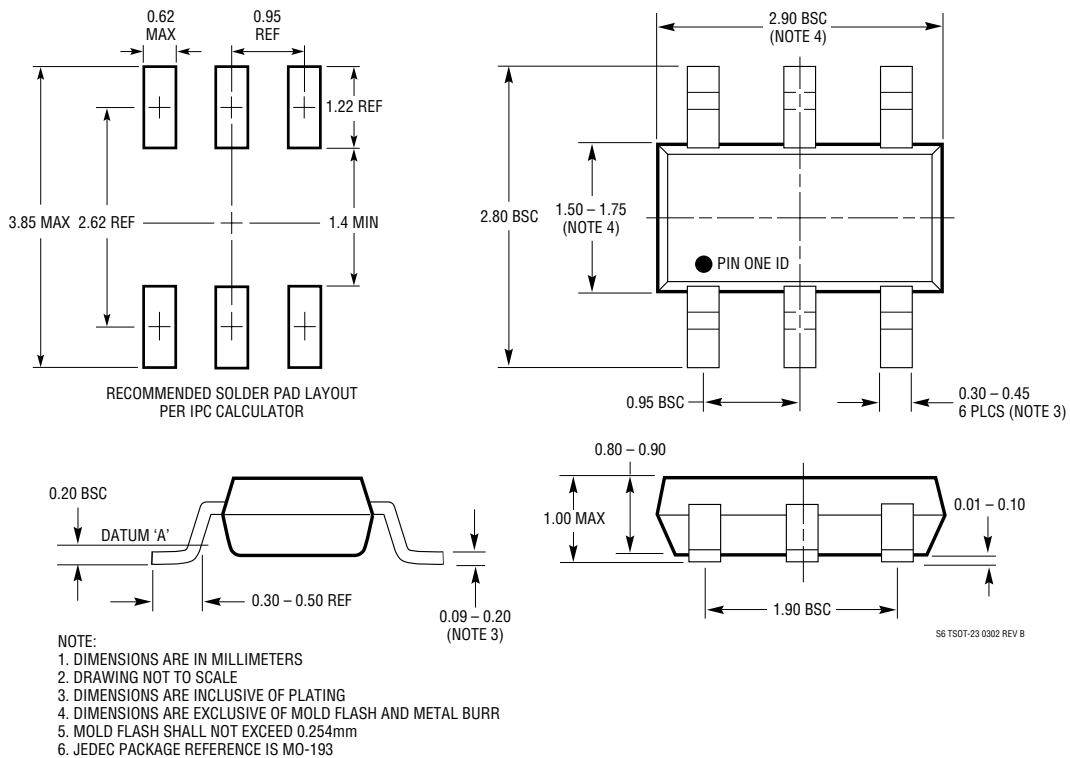

S6 TSOT-23 0302 REV B

## TYPICAL APPLICATION

### 240W 42V-56V<sub>IN</sub> to Unregulated 12V Half-Bridge Converter

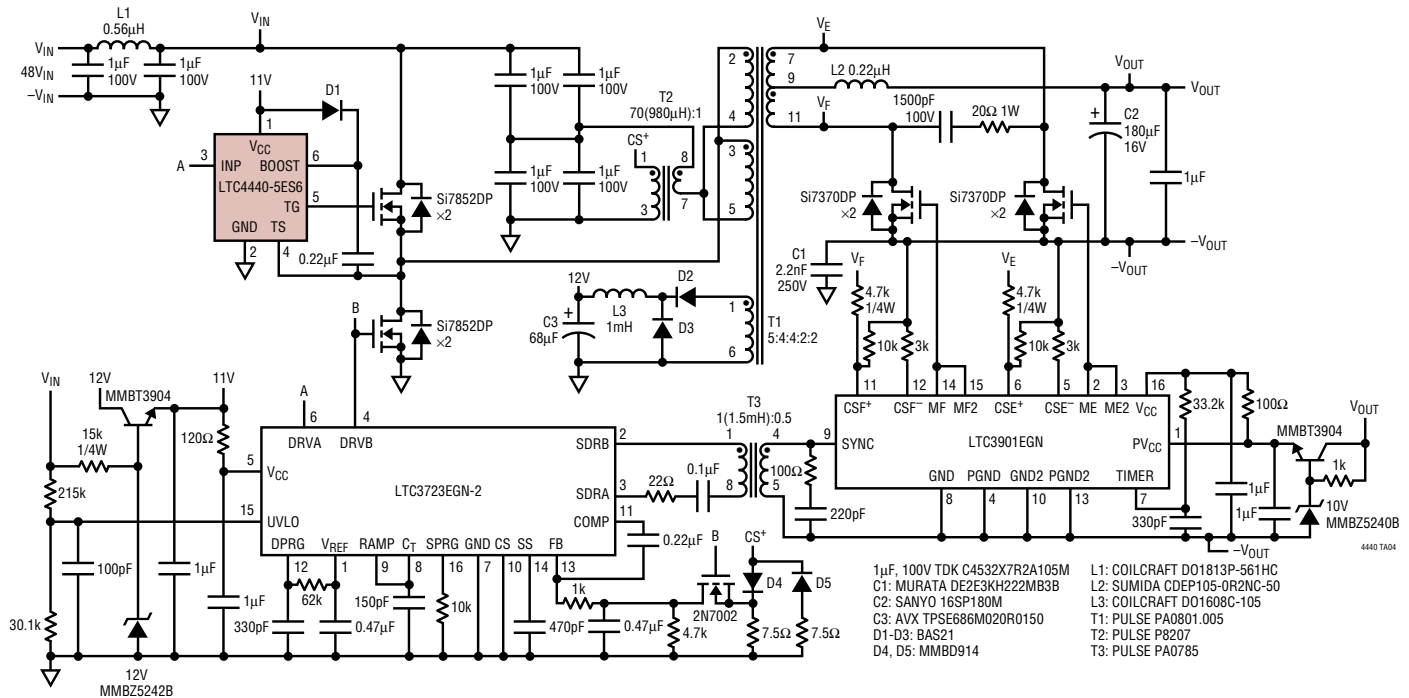

## RELATED PARTS

PART NUMBER	DESCRIPTION	COMMENTS
LT®1161	Quad Protected High Side MOSFET Driver	8V to 48V Supply Range, $t_{ON} = 200\mu s$ , $t_{OFF} = 28\mu s$
LTC1693 Family	High Speed Dual MOSFET Drivers	1.5A Peak Output Current, $4.5V \leq V_{IN} \leq 13.2V$
LT1952	Single Switch Synchronous Forward Controller	25W to 500W DC/DC Controller
LT3010/LT3010-5	50mA, 3V to 80V Low Dropout Micropower Regulators	Low Quiescent Current (30µA), Stable with Small (1µF) Ceramic Capacitor
LT3430	High Voltage, 3A, 200kHz Step-Down Switching Regulator	Input Voltages Up to 60V, Internal 0.1Ω Power Switch, Current Mode Architecture, 16-Pin Exposed Pad TSSOP Package
LTC3705 Family	Isolated Power Supply Chipset	Primary and Secondary Side Controllers; Simple as Buck Circuit; PolyPhase® Operation
LTC3722-1/ LTC3722-2	Synchronous Dual Mode Phase Modulated Full-Bridge Controllers	Adaptive Zero Voltage Switching, High Output Power Levels (Up to Kilowatts)
LTC3723-1/ LTC3723-2	Synchronous Push-Pull PWM Controllers	Current Mode or Voltage Mode Push-Pull Controllers
LT3781/LTC1698	36V to 72V Input Isolated DC/DC Converter Chip Set	Synchronous Rectification; Overcurrent, Overvoltage, UVLO Protection; Power Good Output Signal; Voltage Margining; Compact Solution
LT3804	Secondary Side Dual Output Controller with Opto Driver	Regulates Two Secondary Outputs, Optocoupler Feedback Divider and Second Output Synchronous Driver Controller
LTC3900	Synchronous Rectifier Driver for Forward Converters	Programmable Time Out, Reverse Inductor Current Sense
LTC3901	Secondary Side Synchronous Driver for Push-Pull and Full-Bridge Converters	Programmable Time Out, Reverse Inductor Current Sense
LTC4440	High Speed, High Voltage, High Side Gate Driver	High Side Source up to 100V, 8V to 15V Gate Drive Supply, Undervoltage Lockout, 6-Lead ThinSOT or 8-Lead Exposed MSOP Package
LTC4441	6A MOSFET Driver	Adjustable Gate Drive from 5V to 8V, $5V \leq V_{IN} \leq 28V$

PolyPhase is a registered trademark of Linear Technology Corporation.