



PAM2845

40V High Power Boost Converter with 6 Channel Constant Current Source

Features

- Six Constant-Current Output Channels
- Parallel Channels Allow Higher Current per LED String
- Maximum 40V Continuous Voltage Output Limit for Each Channel
- Adjustable Constant Output Voltage
- Adjustable Constant LED Current
- Drives 10 or more LEDs Each String as Long as the String Voltage Less Than 40V
- Internal 2.5A Power MOSFET
- Allows Digital PWM and Analog Dimming
- Wide (100:1) PWM Dimming Range without Color Shift
- Independent Dimming and Shutdown Control of the LED Driver
- $\pm 1\%$ Typical Current Matching between Strings
- Short LED Protection
- 3 Frequencies Selection: 1.6MHz/1MHz/500kHz
- Wide Input Voltage Range: 4.8V to 28V
- Over Temperature Protection
- Available in 24-pin 4mmx4mm QFN Package
- Pb-free Package

Applications

- White or RGB Backlighting for LCD TV, LCD Monitor, Notebook, Handy Terminals, and Avionics Displays Panels
- LED Lighting Devices

Description

The PAM2845 is a high-efficiency boost type LED driver. It is designed for large LCD panel that employs an array of LEDs as back light source.

The PAM2845 employs a current-mode step-up converter that drives six parallel strings of LEDs connected in multiple series. This built-in string-current-control circuit achieves $\pm 1\%$ typical current matching between strings, which ensures even brightness for all LEDs.

Separate feedback loops limit the output voltage if one or more LEDs open or short. The PAM2845 has features cycle-by-cycle current limit to provide consistent operation and soft-start capability. A thermal-shutdown circuit provides another level of protection.

The PAM2845 has a wide +4.8V to +28V input-voltage range and provides adjustable full-scale LED current. The switching frequency of this device can be selected among 500kHz, 1MHz and 1.6MHz according to the application requirements.

Typical Application

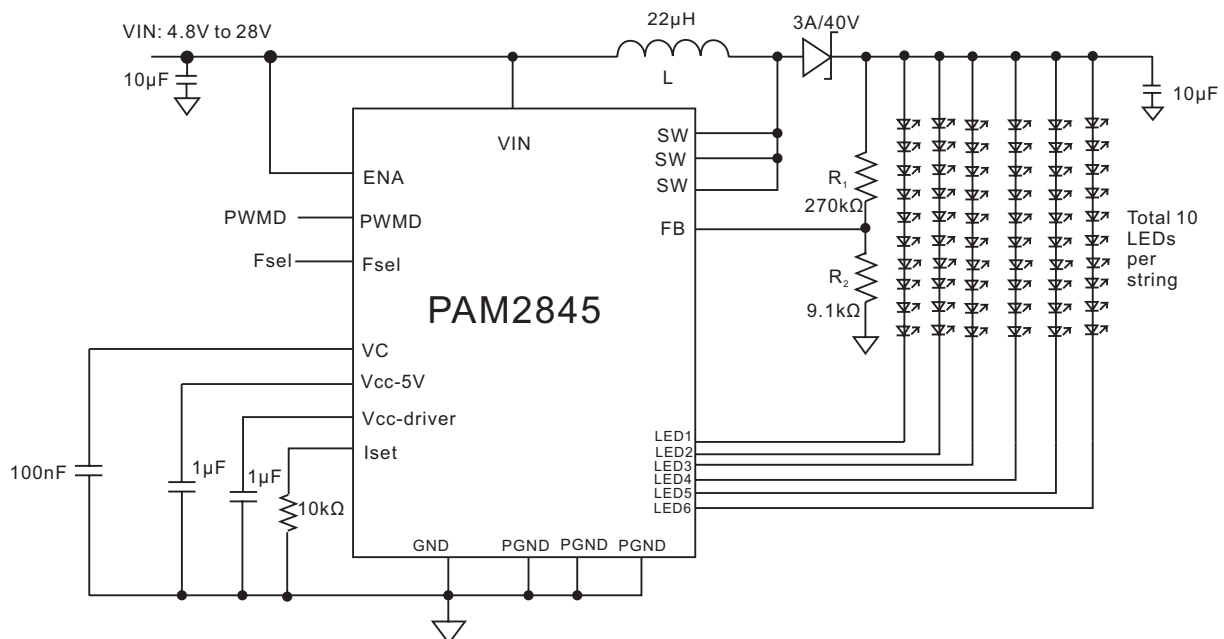



PAM2845

40V High Power Boost Converter with 6 Channel Constant Current Source

Block Diagram

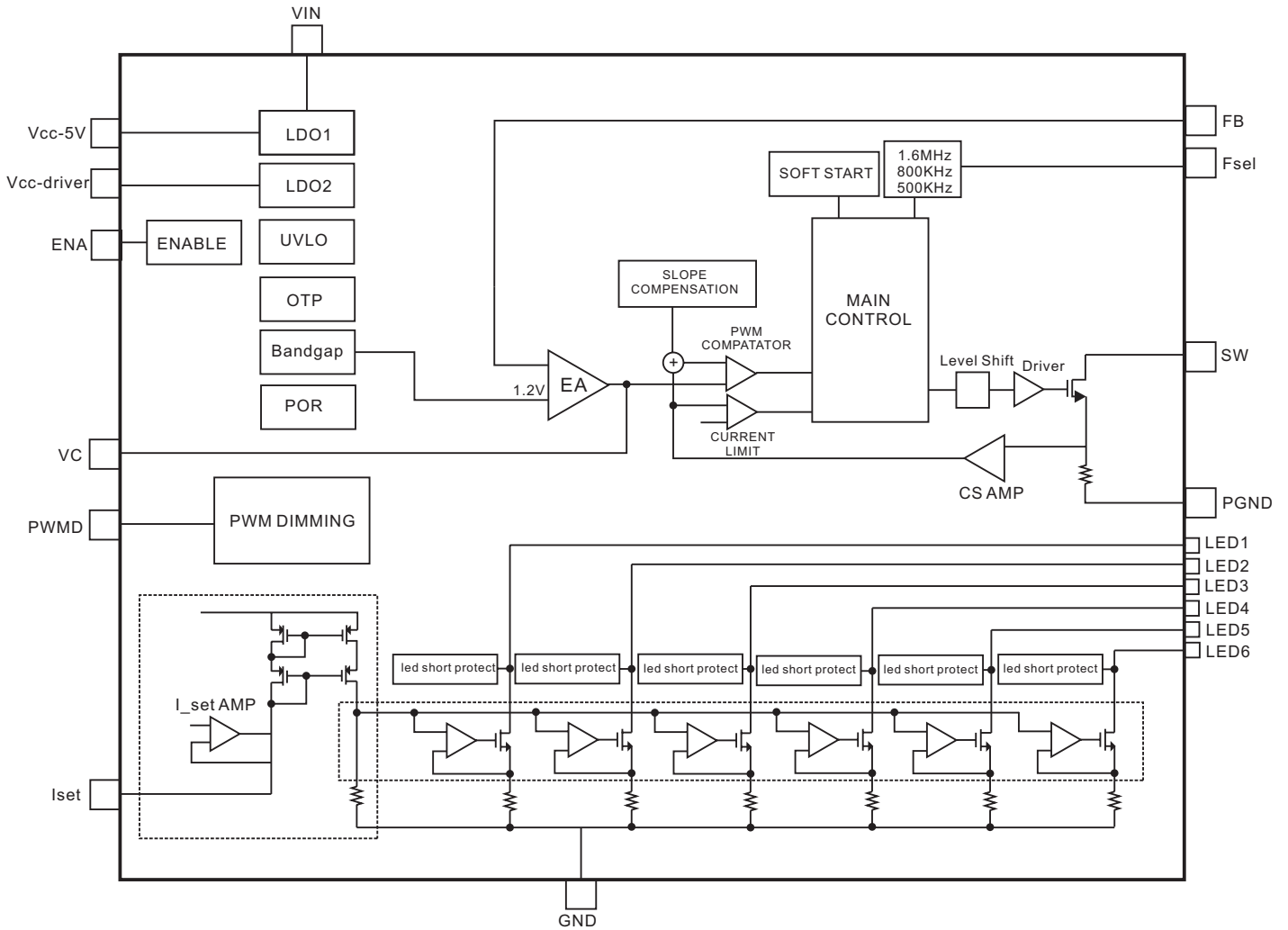

Pin Configuration

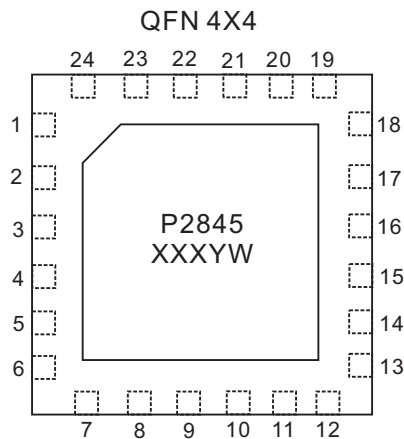

X: Internal Code
Y: Year
W: Week

Pin Descriptions

Pin Number	Name	Description
1	VIN	Supply input
2	Vcc-driver	5V linear regulator output for power MOS driver
3	GND	Ground
4	ENA	Enable input
5	PWMD	PWM dimming control
6	LED1	LED1 cathode terminal
7	LED2	LED2 cathode terminal
8	LED3	LED3 cathode terminal
9	GND	Ground
10	GND	Ground
11	LED4	LED4 cathode terminal
12	LED5	LED5 cathode terminal
13	LED6	LED6 cathode terminal
14	Iset	LED current adjustment pin
15	Vcc-5V	5V linear regulator output
16	VC	Boost stage compensation pin
17	Fsel	Oscillator frequency selection pin
18	FB	Feedback
19	PGND	Power ground
20	PGND	Power ground
21	PGND	Power ground
22	SW	Power MOS drain
23	SW	Power MOS drain
24	SW	Power MOS drain



PAM2845

40V High Power Boost Convertor with 6 Channel Constant Current Source

Absolute Maximum Ratings

These are stress ratings only and functional operation is not implied. Exposure to absolute maximum ratings for prolonged time periods may affect device reliability. All voltages are with respect to ground.

VIN,ENA.....	-0.3V To +30V	Operating Temperature.....	-40°C to 125°C
SW ,LED.....	-0.3V To +40V	Storage Temperature.....	-40°C to 150°C
Vcc-5V,Vcc-driver,VC.....	-0.3V To +6V	Maximum Junction Temperature.....	150°C
PWMD,Fsel,FB,Iset.....	-0.3V To +6V	Soldering Temperature.....	300°C,5sec

Recommended Operating Conditions

Supply Voltage Range.....	4.8V to 28V	Operation Temperature Range.....	-20°C to 85°C
---------------------------	-------------	----------------------------------	---------------

Thermal Information

Parameter	Package	Symbol	Maximum	Unit
Thermal Resistance (Junction to Case)	4x4mm QFN	θ_{jc}	20	°C/W
Thermal Resistance (Junction to Environment)	4x4mm QFN	θ_{jA}	37	°C/W



PAM2845

40V High Power Boost Convertor with 6 Channel Constant Current Source

Electrical Characteristic

$T_A=25^{\circ}\text{C}$, $V_{IN}=ENA=12\text{V}$, $L=22\mu\text{H}$, $R_{set}=10\text{k}\Omega$, unless otherwise noted

PARAMETER	Conditions	Min	Typ	Max	Units
Input Voltage Range		4.8		28	V
Quiescent Current	ENA=high (no switching)		1	2	mA
	Fsel=high (1.6M switching frequency)		10		
	Fsel =high (1M switching frequency)		6		
	Fsel =high (500k switching frequency)		3		
	ENA=low		5	20	μA
LDO Stage					
Vcc_5V		4.5	5	5.5	V
Vcc_5V current_limit		14	74	90	mA
Vcc_5V UVLO Threshold		3.9	4.2	4.5	V
Vcc_5V UVLO Hysteresis			70		mV
Vcc_driver		4.5	5	5.5	V
Vcc_driver current_limit		14	74	90	mA
Vcc_driver UVLO Threshold		3.9	4.2	4.5	V
Vcc_driver UVLO Hysteresis			70		mV
Boost Stage					
Feedback Voltage			1.2		V
Switch Rdson	Vcc_5V=5V		0.2		Ω
Switch Current Limit			2.5		A
Switch Leakage Current			1		μA
Switching Frequency	Fsel =Vcc_5V		1.6		MHz
	Fsel =Open		1.0		MHz
	Fsel =Gnd		500		kHz
Minimums Duty Cycle	Fsel =Vcc_5V		20		%
	Fsel =Open		10		%
	Fsel =Gnd		5		%
Maximums Duty Cycle			90		%
VC Source Current			60		μA
VC Sink Current			60		μA



PAM2845

40V High Power Boost Convertor with 6 Channel Constant Current Source

Electrical Characteristic

$T_A=25^{\circ}\text{C}$, $V_{IN}=ENA=12\text{V}$, $L=22\mu\text{H}$, $R_{set}=10\text{k}\Omega$, unless otherwise noted.

PARAMETER	Conditions	Min	Typ	Max	Units
LED Controller Stage					
Full-Scale LED_ Output Current	$I=190*1.2\text{V}/R_{set}$, $R_{set}=7.68\text{k}$		30		mA
	$I=190*1.2\text{V}/R_{set}$, $R_{set}=11.3\text{k}$		20		mA
	$I=190*1.2\text{V}/R_{set}$, $R_{set}=22.6\text{k}$		10		mA
LED current matching		-3	1	+3	%
Iset Voltage			1.2		V
Minimums LED voltage			400		mV
Analog Dimming Range	$I=190*1.2\text{V} / R_{set}$	$I/32$		I	mA
PWM Dimming Frequency		100		1k	Hz
Fault Protection					
LED_ Overvoltage Threshold		4.6	4.9	5.1	V
LED_ Overvoltage Hysteresis			1		V
Thermal-Shutdown			150		$^{\circ}\text{C}$
Thermal-Shutdown Hysteresis			30		$^{\circ}\text{C}$
Controll Interface					
EN High		1.5			V
EN Low				0.4	V
PWMD High		1.5			V
PWMD Low				0.4	V
Fsel High		$V_{cc_5V-0.5}$			V
Fsel Midlevel		1		2	V
Fsel Low				0.5	V
EN Min pulse width		0.5			μs
EN Max pulse width				10	μs
EN off delay			100		μs



PAM2845

40V High Power Boost Convertor with 6 Channel Constant Current Source

Typical Performance Characteristic

$T_A=25^\circ\text{C}$, $V_{IN}=E_{NA}=12\text{V}$, $L=22\mu\text{H}$, $R_{set}=10\text{k}\Omega$, unless otherwise noted.

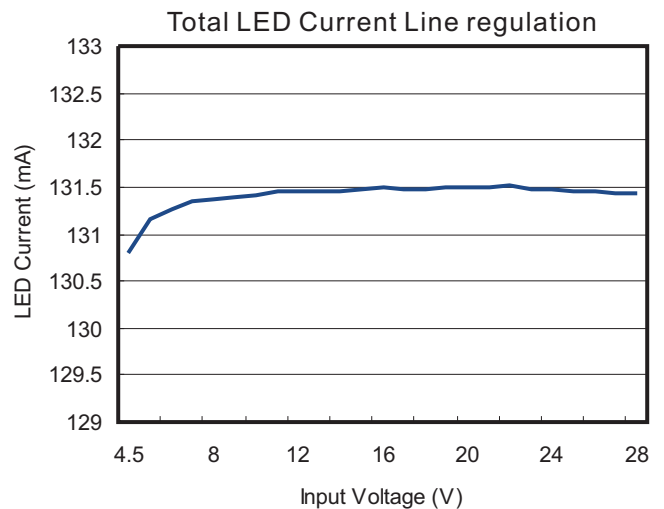
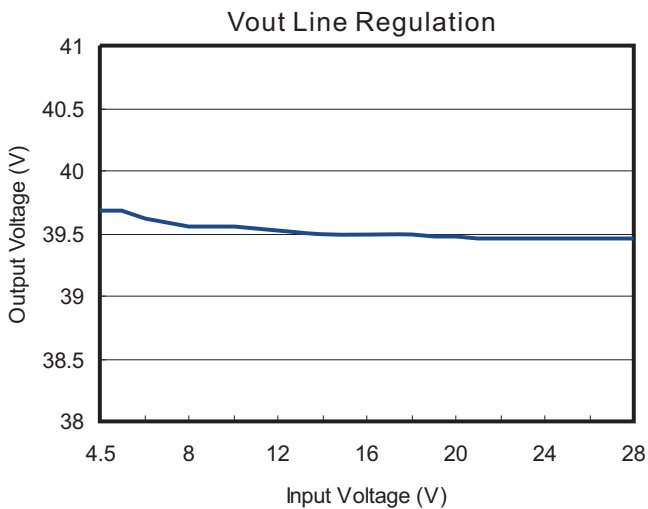
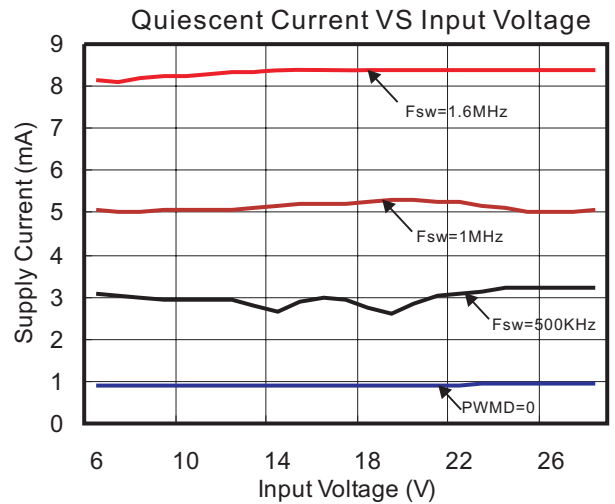
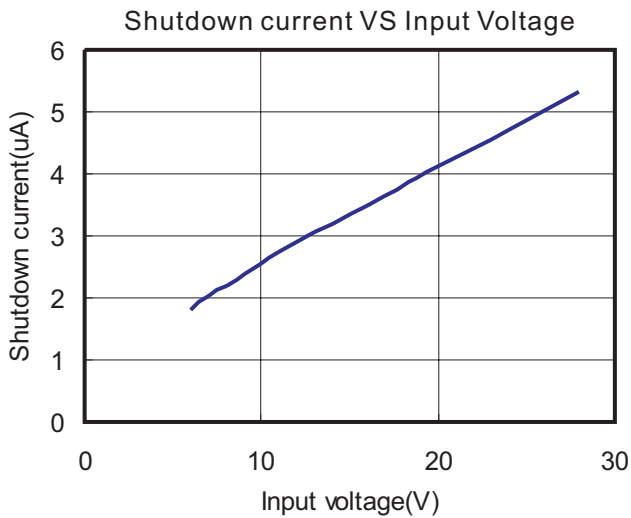
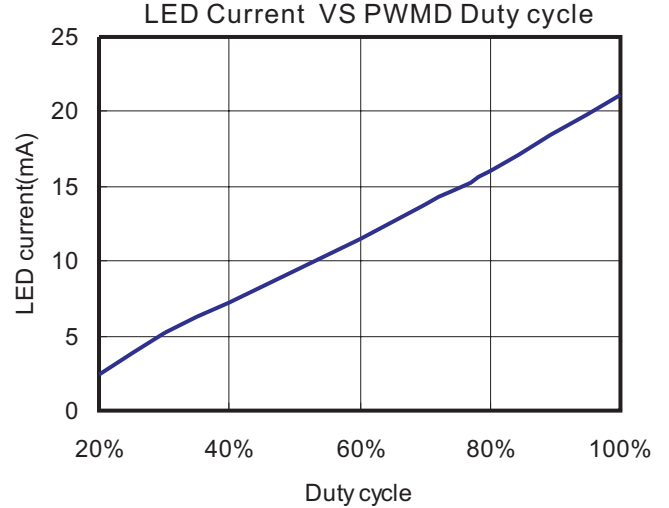
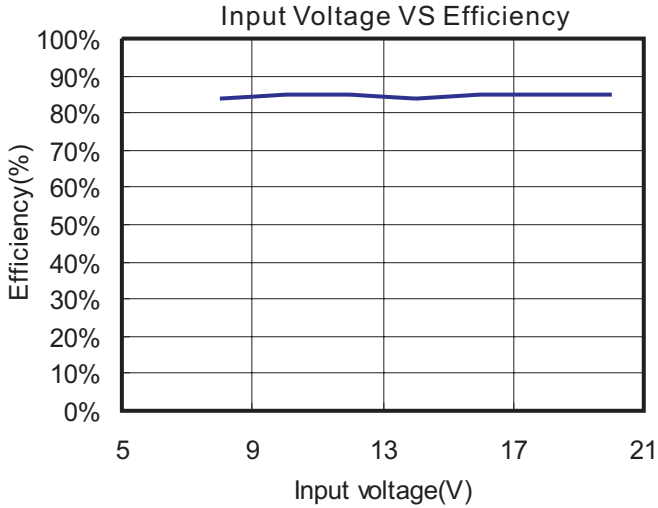



PAM2845

40V High Power Boost Converter with 6 Channel Constant Current Source

Typical Performance Characteristic

$T_A=25^\circ\text{C}$, $V_{IN}=E_{NA}=12\text{V}$, $L=22\mu\text{H}$, $R_{set}=10\text{k}\Omega$, unless otherwise noted.

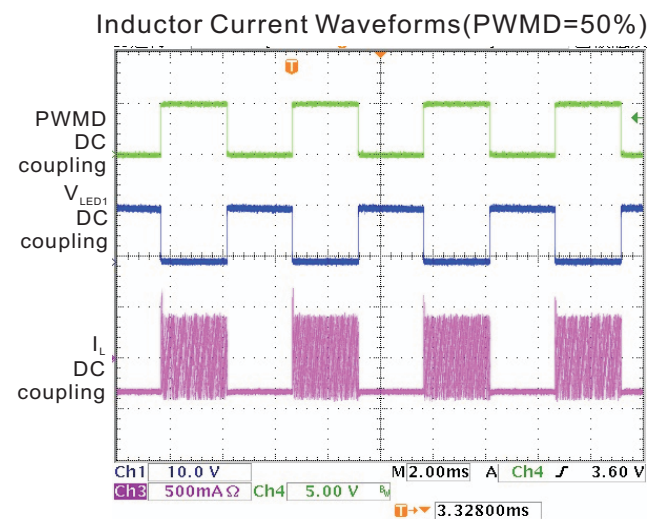
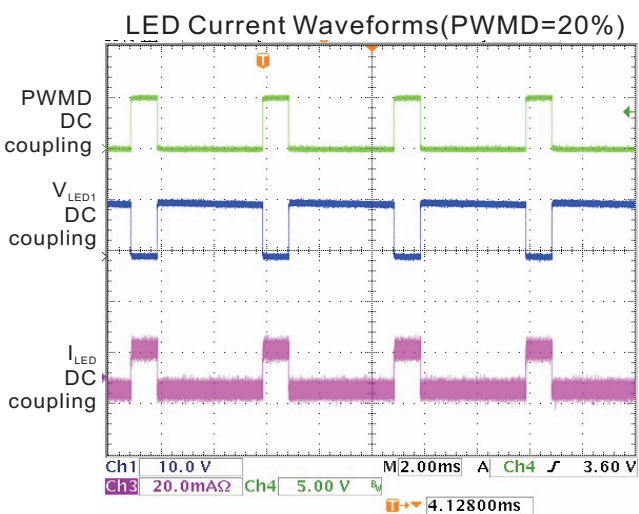
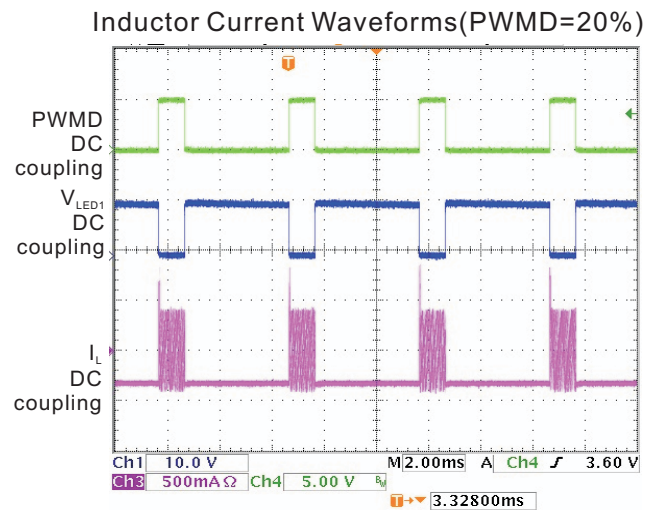
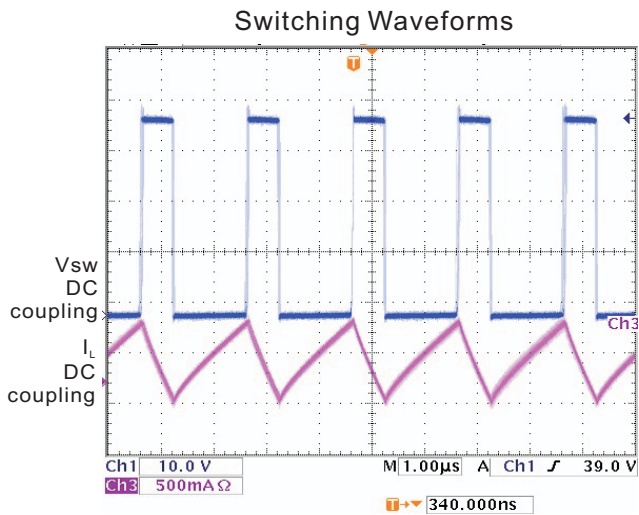
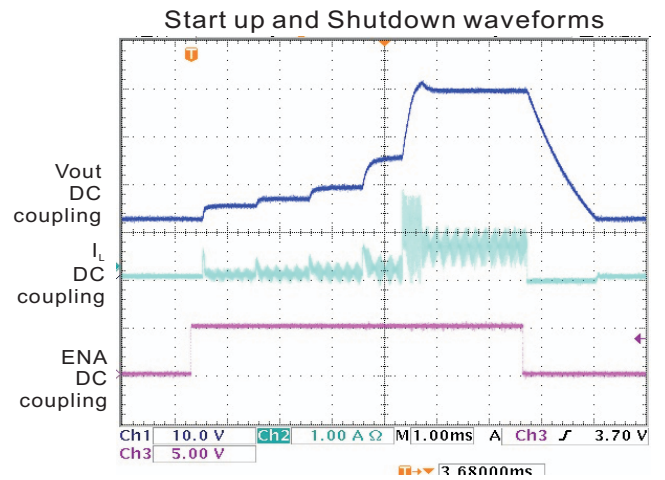
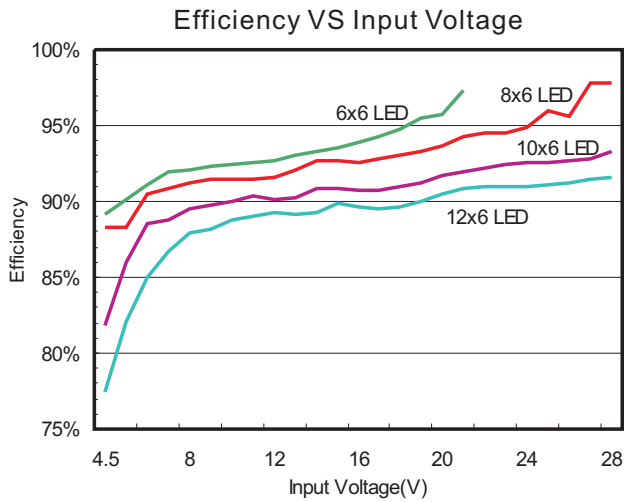



PAM2845

40V High Power Boost Converter with 6 Channel Constant Current Source

Typical Performance Characteristic

$T_A=25^{\circ}\text{C}$, $V_{IN}=ENA=12\text{V}$, $L=22\mu\text{H}$, $R_{set}=10\text{k}\Omega$, unless otherwise noted.

LED Current Waveforms(PWMD=50%)

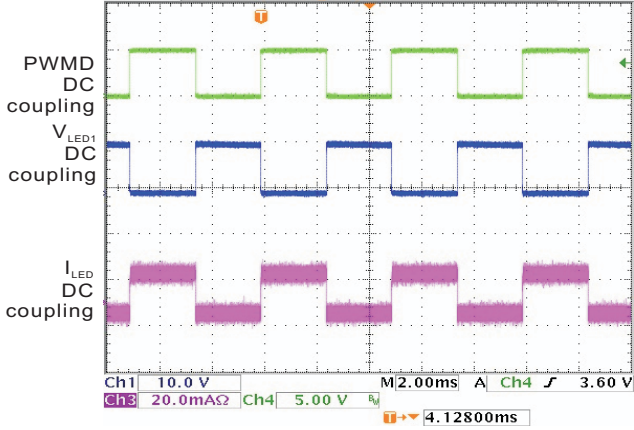

Inductor Current Waveforms(PWMD=80%)

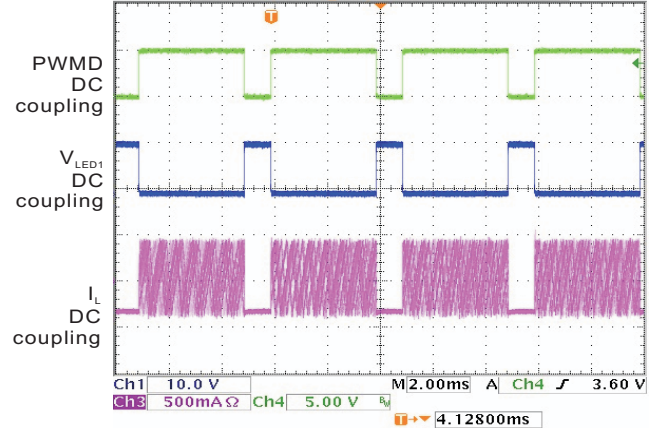

LED Current Waveforms(PWMD=80%)

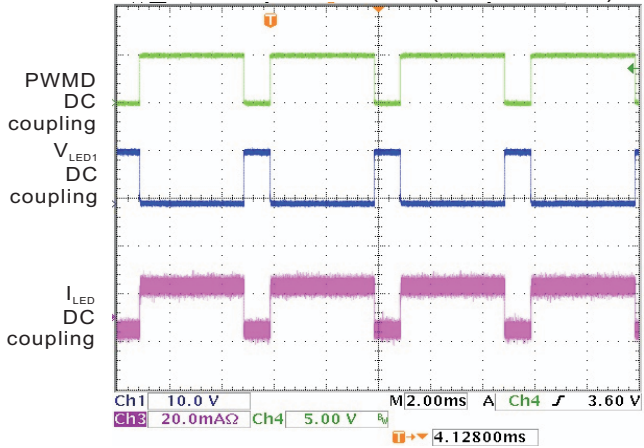

Startup Waveforms

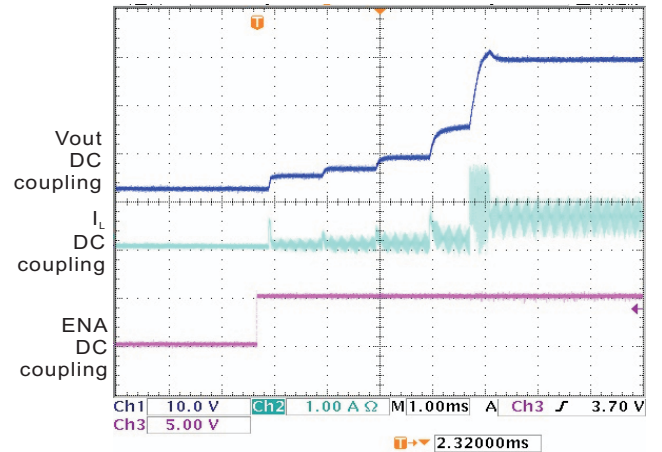

Application Information

Inductor Selection

The inductance, peak current rating, series resistance, and physical size should all be considered when selecting an inductor. These factors affect the converter's operating mode, efficiency, maximum output load capability, transient response time, output voltage ripple, and cost.

The maximum output current, input voltage, output voltage, and switching frequency determine the inductor value. Very high inductance minimizes the current ripple, and therefore reduces the peak current, which decreases core losses in the inductor and I^2R losses in the entire power path. However, large inductor values also require more energy storage and more turns of wire, which increases physical size and I^2R copper losses in the inductor. Low inductor values decrease the physical size, but increase the current ripple and peak current. Finding the best inductor involves the compromises among circuit efficiency, inductor size, and cost.

When choosing an inductor, the first step is to determine the operating mode: continuous conduction mode (CCM) or discontinuous conduction mode (DCM). When CCM mode is chosen, the ripple current and the peak current of the inductor can be minimized. If a small-size inductor is required, DCM mode can be chosen. In DCM mode, the inductor value and size can be minimized but the inductor ripple current and peak current are higher than those in CCM.

Capacitor Selection

An input capacitor is required to reduce the input ripple and noise for proper operation of the PAM2845. For good input decoupling, Low ESR

(equivalent series resistance) capacitors should be used at the input. At least 2.2uF input capacitor is recommended for most applications. A minimum output capacitor value of 10uF is recommended under normal operating conditions, while a 22uF or higher capacitor may be required for higher power LED current. A reasonable value of the output capacitor depends on the LED current. The total output voltage ripple has two components: the capacitive ripple caused by the charging and discharging on the output capacitor, and the ohmic ripple due to the capacitor's equivalent series resistance. The ESR of the output capacitor is the important parameter to determine the output voltage ripple of the converter, so low ESR capacitors should be used at the output to reduce the output voltage ripple. The voltage rating and temperature characteristics of the output capacitor must also be considered. So a value of 10uF, voltage rating(50V) capacitor is chosen.

Diode Selection

PAM2845 is high switching frequency converter, which demands high speed rectifier. It's indispensable to use a Schottky diode rated at 2A, 60V with the PAM2845. Using a Schottky diode with a lower forward voltage drop is better to improve the power LED efficiency, and its voltage rating should be greater than the output voltage.

Methods for Setting LED Current

There are three methods for setting and adjusting the LED current outlined here. The methods are:

- 1) RSET only
- 2) PWM Input at PWMD
- 3) PWM Input at ENA

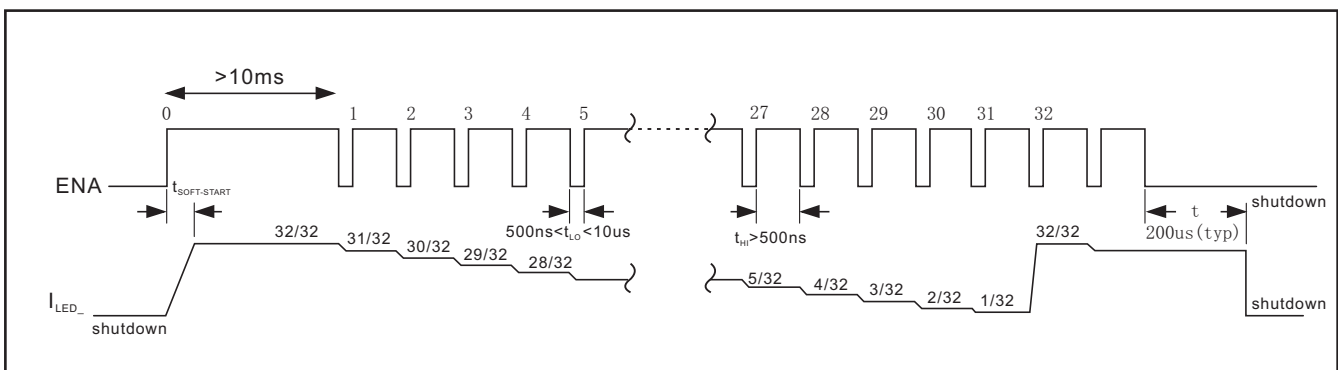

Figure 1

Method 1: LED Current Setting with External Resistor R_{ISET}

The most basic means of setting the LED current is connecting a resistor between R_{ISET} and GND. The LED current is decided by I_{SET} Resistor.

$$I_{LED} = 228 / R_{ISET}$$

Method 2: LED Current Setting Using PWM Signal to PWMD Pin

This circuit uses resistor R_{ISET} to set the on state current and the average LED current, then proportional to the percentage of on-time when the PWMD pin is logic low. Average LED current is approximately equal to:

$$I = (t_{on} * I) / (t_{on} + t_{off})$$

Also, the recommended PWM frequency is between 100Hz and 1kHz. Frequency <100Hz can cause the LEDs to blink visibly.

Method 3: LED Current Setting with single wire logic to ENA Pin

When the LEDs are enabled by high level, the LED current initially goes to I_{LED} . Dimming is done by pulsing ENA low (500ns to 10µs pulse width). Each pulse reduces the LED current by 1/32, so after one pulse the LED current is $31/32 * I_{LED}$. The 32th pulse sets the LED current back to I_{LED} . Figure 1 shows a timing diagram for EN.

Setting the Output Voltage

The FB pin is connected to the center tap of a resistive voltage divider ($R1$ and $R2$ in Figure 1) from the high-voltage output.

$$V_{OUT} = V_{FB} (1 + R2/R1)$$

The recommend procedure is to choose $R2=300k\Omega$ and $R1=9.2k\Omega$ to set $V_{OUT MAX}=40V$.

Generally the V_{out} must be higher than total LED voltage. For 10-LED application, $R1=9.1k\Omega$, $R2=270k\Omega$, $V_{out}=36.8V$, higher than $V_{LED}=33V$.

One or more of the LED1-6 pins could be floating if not used because the PAM2845 uses external resistor to set the output voltage. One or more LEDx pins floating is just like change of output loadings.

LED Short Protection

The PAM2845 uses LED FB function to protect devices when one or more LED(s) is/are shorted.

$$V_{LED} = V_{OUT} - V_f N$$

Normally V_{LED} is around 0.4V and V_{OUT} is decided by LED numbers. When one or more LED(s) is/are shorted, the PAM2845 will clamp V_{OUT} to make sure all LED pins' voltage is less than 5V. With this function V_{OUT} will be clamped at $(5V + V_f N_{MIN})$.

Note:

V_{LED} : LED pin voltage

V_{OUT} : Output voltage

V_f : LED forward voltage

N_{MIN} : The minimum LED numbers among all strings.

PCB Layout Guidelines

Careful PCB layout is important for proper operation. Use the following guidelines for good PCB layout:

- 1) Minimize the area of the high current switching loop of the rectifier diode and output capacitor to avoid excessive switching noise.
- 2) Connect high-current input and output components with short and wide connections. The high-current input loop goes from the positive terminal of the input capacitor to the inductor, to the SW pin. The high-current output loop is from the positive terminal of the input capacitor through the inductor, rectifier diode, and positive terminal of the output capacitors, reconnecting between the output capacitor and input capacitor ground terminals. Avoid using vias in the high-current paths. If vias are unavoidable, use multiple vias in parallel to reduce resistance and inductance.
- 3) Create a ground island (PGND) consisting of the input and output capacitor ground and PGND pin. Connect all these together with short, wide traces or a small ground plane. Maximizing the width of the power ground traces improves efficiency and reduces output-voltage ripple and

noise spikes. Create an analog ground island (GND) consisting of the output voltage detection-divider ground connection, the I_{SET} resistor connections, VCC-5V and VCC-driver capacitor connections, and the device's exposed backside pad. Connect the GND and PGND islands by connecting the GND pins directly to the exposed backside pad. Make sure no other connections between these separate ground planes.

- 4) Place the output voltage setting-divider resistors as close to the OVP pin as possible. The divider's center trace should be kept short. Avoid running the sensing traces near SW Pin.

- 5) Place the VIN pin bypass capacitor as close to the device as possible. The ground connection of the VIN bypass capacitor should be connected directly to GND pins with a wide trace.

- 6) Minimize the size of the SW node while keeping it wide and short. Keep the SW node away from the feedback node and ground. If possible, avoid running the SW node from one side of the PCB to the other.

- 7) Refer to the PAM2845 Evaluation board for an example of proper board layout.

PAM2845 Evaluation Board

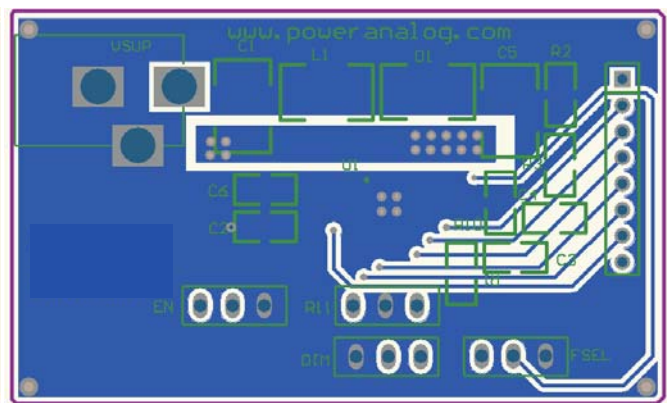
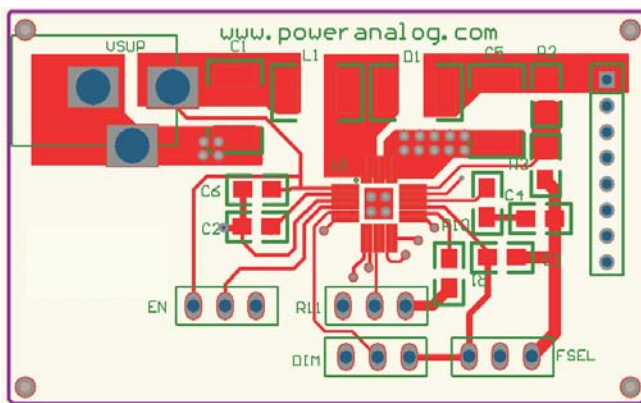



PAM2845

40V High Power Boost Convertor
with 6 Channel Constant Current Source

Ordering Information

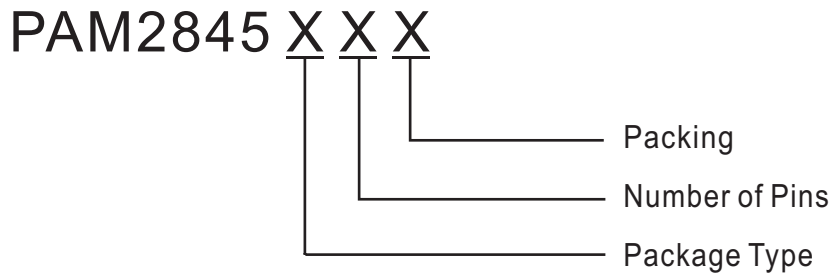

Part Number	Package Type	MOQ/Packing
PAM2845KHR	QFN 4mmx4mm	3,000 Unites /Tape &Reel

Outline Dimensions

QFN 4mmx4mm

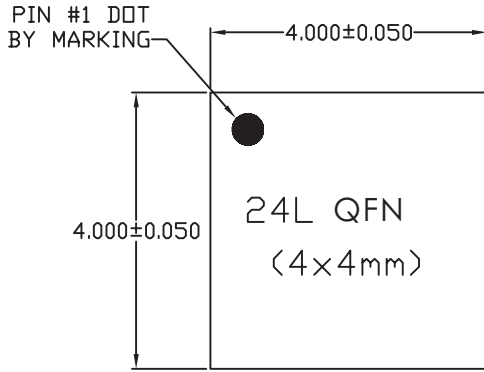

TOP VIEW

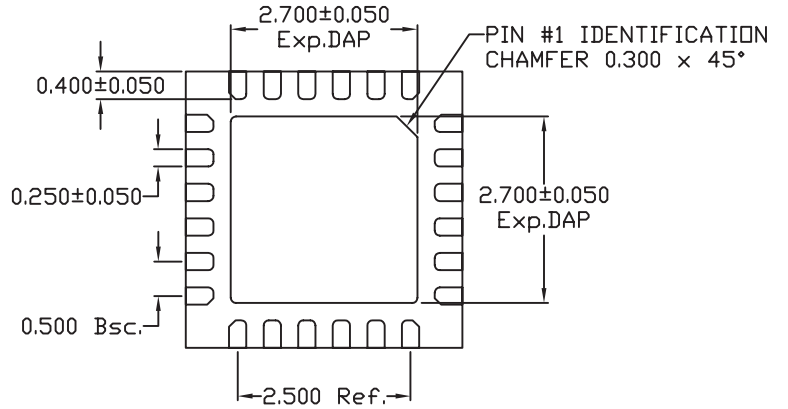

BOTTOM VIEW

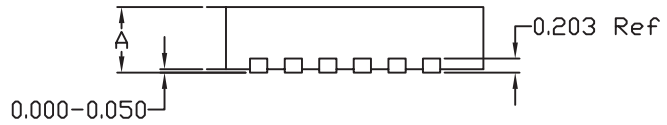

SIDE VIEW

A	MAX.	0.800
	NOM.	0.750
	MIN.	0.700

Note: all dimensions are in millimeters.