

FEATURES

- High-speed access time: 15 and 20 ns
- CMOS low power operation
- TTL compatible interface levels
- Single 5V ± 10% power supply
- Fully static operation: no clock or refresh required
- Three state outputs
- Industrial temperature available
- Available in 44-pin SOJ package and 44-pin TSOP (Type II)

DESCRIPTION

The *ISSI* IS64C6416 is a high-speed, 1,048,576-bit static RAM organized as 65,536 words by 16 bits. It is fabricated using *ISSI*'s high-performance CMOS technology. This highly reliable process coupled with innovative circuit design techniques, yields access times as fast as 10 ns with low power consumption.

When \overline{CE} is HIGH (deselected), the device assumes a standby mode at which the power dissipation can be reduced down with CMOS input levels.

Easy memory expansion is provided by using Chip Enable and Output Enable inputs, \overline{CE} and \overline{OE} . The active LOW Write Enable (\overline{WE}) controls both writing and reading of the memory. A data byte allows Upper Byte (\overline{UB}) and Lower Byte (\overline{LB}) access.

The IS64C6416 is packaged in the JEDEC standard 44-pin 400-mil SOJ and 44-pin TSOP (Type II).

FUNCTIONAL BLOCK DIAGRAM

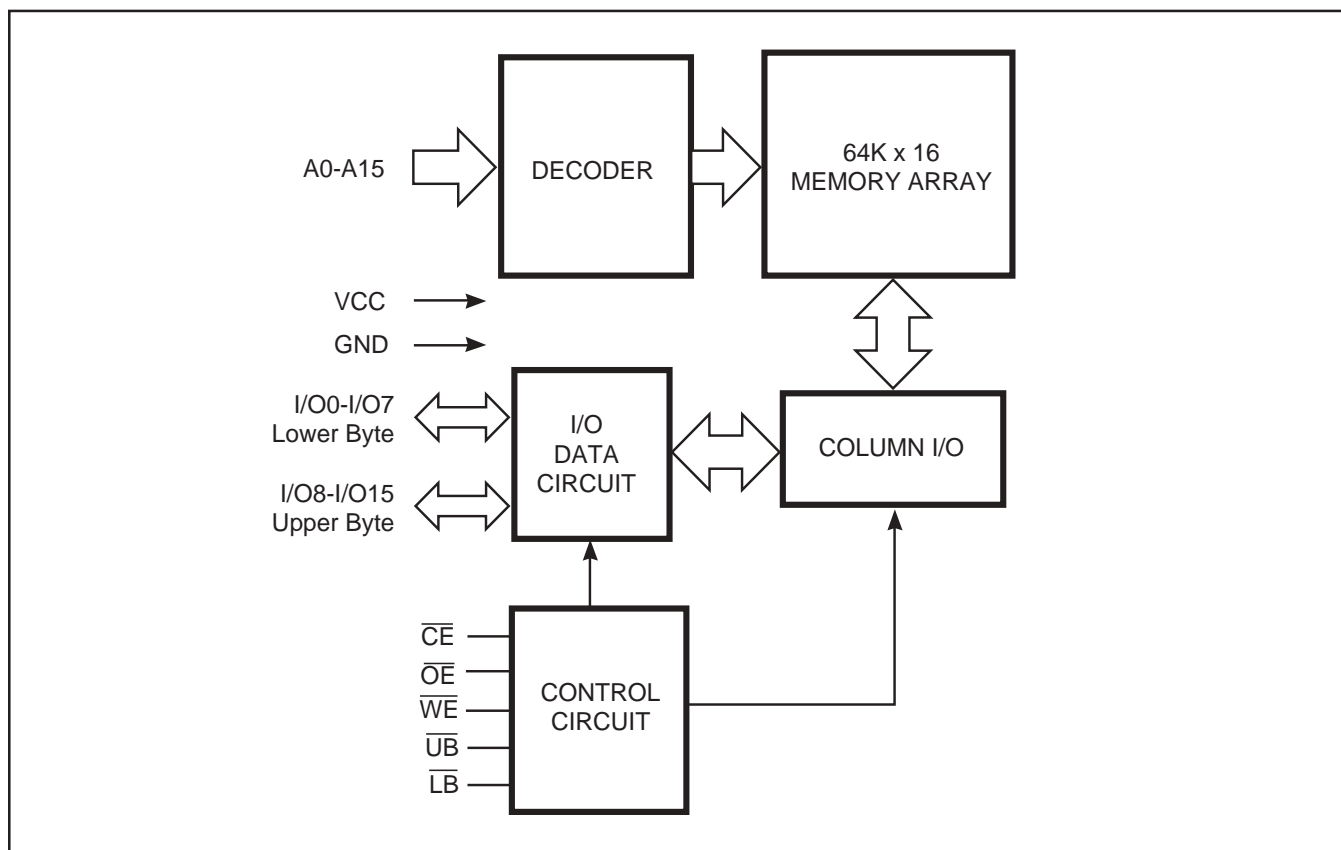

Copyright © 2003 Integrated Silicon Solution, Inc. All rights reserved. ISSI reserves the right to make changes to this specification and its products at any time without notice. ISSI assumes no liability arising out of the application or use of any information, products or services described herein. Customers are advised to obtain the latest version of this device specification before relying on any published information and before placing orders for products.

PIN CONFIGURATIONS

44-Pin SOJ

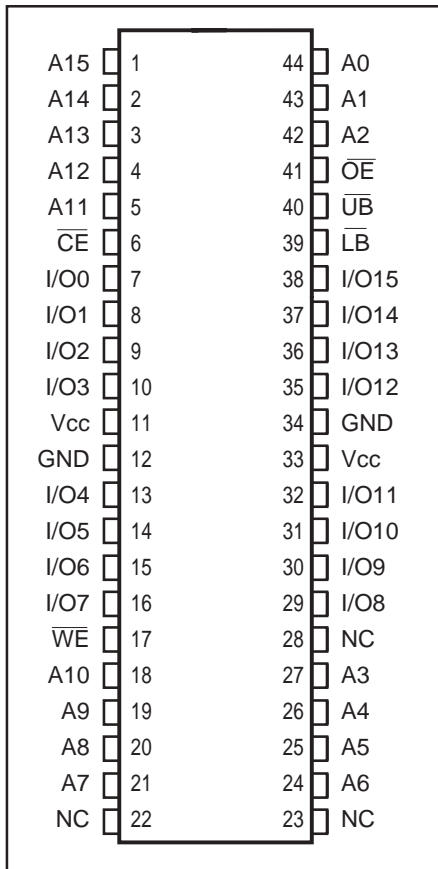

44-Pin TSOP (Type II)

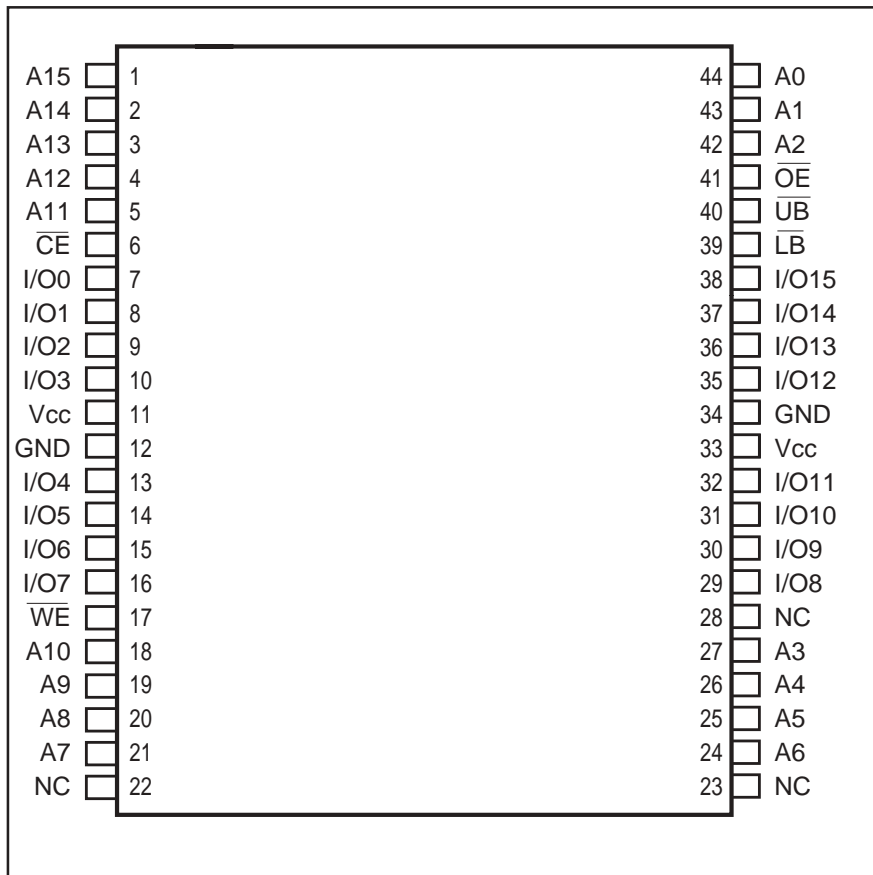

PIN DESCRIPTIONS

A0-A15	Address Inputs
I/O0-I/O15	Data Inputs/Outputs
\overline{CE}	Chip Enable Input
\overline{OE}	Output Enable Input
\overline{WE}	Write Enable Input
\overline{LB}	Lower-byte Control (I/O0-I/O7)
\overline{UB}	Upper-byte Control (I/O8-I/O15)
NC	No Connection
Vcc	Power
GND	Ground

TRUTH TABLE

Mode	I/O PIN					I/O PIN		Vcc Current
	\overline{WE}	\overline{CE}	\overline{OE}	\overline{LB}	\overline{UB}	I/O0-I/O7	I/O8-I/O15	
Not Selected	X	H	X	X	X	High-Z	High-Z	I _{SB1} , I _{SB2}
Output Disabled	H	L	H	X	X	High-Z	High-Z	I _{CC1} , I _{CC2}
	X	L	X	H	H	High-Z	High-Z	
Read	H	L	L	L	H	D _{OUT}	High-Z	I _{CC1} , I _{CC2}
	H	L	L	H	L	High-Z	D _{OUT}	
	H	L	L	L	L	D _{OUT}	D _{OUT}	
Write	L	L	X	L	H	D _{IN}	High-Z	I _{CC1} , I _{CC2}
	L	L	X	H	L	High-Z	D _{IN}	
	L	L	X	L	L	D _{IN}	D _{IN}	

ABSOLUTE MAXIMUM RATINGS⁽¹⁾

Symbol	Parameter	Value	Unit
V _{TERM}	Terminal Voltage with Respect to GND	-0.5 to +7.0	V
T _{STG}	Storage Temperature	-65 to +150	°C
P _T	Power Dissipation	1.5	W
I _{OUT}	DC Output Current (LOW)	20	mA

Note:

1. Stress greater than those listed under ABSOLUTE MAXIMUM RATINGS may cause permanent damage to the device. This is a stress rating only and functional operation of the device at these or any other conditions above those indicated in the operational sections of this specification is not implied. Exposure to absolute maximum rating conditions for extended periods may affect reliability.

OPERATING RANGE

Options	Ambient Temperature	Vcc
A1	-40°C to +85°C	5V ± 10%
A2	-40°C to +105°C	5V ± 10%
A3	-40°C to +125°C	5V ± 10%

DC ELECTRICAL CHARACTERISTICS (Over Operating Range)

Symbol	Parameter	Test Conditions	Min.	Max.	Unit
V _{OH}	Output HIGH Voltage	V _{CC} = Min., I _{OH} = -4.0 mA	2.4	—	V
V _{OL}	Output LOW Voltage	V _{CC} = Min., I _{OL} = 8.0 mA	—	0.4	V
V _{IH}	Input HIGH Voltage		2.5	V _{CC} + 0.5	V
V _{IL}	Input LOW Voltage ⁽¹⁾		-0.5	0.8	V
I _{LI}	Input Leakage	GND ≤ V _{IN} ≤ V _{CC}	-2	2	μA
I _{LO}	Output Leakage	GND ≤ V _{OUT} ≤ V _{CC} , Outputs Disabled	-2	2	μA

Notes:

1. V_{IL} (min.) = -3.0V for pulse width less than 10 ns.

POWER SUPPLY CHARACTERISTICS⁽¹⁾ (Over Operating Range)

Symbol	Parameter	Test Conditions	-15		-20		Unit	
			Min.	Max.	Min.	Max.		
I _{CC}	V _{CC} Dynamic Operating Supply Current	V _{CC} = Max., I _{OUT} = 0 mA, f = MAX	A1	—	250	—	—	mA
			A2	—	—	—	255	
			A3	—	—	—	260	
I _{SB1}	TTL Standby Current (TTL Inputs)	V _{CC} = Max., V _{IN} = V _{IH} or V _{IL} $\overline{CE} \geq V_{IH}$, f = max	A1	—	50	—	—	mA
			A2	—	—	—	55	
			A3	—	—	—	55	
I _{SB2}	CMOS Standby Current (CMOS Inputs)	V _{CC} = Max., $\overline{CE} \geq V_{CC} - 0.2V$, V _{IN} ≥ V _{CC} - 0.2V, or V _{IN} ≤ 0.2V, f = 0	A1	—	5	—	—	mA
			A2	—	—	—	10	
			A3	—	—	—	15	

Note:

1. At f = f_{MAX}, address and data inputs are cycling at the maximum frequency, f = 0 means no input lines change.

CAPACITANCE⁽¹⁾

Symbol	Parameter	Conditions	Max.	Unit
C _{IN}	Input Capacitance	V _{IN} = 0V	6	pF
C _{OUT}	Input/Output Capacitance	V _{OUT} = 0V	8	pF

Note:

1. Tested initially and after any design or process changes that may affect these parameters.

AC TEST CONDITIONS

Parameter	Unit
Input Pulse Level	0V to 3.0V
Input Rise and Fall Times	3 ns
Input and Output Timing and Reference Level	1.5V
Output Load	See Figures 1 and 2

AC TEST LOADS

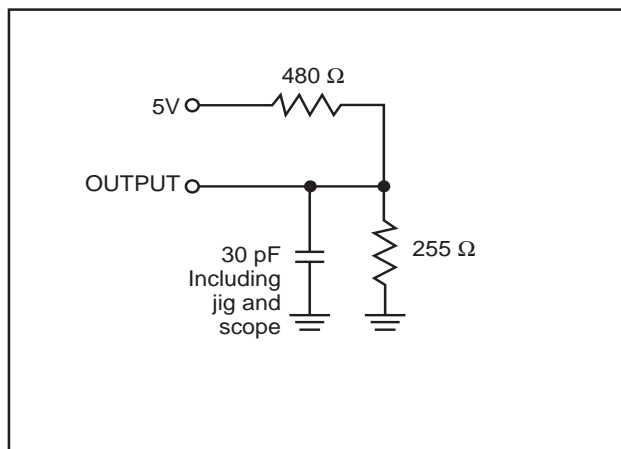

Figure 1

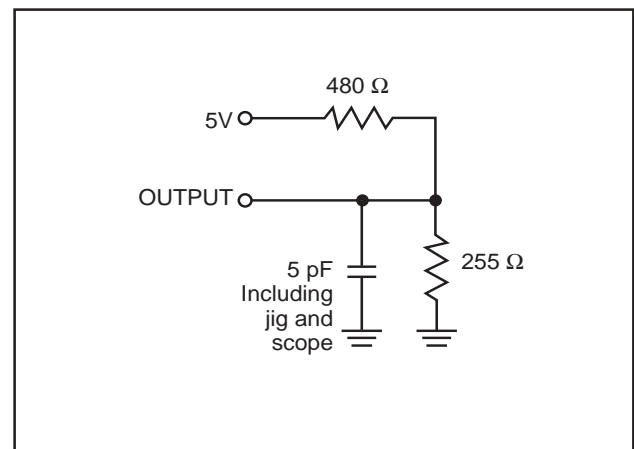

Figure 1

READ CYCLE SWITCHING CHARACTERISTICS⁽¹⁾ (Over Operating Range)

Symbol	Parameter	-15		-20		Unit
		Min.	Max.	Min.	Max.	
t _{RC}	Read Cycle Time	15	—	20	—	ns
t _{AA}	Address Access Time	—	15	—	20	ns
t _{OH}	Output Hold Time	3	—	3	—	ns
t _{ACE}	\overline{CE} Access Time	—	15	—	20	ns
t _{DOE}	\overline{OE} Access Time	—	7	—	9	ns
t _{HZOE⁽²⁾}	\overline{OE} to High-Z Output	0	6	0	8	ns
t _{LZOE⁽²⁾}	\overline{OE} to Low-Z Output	0	—	0	—	ns
t _{HZCE⁽²⁾}	\overline{CE} to High-Z Output	0	6	0	8	ns
t _{LZCE⁽²⁾}	\overline{CE} to Low-Z Output	3	—	3	—	ns
t _{BA}	\overline{LB} , \overline{UB} Access Time	—	7	—	9	ns
t _{HZB}	\overline{LB} , \overline{UB} to High-Z Output	0	6	0	8	ns
t _{LZB}	\overline{LB} , \overline{UB} to Low-Z Output	0	—	0	—	ns

Notes:

1. Test conditions assume signal transition times of 3 ns or less, timing reference levels of 1.5V, input pulse levels of 0 to 3.0V and output loading specified in Figure 1.
2. Tested with the load in Figure 2. Transition is measured ± 500 mV from steady-state voltage. Not 100% tested.
3. Not 100% tested.

AC WAVEFORMS

READ CYCLE NO. 1^(1,2) (Address Controlled) ($\overline{CE} = \overline{OE} = V_{IL}$, \overline{UB} or $\overline{LB} = V_{IL}$)

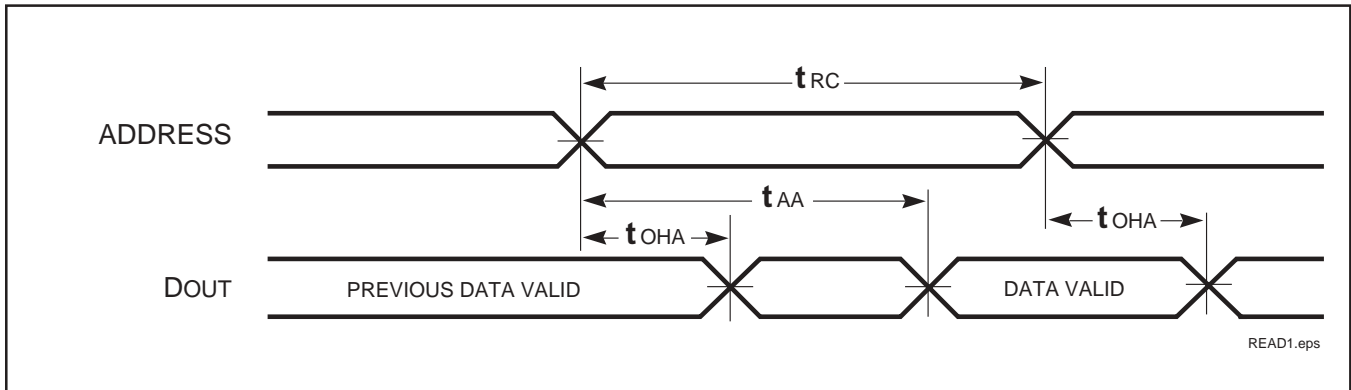

READ CYCLE NO. 2^(1,3)

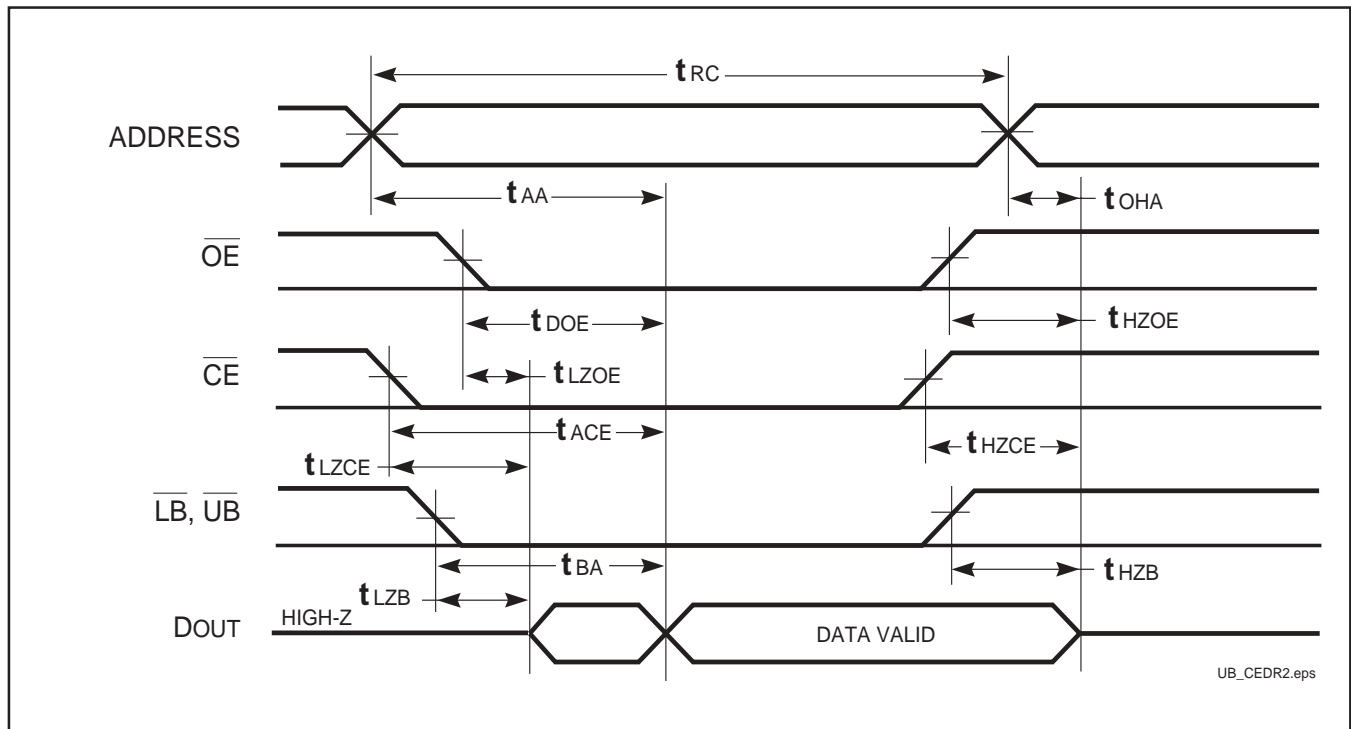

Notes:

1. \overline{WE} is HIGH for a Read Cycle.
2. The device is continuously selected. \overline{OE} , \overline{CE} , \overline{UB} , or $\overline{LB} = V_{IL}$.
3. Address is valid prior to or coincident with \overline{CE} LOW transition.

WRITE CYCLE SWITCHING CHARACTERISTICS^(1,3) (Over Operating Range)

Symbol	Parameter	-15		-20		Unit
		Min.	Max.	Min.	Max.	
t _{WC}	Write Cycle Time	15	—	20	—	ns
t _{SCE}	\overline{CE} to Write End	10	—	12	—	ns
t _{AW}	Address Setup Time to Write End	10	—	12	—	ns
t _{HA}	Address Hold from Write End	0	—	0	—	ns
t _{SA}	Address Setup Time	0	—	0	—	ns
t _{PWB}	\overline{LB} , \overline{UB} Valid to End of Write	10	—	12	—	ns
t _{PWE1}	\overline{WE} Pulse Width (\overline{OE} =High)	10	—	12	—	ns
t _{PWE2}	\overline{WE} Pulse Width (\overline{OE} =Low)	10	—	12	—	ns
t _{SD}	Data Setup to Write End	7	—	9	—	ns
t _{HD}	Data Hold from Write End	0	—	0	—	ns
t _{HZWE⁽²⁾}	\overline{WE} LOW to High-Z Output	—	7	—	9	ns
t _{LZWE⁽²⁾}	\overline{WE} HIGH to Low-Z Output	3	—	3	—	ns

Notes:

1. Test conditions assume signal transition times of 3 ns or less, timing reference levels of 1.5V, input pulse levels of 0 to 3.0V and output loading specified in Figure 1.
2. Tested with the load in Figure 2. Transition is measured ± 500 mV from steady-state voltage. Not 100% tested.
3. The internal write time is defined by the overlap of \overline{CE} LOW and \overline{UB} or \overline{LB} , and \overline{WE} LOW. All signals must be in valid states to initiate a Write, but any one can go inactive to terminate the Write. The Data Input Setup and Hold timing are referenced to the rising or falling edge of the signal that terminates the write.

AC WAVEFORMS

WRITE CYCLE NO. 1 (\overline{WE} Controlled)^(1,2)

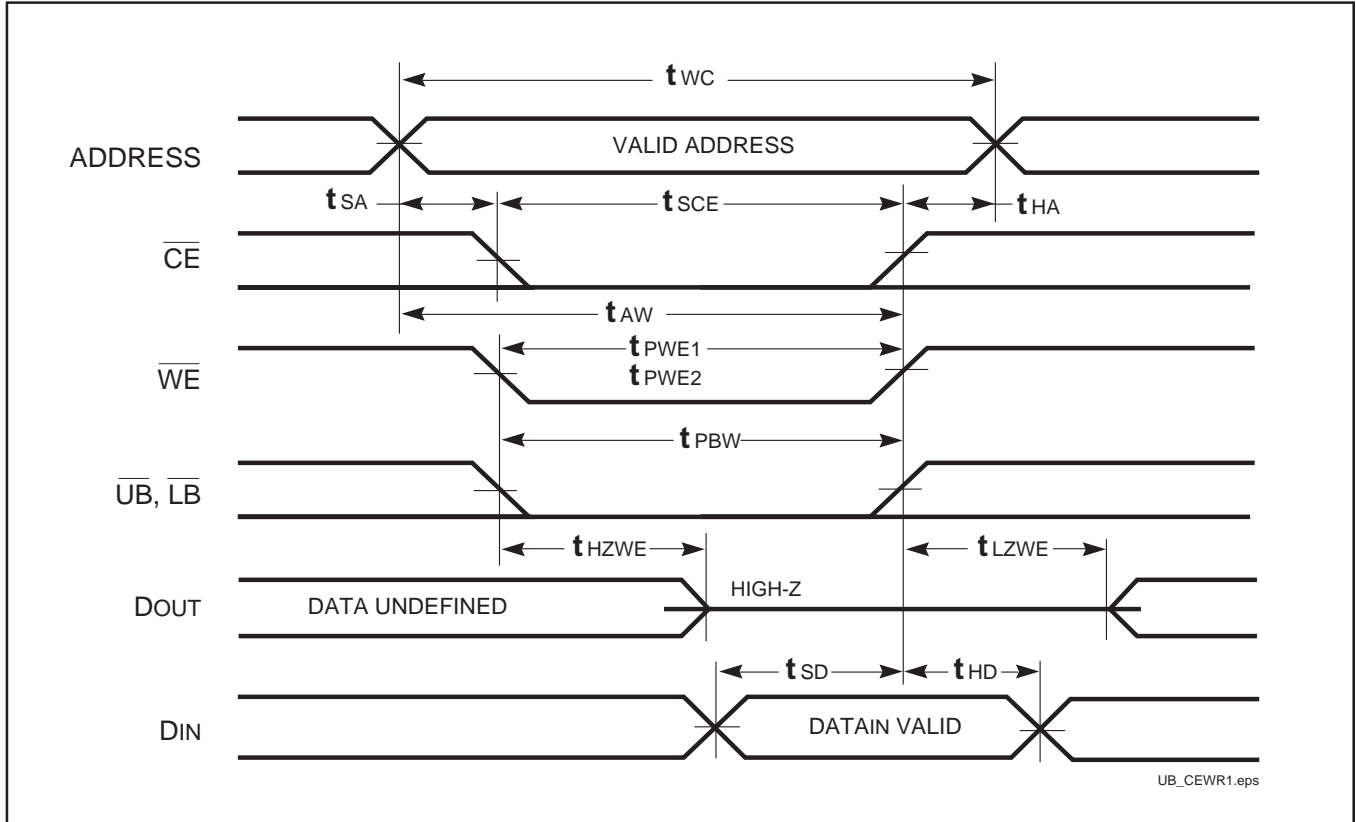

Notes:

1. WRITE is an internally generated signal asserted during an overlap of the LOW states on the \overline{CE} and \overline{WE} inputs and at least one of the \overline{LB} and \overline{UB} inputs being in the LOW state.
2. $WRITE = (\overline{CE}) [(\overline{LB}) = (\overline{UB})] (\overline{WE})$.

WRITE CYCLE NO. 2 (\overline{OE} is HIGH During Write Cycle) ^(1,2)

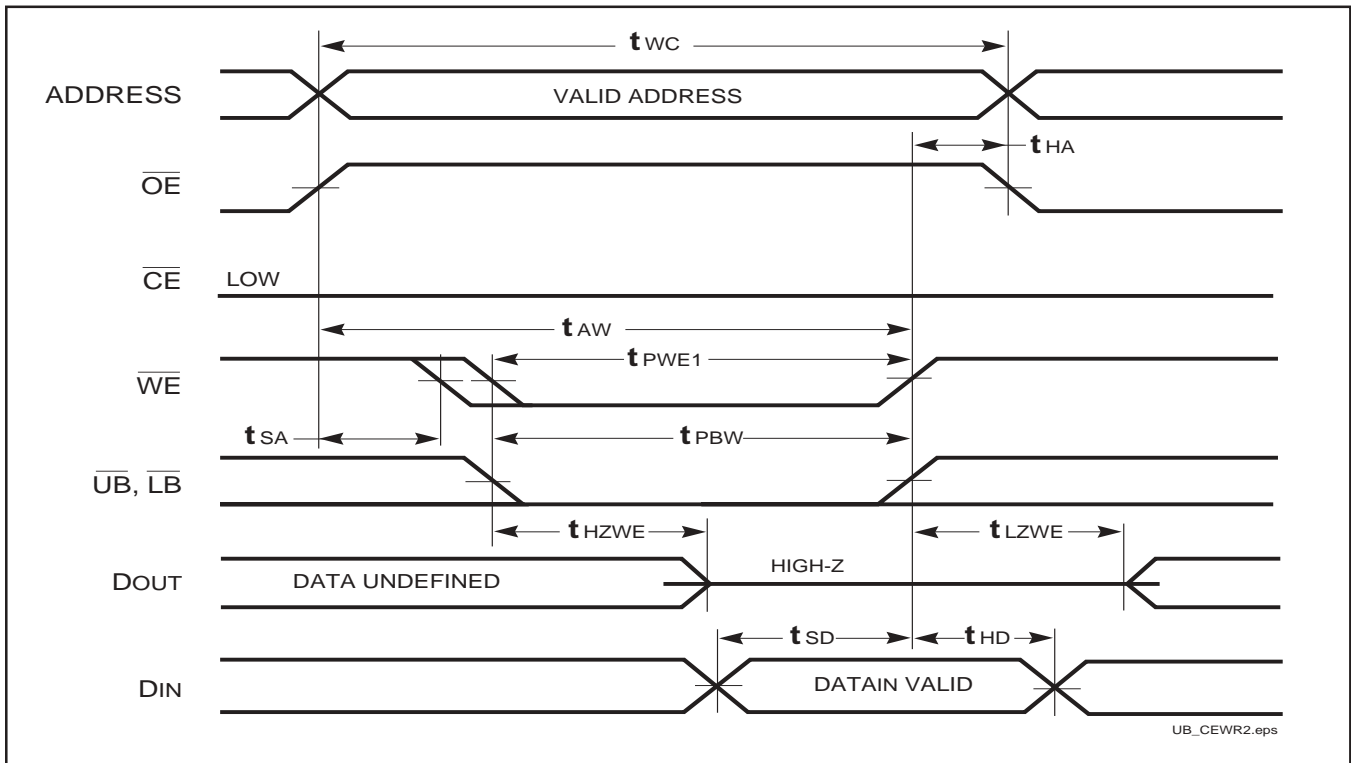

WRITE CYCLE NO. 3 (\overline{OE} is LOW During Write Cycle) ⁽¹⁾

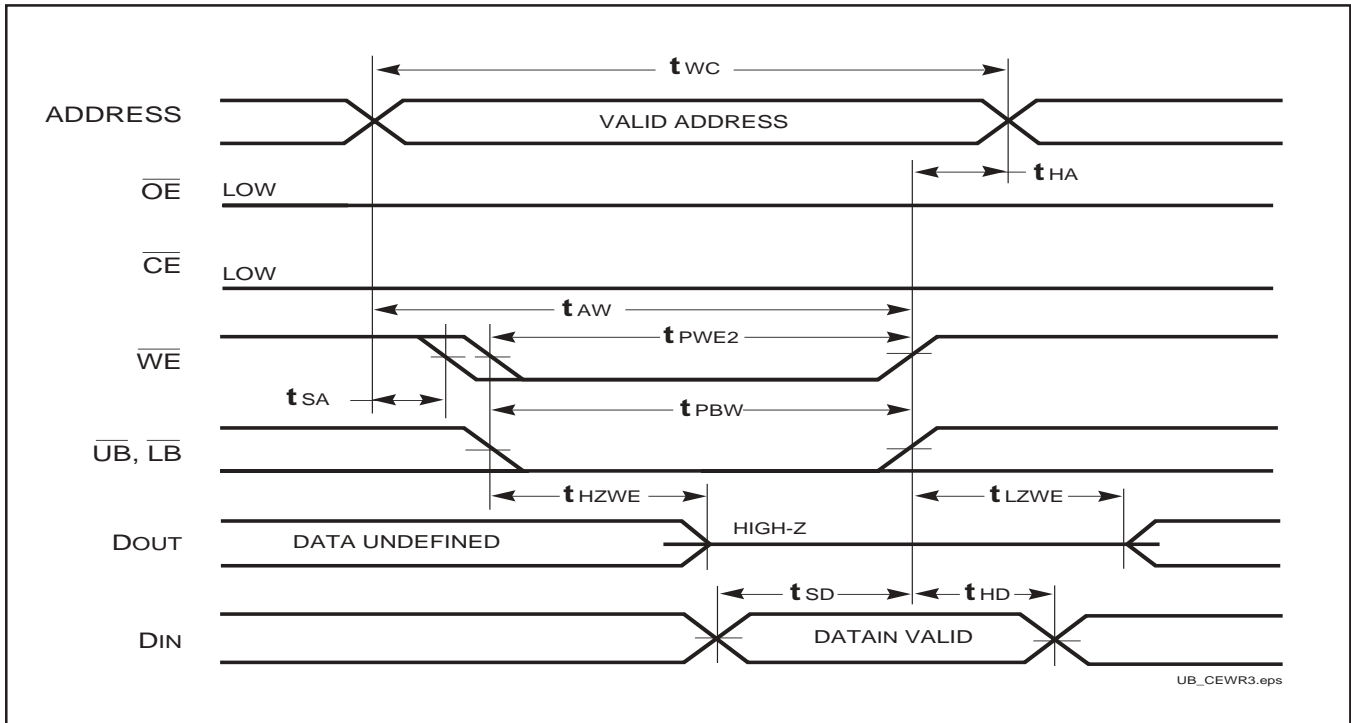

Notes:

1. The internal write time is defined by the overlap of \overline{CE} LOW and \overline{WE} LOW. All signals must be in valid states to initiate a Write, but any one can go inactive to terminate the Write. The Data Input Setup and Hold timing are referenced to the rising or falling edge of the signal that terminates the Write.
2. I/O will assume the High-Z state if $\overline{OE} \geq V_{IH}$.

WRITE CYCLE NO. 4 ($\overline{UB}/\overline{LB}$ Back to Back Write)

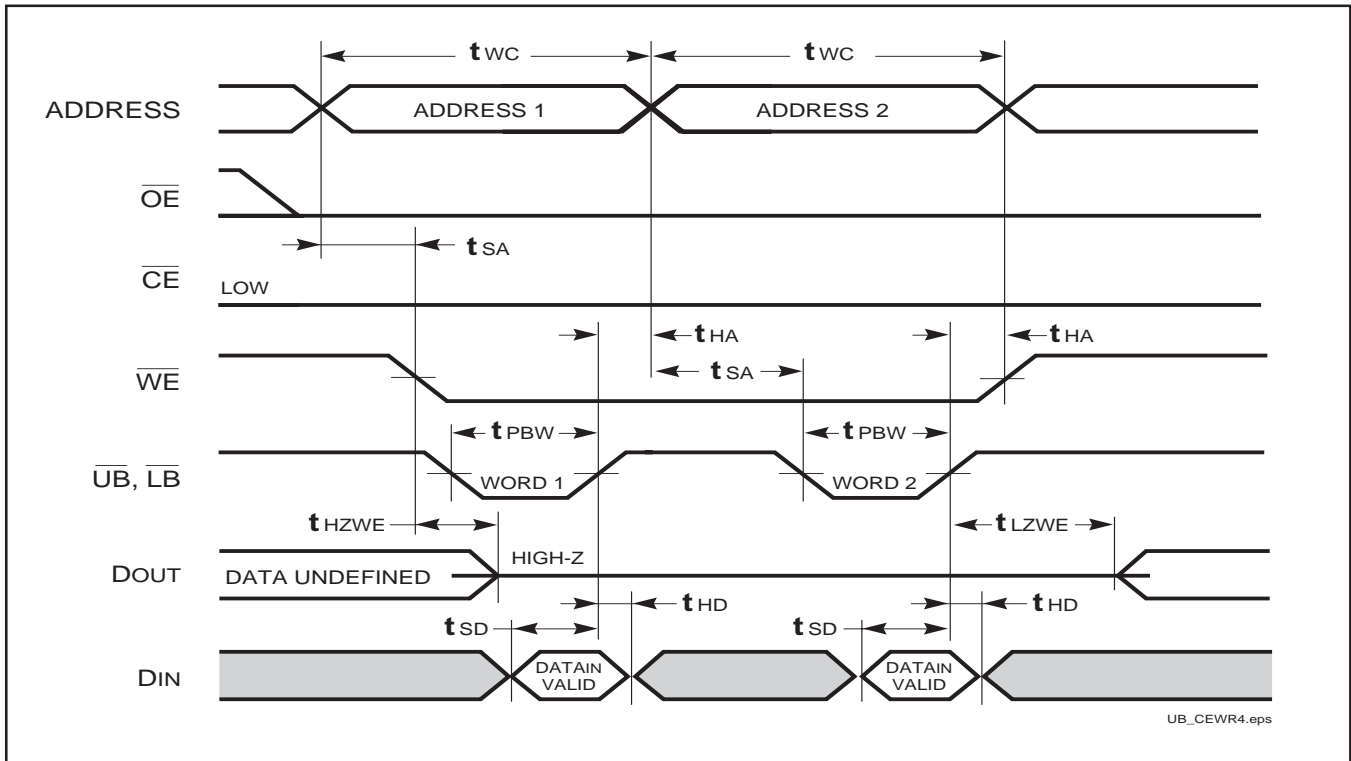

ORDERING INFORMATION**Temperature Range (A1): –40°C to +85°C**

Speed (ns)	Order Part No.	Package
15	IS64C6416-15TA1	44-pin TSOP (Type II)
	IS64C6416-15KA1	44-pin 400-mil Plastic SOJ

Temperature Range (A2): –40°C to +105°C

Speed (ns)	Order Part No.	Package
20	IS64C6416-20TA2	44-pin TSOP (Type II)
	IS64C6416-20KA2	44-pin 400-mil Plastic SOJ

Temperature Range (A3): –40°C to +125°C

Speed (ns)	Order Part No.	Package
20	IS64C6416-20TA3	44-pin TSOP (Type II)
	IS64C6416-20KA3	44-pin 400-mil Plastic SOJ