

HDM2432L-T

Dimensional Drawing

240 X 320 Dots Graphic (Portrait Mode) White LED Backlight

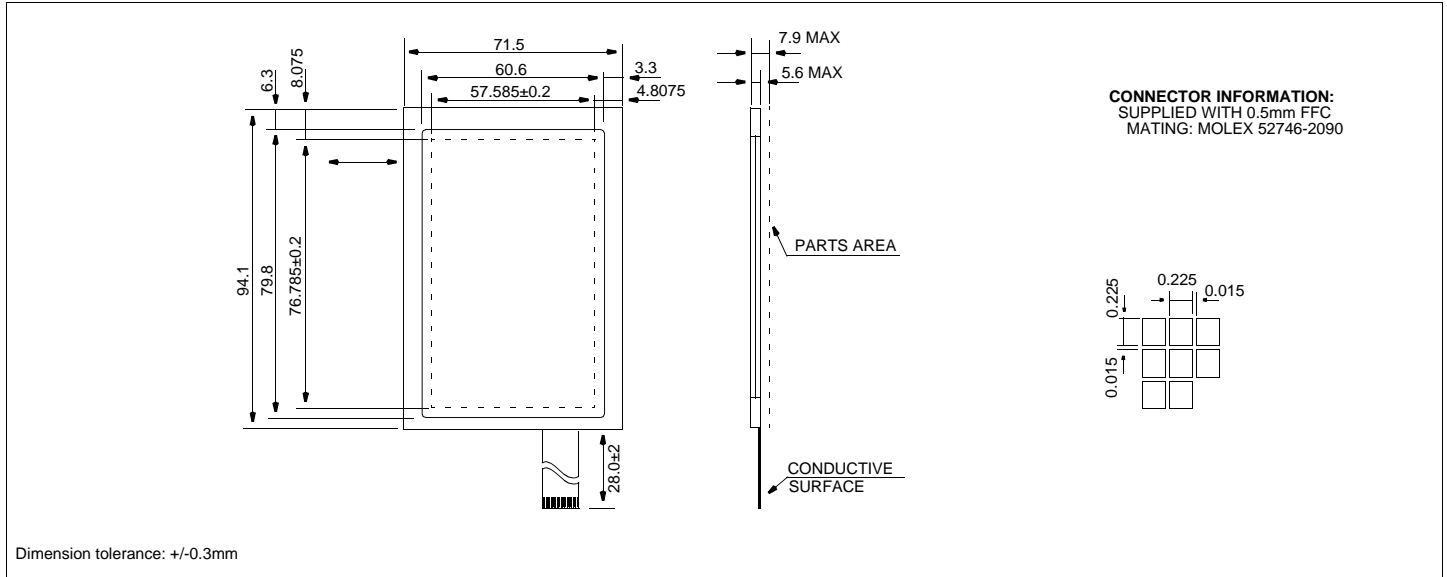

Features

Backlight.....White LED
 Options.....Black and White FSTN
 Extended Temperature
 Bottom Viewing
 Built-in Controller.....None

Physical Data

Module Size.....71.5W x 94.1H x 7.9T mm
 Viewing Area Size.....60.6W x 79.8H mm
 Dot Pitch.....0.24W x 0.24H mm
 Dot Size.....0.225W x 0.225H mm
 Weight.....52g

Absolute Maximum Ratings

PARAMETER	SYMBOL	MIN	MAX	UNIT
SUPPLY VOLTAGE	$V_{DD}-V_{SS}$	-0.3	7.0	V
SUPPLY VOLTAGE FOR LCD	$V_{DD}-V_{EE}$	-0.3	30.0	V
INPUT VOLTAGE	V_{IN}	-0.3	V_{DD}	V
OPERATING TEMPERATURE	T_{OP}	-0	50	°C
STORAGE TEMPERATURE	T_{STG}	-20	70	°C

Power Supply

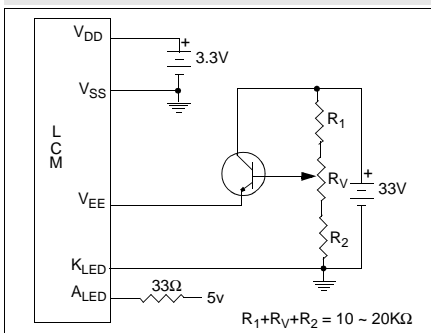

Pin Connections

PIN NO.	SYMBOL	LEVEL	FUNCTION
1	V_{DD}	3.3V	Power supply for logic
2	SGND	-	Shield Ground
3	V_{EE}	-	Power supply for LCD
4	FLM	H/L	First Line Marker
5	DISP ENA	H/L	H = Display ON, L = Display OFF
6	M	H/L	AC signal
7	CL1	H/L	Data Latch clock
8	CL2	H/L	Data shift clock
9	V_{SS}	0V	Ground
10	D0	H/L	Display data
11	D1	H/L	
12	D2	H/L	
13	D3	H/L	Ground
14	V_{SS}	0V	
15	LED +	-	Anode for LED
16	LED-	-	Cathode for LED
17	N/C		No Connection
18	N/C		
19	N/C		
20	N/C		

Electrical Characteristics (VDD=3.3±0.25V 25°C)

PARAMETER	SYM	CONDITION	MIN	TYP	MAX	UNIT
INPUT HIGH VOLTAGE	V_{IH}	-	0.8 V_{DD}	-	V_{DD}	V
INPUT LOW VOLTAGE	V_{IL}	-	0	-	0.2 V_{DD}	V
OUTPUT HIGH VOLTAGE	V_{OH}	$I_{OH}=0.4mA$	$V_{DD}-0.4$	-	-	V
OUTPUT LOW VOLTAGE	V_{OL}	$I_{OL}=0.4mA$	-	-	0.4	V
SUPPLY VOLTAGE	V_{DD}	-	3.0	3.3	3.6	V
	V_{EE}	-	26.4	26.8	27.2	V
LED BACKLIGHT	I_{LED}	$V_{LED}=5V$	-	55	82	mA
BRIGHTNESS	L	$I_{LED}=55mA$	-	8.3	-	NIT
DRIVE METHOD	1/320 DUTY					