

Diode Module with Brake

Diode:1600V / 75A, IGBT:1400A/50A

■ Features

- Compact Package
- P.C. Board Mount Module
- Converter Diode Bridge Dynamic Brake Circuit

■ Applications

- Inverter for Motor Drive
- AC and DC Servo Drive Amplifier
- Uninterruptible Power Supply

■ Maximum ratings and characteristics

● Absolute maximum ratings (Tc=25°C unless without specified)

Item	Symbol	Condition	Rating	Unit	
Converter	Repetitive peak reverse voltage	V _{RRM}	1600	V	
	Non-repetitive peak reverse voltage	V _{RSM}	1760	V	
	Average output current	I _o	50Hz/60Hz sine wave Tc=115°C	75	A
	One cycle surge current	I _{FSM}	From rated load	600	A
	Peak current	I _p	From rated load	1440	A
	Operation junction temperature	T _j		-40 to +125	°C
Brake	Collector-Emitter voltage	V _{GES}	1400	V	
	Gate-Emitter voltage	V _{GES}	±20	V	
	Collector current	I _c	DC	Tc=25°C 50	A
				Tc=75°C 35	
			1ms	Tc=25°C 100 Tc=75°C 70	A
	Collector power dissipation	P _c	1 device	240	W
	Repetitive peak reverse voltage	V _{RRM}		1400	V
	Operation junction temperature	T _j		+150	°C
	Storage junction temperature	T _{sg}	AC : 1 minute	-40 to +125	°C
	Isolation voltage	V _{iso}	M5 screw	3000	V
Mounting screw torque			2.0 to 2.5	N·m	

● Electrical characteristics (Tj=25°C unless otherwise specified)

Item	Symbol	Condition	Min.	Typ.	Max.	Unit	
Co.	Forward voltage	V _{FM}			1.35	V	
	Reverse current	I _{RRM}			15	mA	
Brake	Zero gate voltage Collector current	I _{CES}			1.0	mA	
	Gate-Emitter leakage current	I _{GES}			200	nA	
	Collector-Emitter saturation voltage	V _{CE(sat)}	V _{GE} =15V, I _c =35A		2.4	2.8	V
	Turn-on time	ton	V _{CC} =800V		0.35	1.2	μs
		tr	I _c =35A		0.25	0.6	
	Turn-off time	toff	V _{GE} =±15V		0.45	1.0	
		tf	R _G =33ohm		0.08	0.3	
Reverse current	I _{RRM}				1.0	mA	

● Thermal characteristics

Item	Symbol	Condition	Min.	Typ.	Max.	Unit
Thermal resistance	R _{th(j-c)}	Converter	Per total loss		0.16	°C/W
			Per each device		0.96	
		Brake IGBT (1 device)		0.70		
Thermal Resistance(Case to fine)	R _{th(c-f)}	with thermal compound			0.08	°C/W

Forward Characteristics

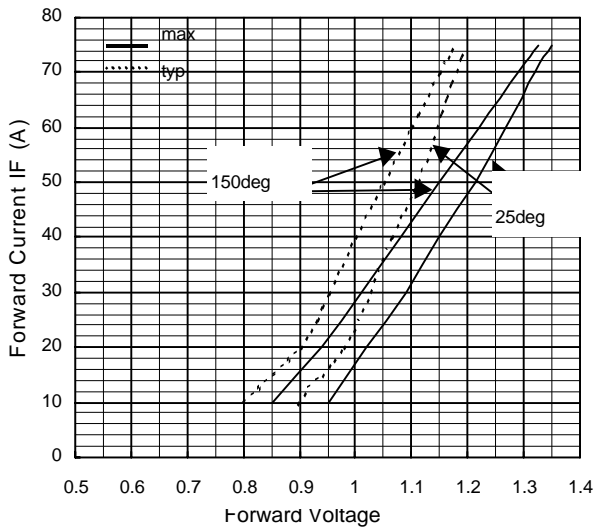

Output Current - Total Loss

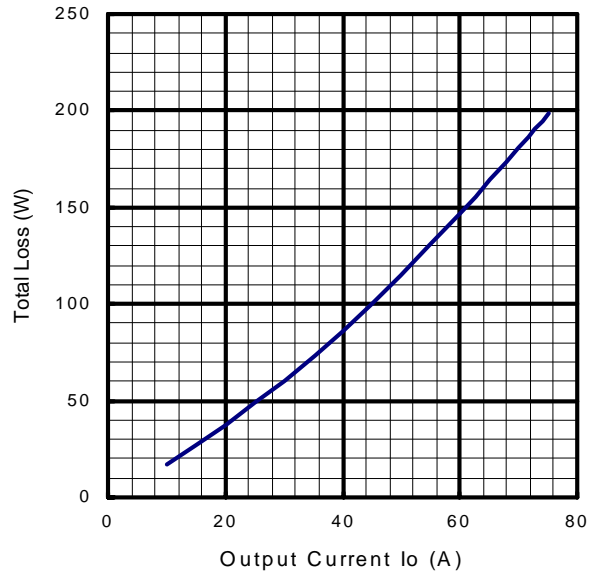

Output Current - Case Temperature

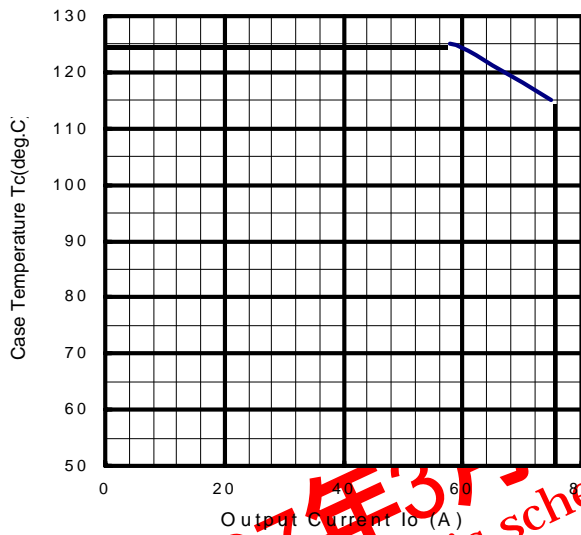

Surge Current

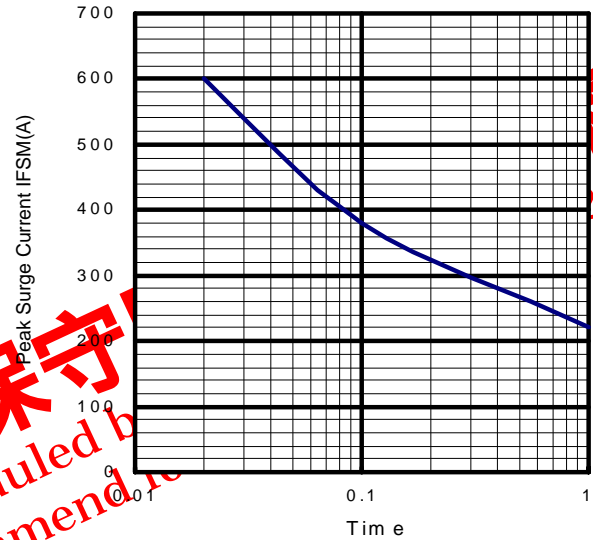

Transient Thermal Impedance

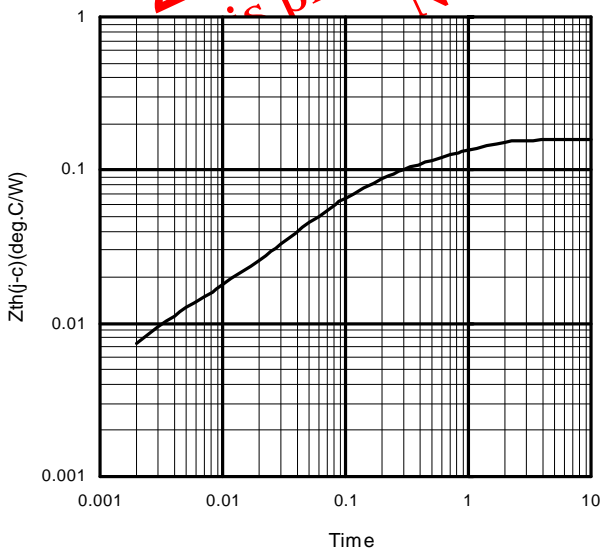

[Brake] Transient Thermal Impedance

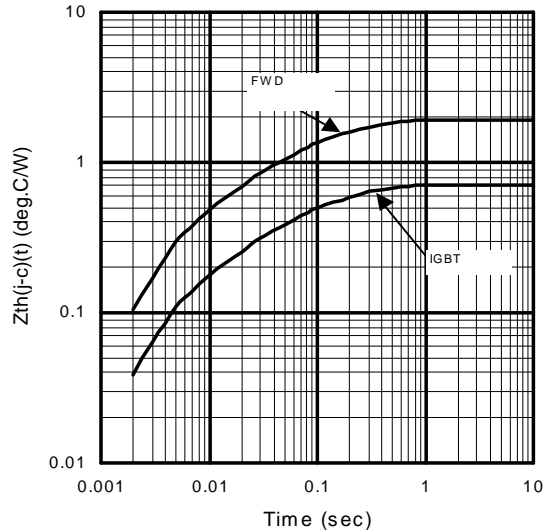

2007年5月 保守
 This product is scheduled for obsolescence
 Not recommended for new designs

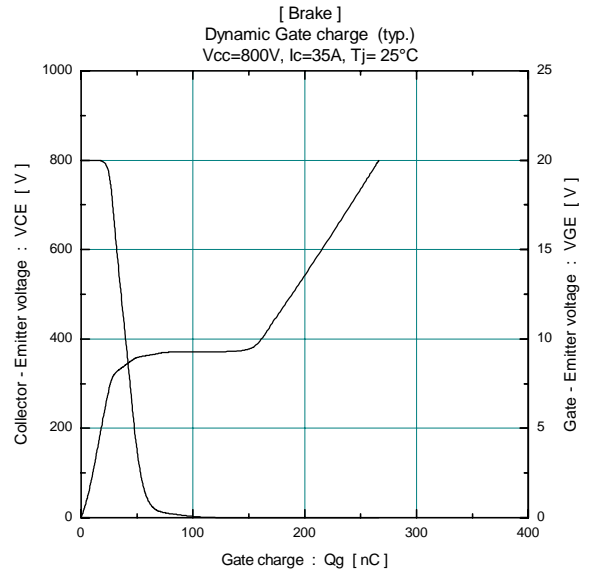
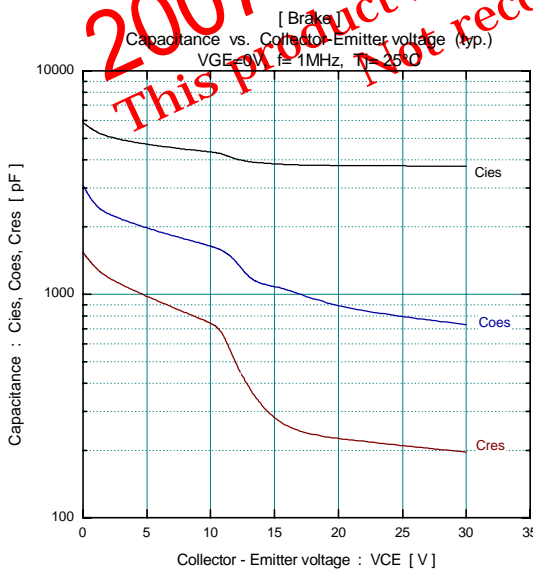
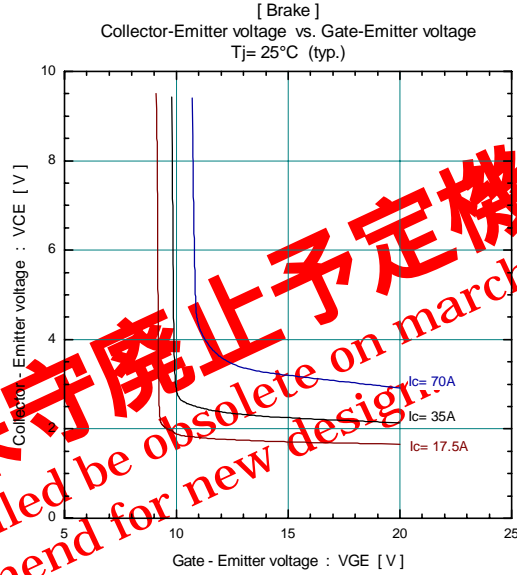
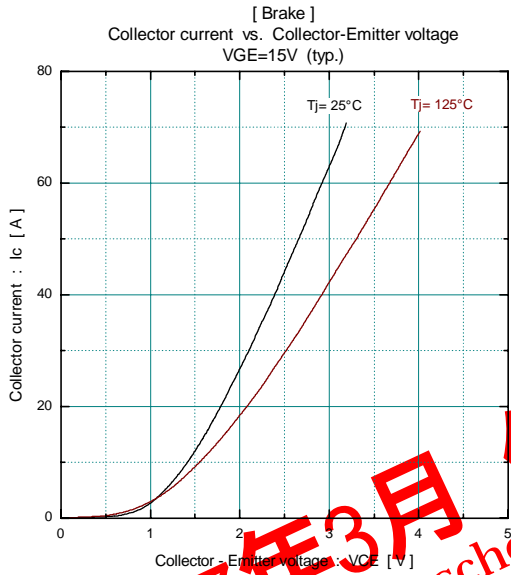
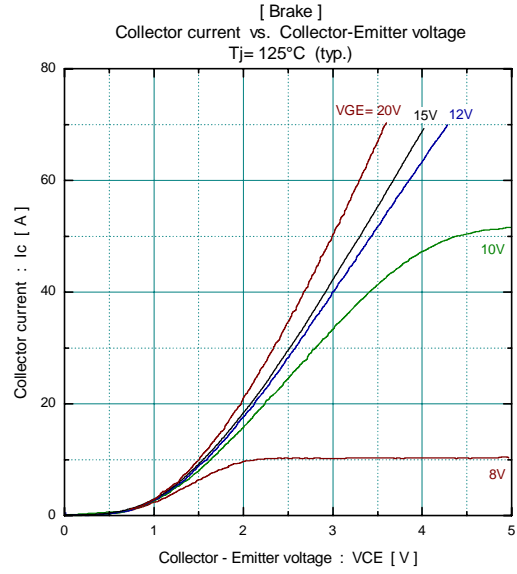
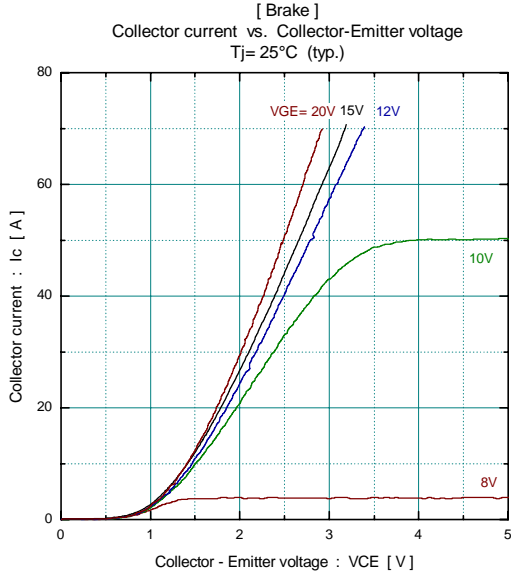

2007年3月 保守廃止予定機種
 This product is scheduled to be obsolete on march 2007.
 Not recommend for new design.

■ Outline Drawings, mm

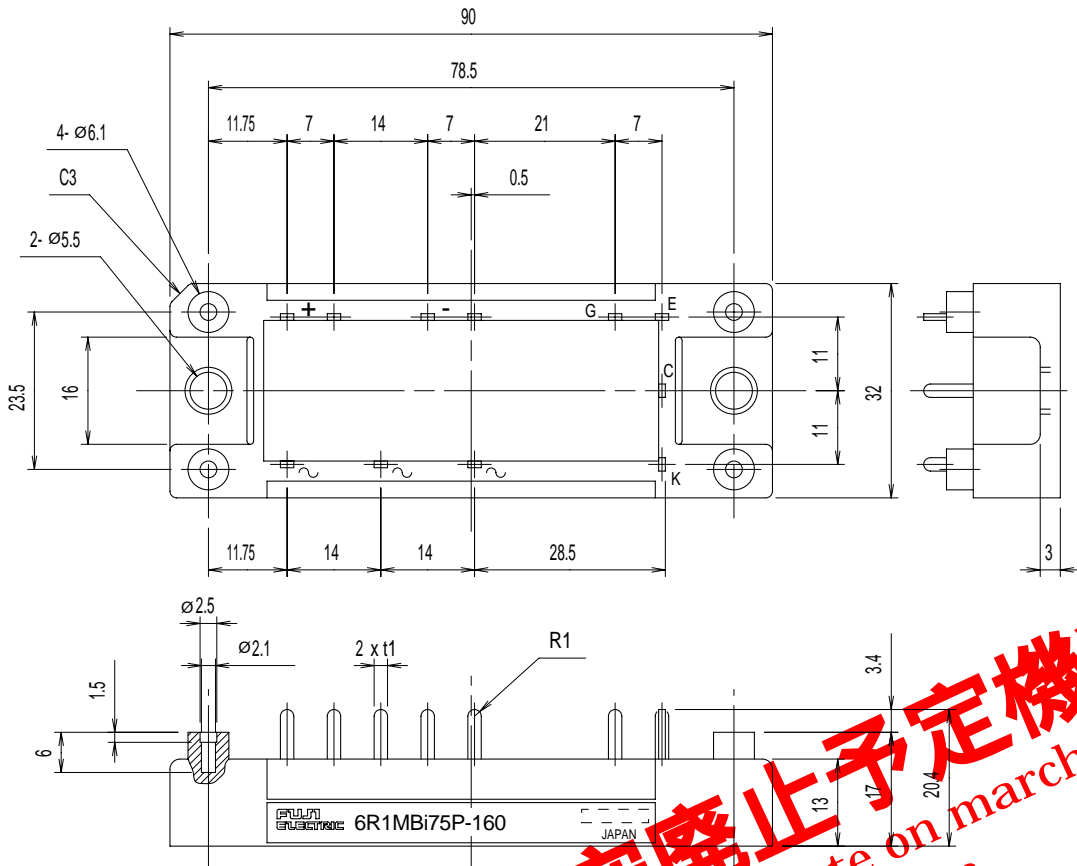

■ Equivalent Circuit Schematic

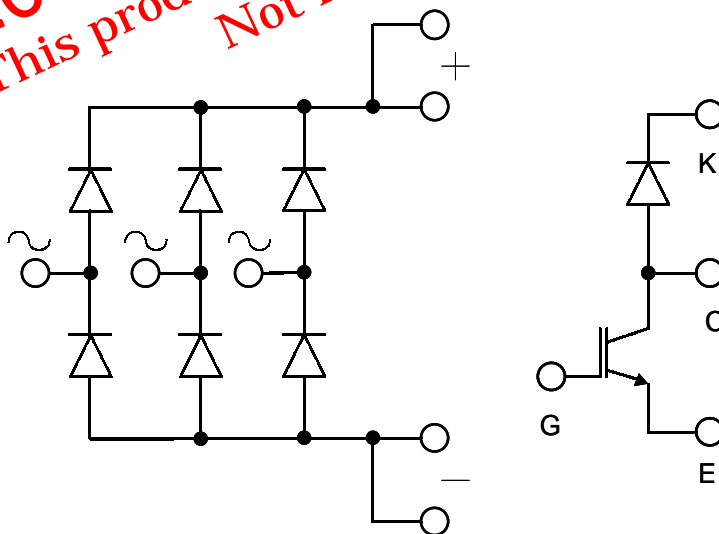

2007年3月 保守廃止予定機種
 This product is scheduled be obsolete on march 2007.
 Not recommend for new design.