

ACX703AKM

By combining the ACX301AK, which concentrates Sony's low-temperature polysilicon TFT LCD technology, with Sony's unique and superlative reflective technology, Sony has succeeded in developing a revolutionary small reflective panel, the ACX703AKM, that achieves low power, high resolution, high contrast, high reflection ratio, and the ability to display pure white.

This device is optimal for use in digital still cameras, which require low power and high picture quality.

Sony has developed, at the same time, two drive IC options to powerfully support this reflective LCD panel. One is the single-chip IC CXA3268R, and the other is a two-chip system timing generator IC CXD2472R. Thus the ACX703AKM can respond to a wide range of product planning needs.

- Reflective LCD based on the ACX301AK 2.0-inch 200K-dot color LCD
- High contrast provided by the ECB mode reflective color LCD
- High reflection ratio provided by a diffusing reflective electrode which adopts the RMP structure
- Natural color and pure white display provided by BDM technology
- Supports NTSC/PAL 16:9 mode
- Powerfully supported by related products.

Low-power Circuits Used

The ACX703AKM uses the same circuits as the ACX301AK 2.0-inch 200K-dot color LCD. These internal circuits are all formed from low-temperature polysilicon TFTs, and thus this product achieves a power consumption of 50 mW when 12-V drive is used. Thus this product, through the use of low-power circuits, is a panel system that strives for even more ultralow-power consumption, which is a feature of reflective LCD panels that do not require a backlight.

Sony's Unique Reflective LCD Panel Technology

In addition to low-power technology, Sony has taken full advantage of the unique high picture quality technologies, including ECB*¹ mode, the RMP*² structure, and the BDM*³ technology, all of which achieve improved brightness and higher contrast. This has resulted in the achievement of a reflection ratio of 28% and a contrast ratio of 19:1.

*1: Electrically Controlled Birefringence

*2: Random Multi Profile

*3: Birefringence Dispersion Matching

Related Products that Powerfully Support the ACX703AKM and the ACX300 Series

Sony provides two types of system as the ACX703AKM drive ICs to support customer needs.

One is a two-chip structure based on existing driver ICs using the CXD2472R as the timing generator. (See figure 1.) The other is a single-chip structure based on the CXA3268R, and allows reduced space and a smaller number of components. (See figure 2.) These options allow customers to select a structure that fits their product designs. Both these drive ICs can also drive the ACX300AK, ACX301AK, and ACX302AK*⁴, which are transmissive panels. Sony is also releasing, at the same time, a backlight specially designed for use with the ACX301AK, which is a 2.0-inch 200K-dot transmissive panel. The ACX301AK backlight adopts a unified structure with the panel itself, and thus can achieve the light weight, small-sized, and low power that are optimal for digital still camera applications.

*4: See pages 22 and 23 for more information on the ACX300AK, ACX301AK, and ACX302AK.

V O I C E

Sony has developed the reflective LCD of the ACX301AK. While the ACX703AKM, which takes full advantage of Sony's unique high-performance reflective LCD technology, is a high-resolution reflective LCD, this product is designed to achieve low power consumption. This device, along with Sony's drive ICs that support all types of application, form a powerful combination that is strongly differentiated from the competition. I strongly recommend that you look into this product.



New Products

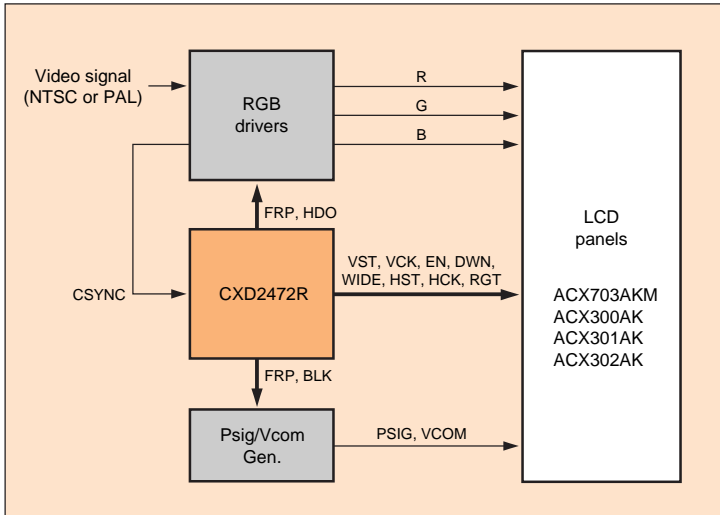

■ Figure 1 ACX703AKM Drive System Block Diagram (Two-chip Structure)



■ Photograph 1 Backlight Designed for Use with the ACX301AK

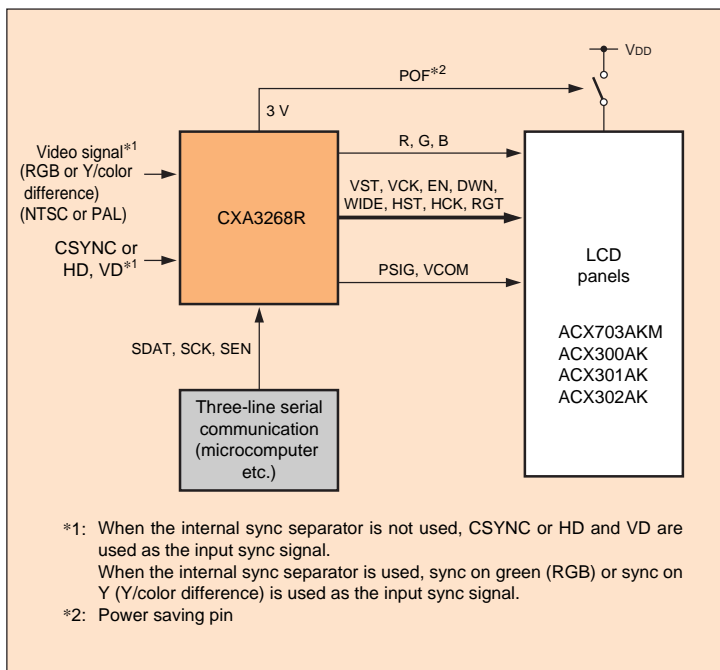

■ Figure 2 ACX703AKM Drive System Block Diagram (Single-chip Structure)

■ Table 1 ACX301AK Backlight Module Specifications

| Item | BL specifications | Module specifications |
|---------------------|-------------------|--|
| Center brightness | 4200 nt | 250 nt |
| Tube power | 0.48 W | — |
| Structure | Side light | — |
| External dimensions | — | 50.2 × 43.6 × 5.8 t |
| Harness | Wire | Wire |
| | | +0.5-mm pitch 24-pin flexible cable |
| Tc | 9500K | 6500K |
| Weight | Approximately 8 g | Approximately 21 g |

■ Table 2 2.0-inch Reflective LCD Specifications

| Item | 2.0-inch 200K-dot LCD | |
|---------------------------------|-----------------------|--|
| Number of active pixels (H × V) | 880 × 228 | |
| Pixel arrangement | Delta arrangement | |
| Dot pitch | 46 × 134 μm | |
| Package dimensions | 44.2 × 49.8 × 2.2 t | |
| Aperture ratio | 76% | |
| Reflection ratio | 28% | |
| Contrast | 19:1 | |
| Power consumption | Whole panel | 50 mW |
| | Whole system | 230 mW (When a single chip structure is used) |