



## Features

- Operating temperature range up to 125 °C
- Low thermal derating factor
- Higher hold currents at elevated temperature
- Choice of operating currents
- RoHS compliant\* and Pb free

## Applications

- Protection of automotive circuitry including engine control modules
- Overcurrent surge protection of electronic equipment required to operate at high operating temperature ranges
- Resettable fault protection of general electronic equipment

# MF-RHT Series - PTC Resettable Fuses

### Electrical Characteristics

Model	V max. Volts	I max. Amps	I <sub>hold</sub>	I <sub>trip</sub>	Resistance		Max. Time To Trip		Tripped Power Dissipation
			Amperes at 23 °C		Ohms at 23 °C		Amperes at 23 °C	Seconds at 23 °C	Watts at 23 °C
			Hold	Trip	R <sub>Min.</sub>	R <sub>1Max.</sub> (Post Trip)	Max.	Typ.	
MF-RHT070	16	40	0.7	1.4	0.3	0.8	3.5	4.0	1.4
MF-RHT200	16	100	2.0	3.8	0.045	0.110	12.5	3.0	1.4
MF-RHT450	16	100	4.5	7.8	0.022	0.054	22.5	3.0	3.6
MF-RHT650	16	100	6.5	12.0	0.011	0.026	32.5	5.5	4.3
MF-RHT750	16	100	7.5	13.1	0.0094	0.022	37.5	7.0	4.5
MF-RHT1300	16	100	13.0	24.0	0.0041	0.010	60.0	13.0	6.9

### Environmental Characteristics

Operating Temperature .....	-40 °C to +125 °C
Storage Temperature .....	-40 °C to +85 °C
Passive Aging .....	+85 °C, 1000 hours .....±15 % typical resistance change
Humidity Aging .....	+85 °C, 85 % R.H. 1000 hours .....±15 % typical resistance change
Thermal Shock .....	MIL-STD-202, Method 107, .....±10 % typical resistance change +125 °C to -40 °C, 10 cycles
Vibration .....	MIL-STD-883C, Method 2007.1, Condition A.....No change

### Test Procedures And Requirements For Model MF-RHT Series

Test	Test Conditions	Accept/Reject Criteria
Visual/Mech. ....	Verify dimensions and materials .....	Per MF physical description
Resistance.....	In still air @ 23 °C .....	R <sub>min</sub> ≤ R ≤ R <sub>1max</sub>
Time to Trip .....	At specified current, V <sub>max</sub> , 23 °C .....	T ≤ max. time to trip (seconds)
Hold Current .....	30 min. at I <sub>hold</sub> .....	No trip
Trip Cycle Life .....	V <sub>max</sub> , I <sub>max</sub> , 100 cycles .....	No arcing or burning
Trip Endurance .....	V <sub>max</sub> , 48 hours.....	No arcing or burning
Solderability .....	MIL-STD-202, Method 208.....	95 % min. coverage

### Thermal Derating Chart - I<sub>hold</sub> (Amps)

Model	Ambient Operating Temperature									
	-40 °C	-20 °C	0 °C	23 °C	40 °C	50 °C	60 °C	70 °C	85 °C	125 °C
MF-RHT070	0.95	0.87	0.79	0.7	0.62	0.56	0.51	0.47	0.39	0.17
MF-RHT200	2.71	2.49	2.26	2.00	1.77	1.60	1.46	1.34	1.11	0.49
MF-RHT450	6.1	5.6	5.1	4.5	4.0	3.6	3.3	3.0	2.5	1.1
MF-RHT650	8.8	8.1	7.4	6.5	5.7	5.3	4.8	4.3	3.6	1.6
MF-RHT750	10.2	9.4	8.6	7.5	6.6	6.1	5.6	5.0	4.1	1.9
MF-RHT1300	17.7	16.3	14.8	13.0	11.4	10.5	9.6	8.6	7.2	3.3



**Asia-Pacific:** Tel: +886-2 2562-4117 • Fax: +886-2 2562-4116  
**Europe:** Tel: +41-41 768 5555 • Fax: +41-41 768 5510  
**The Americas:** Tel: +1-951 781-5500 • Fax: +1-951 781-5700  
[www.bourns.com](http://www.bourns.com)

\*RoHS Directive 2002/95/EC Jan 27 2003 including Annex  
 Specifications are subject to change without notice.  
 Customers should verify actual device performance in their specific applications.

# MF-RHT Series - PTC Resettable Fuses

# BOURNS®

## Product Dimensions

Model	A	B	C		D	E	F	Physical Characteristics	
	Max.	Max.	Nom.	Tol. ±	Min.	Max.	Nom.	Style	Material
MF-RHT070	6.86 (0.27)	10.8 (0.425)	5.1 (0.201)	0.7 (0.028)	7.6 (0.30)	3.0 (0.12)	0.51 (0.020)	1	Sn/CuFe
MF-RHT200	9.4 (0.37)	14.0 (0.55)	5.1 (0.201)	0.7 (0.028)	7.6 (0.30)	3.0 (0.12)	0.51 (0.020)	1	Sn/Cu
MF-RHT450	10.4 (0.41)	15.6 (0.61)	5.1 (0.201)	0.7 (0.028)	7.6 (0.30)	3.0 (0.12)	0.81 (0.032)	2	Sn/Cu
MF-RHT650	12.7 (0.50)	22.2 (0.88)	5.1 (0.201)	0.7 (0.028)	7.6 (0.30)	3.0 (0.12)	0.81 (0.032)	2	Sn/Cu
MF-RHT750	14.0 (0.55)	23.5 (0.93)	5.1 (0.201)	0.7 (0.028)	7.6 (0.30)	3.0 (0.12)	0.81 (0.032)	2	Sn/Cu
MF-RHT1300	23.5 (0.925)	28.7 (1.17)	10.2 (0.402)	0.7 (0.028)	7.6 (0.30)	3.6 (0.14)	1.0 (0.040)	2	Sn/Cu

Packaging:

BULK: 500 pcs. per bag

TAPE & REEL: MF-RHT070 ~ MF-RHT200 = 3000 pcs. per reel; MF-RHT450 ~ MF-RHT650 = 1500 pcs. per reel; MF-RHT750 ~ MF-RHT1300 = 1000 pcs. per reel

AMMO-PACK: MF-RHT070 ~ MF-RHT200 = 2000 pcs. per pack; MF-RHT450 ~ MF-RHT750 = 1000 pcs. per pack; MF-RHT1300 = 500 pcs. per pack

0.51 (24AWG)  
0.81 (20AWG)  
1.0 (18AWG)

UNITS =  $\frac{\text{MM}}{\text{(INCHES)}}$

Style 1

Style 2

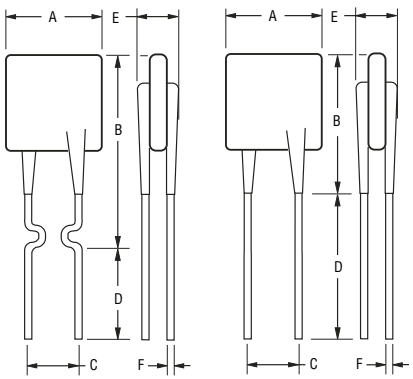

## Typical Part Marking

Represents total content. Layout may vary.

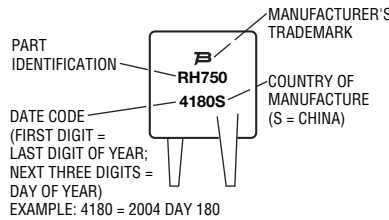

## How to Order

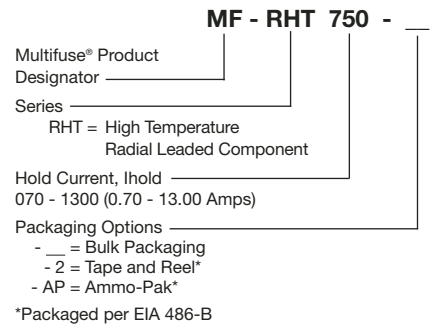

## Typical Time to Trip at 23 °C

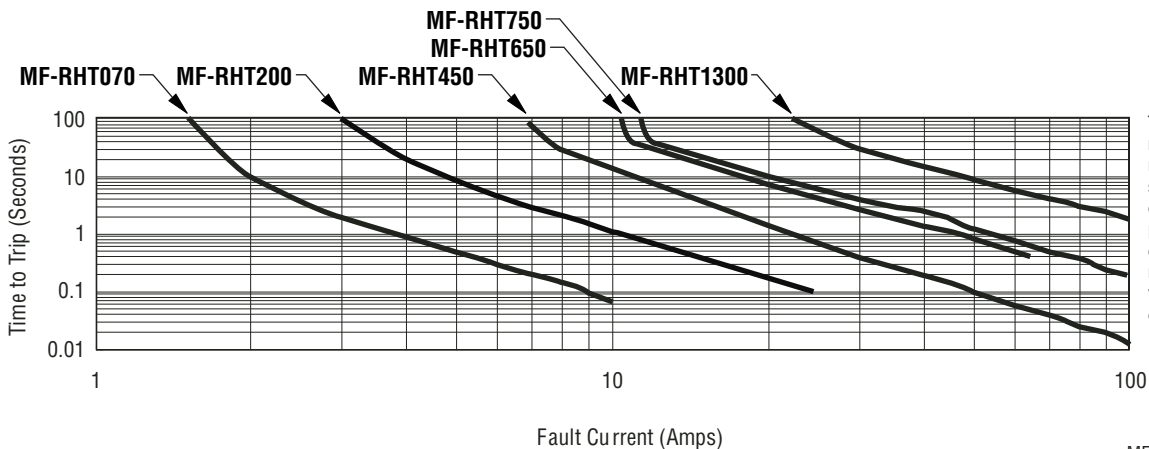

The Time to Trip curves represent typical performance of a device in a simulated application environment. Actual performance in specific customer applications may differ from these values due to the influence of other variables.

# MF-RHT Series Tape and Reel Specifications

**BOURNS®**

Devices taped using EIA468-B/IEC60286-2 standards. See table below and Figures 1 and 2 for details.

Dimension Description	IEC Mark	EIA Mark	Dimensions	
			Dimensions	Tolerance
Carrier tape width	$W$	$W$	$\frac{18}{(.709)}$	$\frac{-0.5/+1.0}{(-0.02/+0.039)}$
Hold down tape width:	$W_0$	$W_4$	$\frac{11}{(.433)}$	min.
Hold down tape			No protrusion	
Top distance between tape edges	$W_2$	$W_6$	$\frac{3}{(.118)}$	max.
Sprocket hole position	$W_1$	$W_5$	$\frac{9}{(.354)}$	$\frac{-0.5/+0.75}{(-0.02/+0.03)}$
Sprocket hole diameter	$D_0$	$D_0$	$\frac{4}{(.157)}$	$\frac{\pm 0.2}{(\pm .0078)}$
Abscissa to plane (straight lead)	$H$	$H$	$\frac{18.5}{(.728)}$	$\frac{\pm 3.0}{(\pm .118)}$
Abscissa to plane (kinked lead)	$H_0$	$H_0$	$\frac{16}{(.63)}$	$\frac{\pm 0.5}{(\pm .02)}$
Abscissa to top: MF-RHT070 ~ MF-RHT450	$H_1$	$H_1$	$\frac{32.2}{(1.268)}$	max.
Abscissa to top: MF-RHT650 ~ MF-RHT1300	$H_1$	$H_1$	$\frac{45.0}{(1.837)}$	max.
Overall width w/lead protrusion: MF-RHT070 ~ MF-RHT450		$C_1$	$\frac{42.5}{(1.673)}$	max.
Overall width w/lead protrusion: MF-RHT650 ~ MF-RHT1300		$C_1$	$\frac{55.0}{(2.165)}$	max.
Overall width w/o lead protrusion: MF-RHT070 ~ MF-RHT450		$C_2$	$\frac{42.5}{(1.673)}$	max.
Overall width w/o lead protrusion: MF-RHT650 ~ MF-RHT1300		$C_2$	$\frac{54.0}{(2.126)}$	max.
Lead protrusion	$l_1$	$L_1$	$\frac{1.0}{(.039)}$	max.
Protrusion of cutout	$L$	$L$	$\frac{11}{(.433)}$	max.
Protrusion beyond hold tape	$l_2$	$l_2$	Not specified	
Sprocket hole pitch	$P_0$	$P_0$	$\frac{12.7}{(0.5)}$	$\frac{\pm 0.3}{(\pm .012)}$
Pitch tolerance			20 consecutive	$\pm 1$
Device pitch: MF-RHT070 ~ MF-RHT450			$\frac{12.7}{(0.5)}$	$\frac{\pm 0.3}{(\pm .012)}$
Device pitch: MF-RHT650 ~ MF-RHT1300			$\frac{25.4}{(1.0)}$	$\frac{\pm 0.6}{(\pm .024)}$
Tape thickness	$t$	$t$	$\frac{0.9}{(.035)}$	max.
Tape thickness with splice: MF-RHT070		$t_1$	$\frac{1.5}{(.059)}$	max.
Tape thickness with splice: MF-RHT450 ~ MF-RHT1300		$t_1$	$\frac{2.3}{(.091)}$	max.
Splice sprocket hole alignment			$\frac{4.0}{(0.157)}$	$\frac{\pm 0.2}{(\pm .008)}$
Body lateral deviation	$\Delta h$	$\Delta h$	0	$\frac{\pm 1.0}{(\pm .039)}$
Body tape plane deviation	$\Delta p$	$\Delta p$	0	$\frac{\pm 0.3}{(\pm .012)}$
Ordinate to adjacent component lead	$P_1$	$P_1$	$\frac{3.81}{(0.15)}$	$\frac{\pm 0.07}{(\pm .028)}$
Lead spacing: MF-RHT070 ~ MF-RHT750	$F$	$F$	$\frac{5.08}{(0.2)}$	$\frac{-0.2/+0.8}{(-.006/+ .031)}$
Lead spacing: MF-RHT1300	$F$	$F$	$\frac{10.2}{(0.402)}$	$\frac{-0.2/+0.8}{(-.006/+ .031)}$
Reel width: MF-RHT070 ~ MF-RHT450	$w$	$W_2$	$\frac{56}{(2.20)}$	max.
Reel width: MF-RHT650 ~ MF-RHT1300	$w$	$W_2$	$\frac{63.5}{(2.50)}$	max.

Specifications are subject to change without notice.  
Customers should verify actual device performance in their specific applications.

DIMENSIONS =  $\frac{\text{MM}}{\text{(INCHES)}}$

# MF-RHT Series Tape and Reel Specifications

**BOURNS®**

Dimension Description	IEC Mark	EIA Mark	Dimensions	
			Dimensions	Tolerance
Reel diameter	$d$	$a$	$\frac{370}{(14.57)}$	max.
Space between flanges less device	$W_1$	$h$	$\frac{4.75}{(.187)}$	$\frac{\pm 3.25}{(\pm .128)}$
Arbor hole diameter	$f$	$c$	$\frac{26}{(1.024)}$	$\frac{\pm 12.0}{(\pm .472)}$
Core diameter	$h$	$n$	$\frac{80}{(3.15)}$	max.
Box			$\frac{64}{(2.52)}$ $\frac{372}{(14.6)}$ $\frac{372}{(14.6)}$	
Consecutive missing places			3	max.
Empty places per reel			Not specified	

**Taped Component Dimensions - Figure 1**

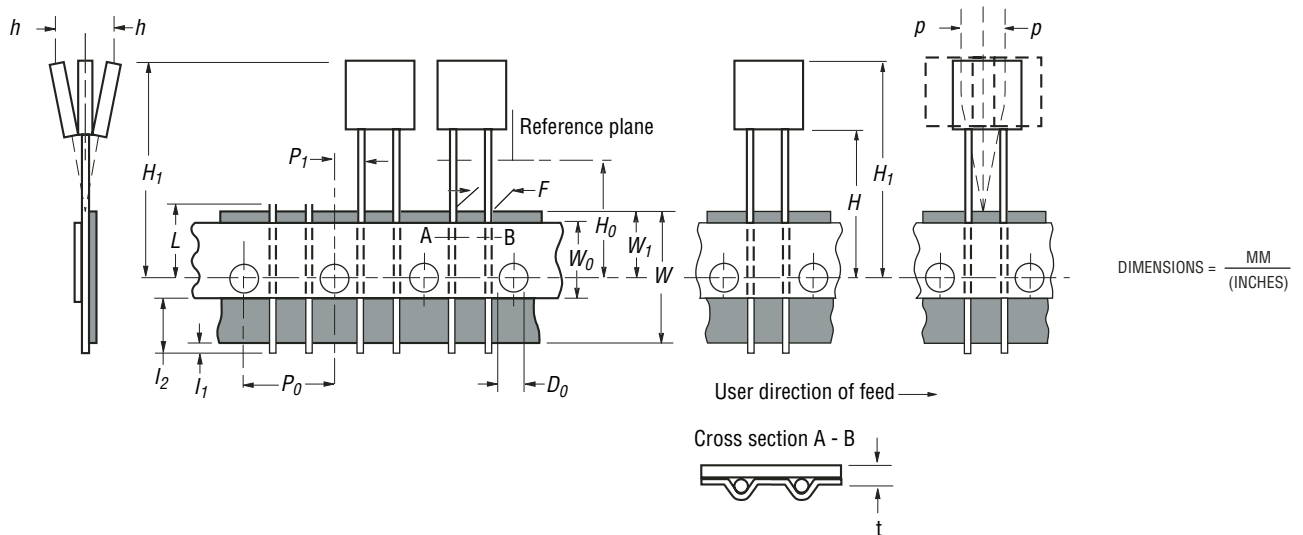

**Reel Dimensions - Figure 2**

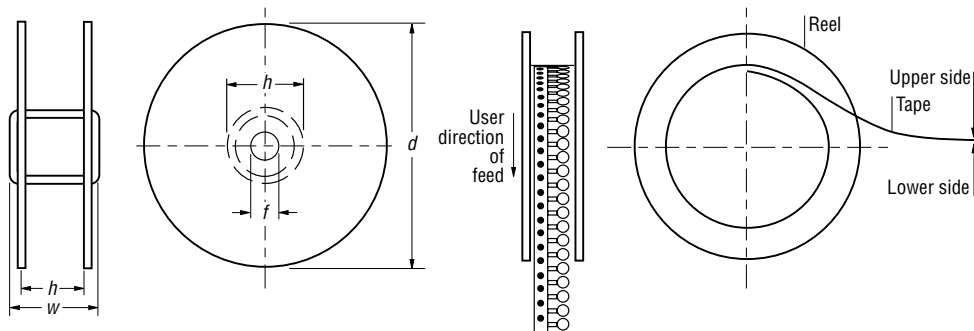

Specifications are subject to change without notice. Customers should verify actual device performance in their specific applications.