

TOSHIBA Bipolar Linear IC Silicon Monolithic

# TA2152FNG

## Low Current Consumption Headphone Amplifier (for 1.5-V/3-V Use)

The TA2152FNG is a headphone amplifier of low current consumption type developed for portable digital audio.

It is especially suitable for portable CD players, portable MD players etc.

### Features

- Low current consumption
  - The power drive stage can be driven using a single battery. As a result, overall current consumption is low.
  - Built-in center amplifier switch  
For the output-coupling type, the consumption current has been decreased still further.
  - Current value ( $V_{CC1} = 2.4\text{ V}$ ,  $V_{CC2} = 1.2\text{ V}$ ,  $f = 1\text{ kHz}$ ,  $R_L = 16\ \Omega$ ,  $T_a = 25^\circ\text{C}$ , typ.)
    - Output-coupling type
      - No Signal:  $I_{CC}(V_{CC1}) = 0.4\text{ mA}$ ,  $I_{CC}(V_{CC2}) = 0.3\text{ mA}$
      - $0.1\text{ mW} \times 2\text{ ch}$ :  $I_{CC}(V_{CC1}) = 0.5\text{ mA}$ ,  $I_{CC}(V_{CC2}) = 2.2\text{ mA}$
      - $0.5\text{ mW} \times 2\text{ ch}$ :  $I_{CC}(V_{CC1}) = 0.5\text{ mA}$ ,  $I_{CC}(V_{CC2}) = 5.0\text{ mA}$
    - OCL type
      - No Signal:  $I_{CC}(V_{CC1}) = 0.7\text{ mA}$ ,  $I_{CC}(V_{CC2}) = 0.7\text{ mA}$
      - $0.1\text{ mW} \times 2\text{ ch}$ :  $I_{CC}(V_{CC1}) = 0.7\text{ mA}$ ,  $I_{CC}(V_{CC2}) = 4.5\text{ mA}$
      - $0.5\text{ mW} \times 2\text{ ch}$ :  $I_{CC}(V_{CC1}) = 0.8\text{ mA}$ ,  $I_{CC}(V_{CC2}) = 10.0\text{ mA}$
  - Output power:  $P_o = 8\text{ mW}$  (typ.)  
( $V_{CC1} = 2.4\text{ V}$ ,  $V_{CC2} = 1.2\text{ V}$ ,  $f = 1\text{ kHz}$ ,  $R_L = 16\ \Omega$ , THD = 10%,  $T_a = 25^\circ\text{C}$ )
  - Built-in beep function
  - Built-in low-pass compensation (output-coupling type)
  - Built-in mute switch
  - Built-in power switch
  - Operating supply voltage range ( $T_a = 25^\circ\text{C}$ )
    - $V_{CC1}(\text{opr}) = 1.8\text{ V} \sim 4.5\text{ V}$
    - $V_{CC2}(\text{opr}) = 0.9\text{ V} \sim 4.5\text{ V}$

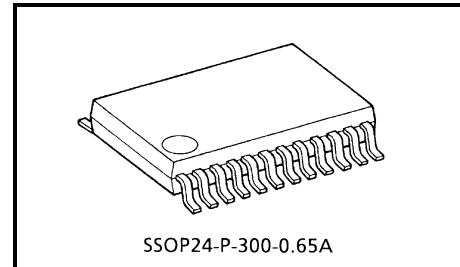

Weight: 0.14 g (typ.)

## Block Diagram (of OCL Application)

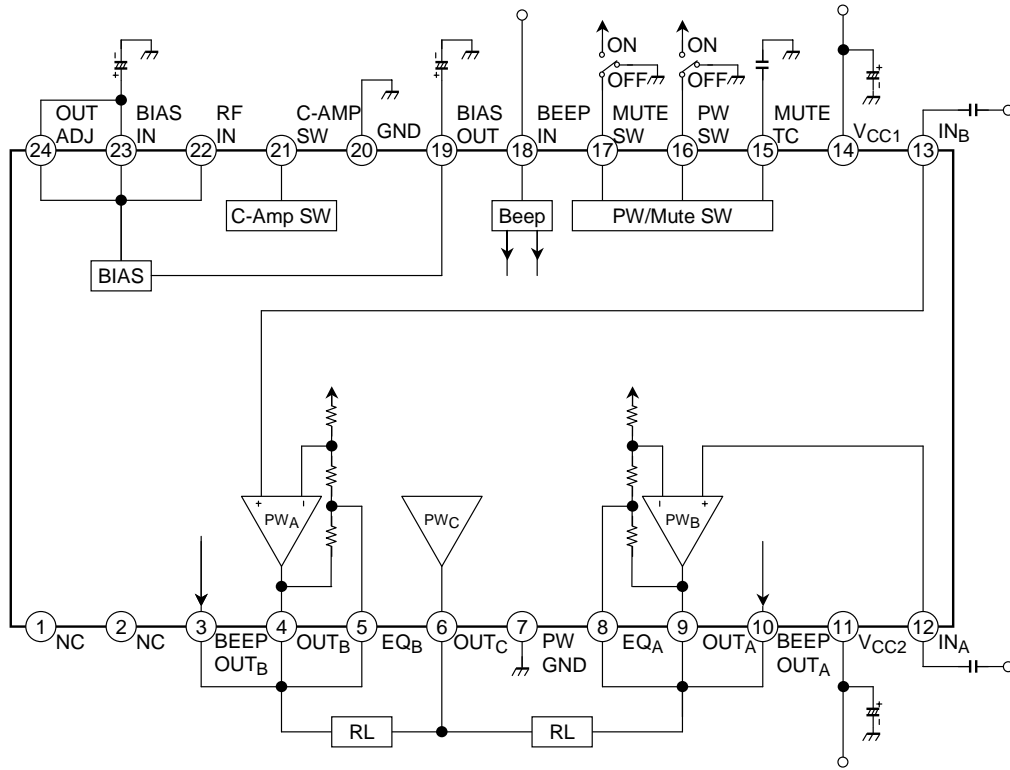

## Pin Descriptions

**Pin Voltage: Typical pin voltage for test circuit when no input signal is applied**  
 ( $V_{CC1} = 2.4 \text{ V}$ ,  $V_{CC2} = 1.2 \text{ V}$ ,  $T_a = 25^\circ\text{C}$ )

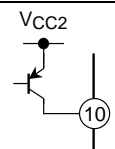
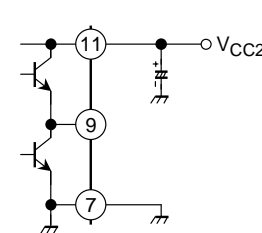
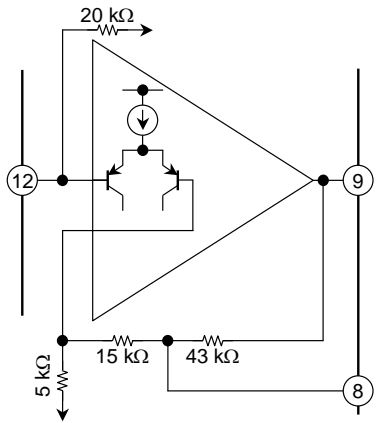
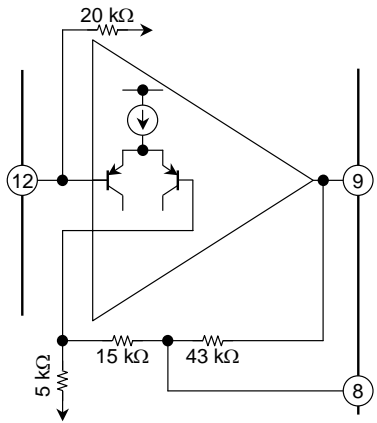
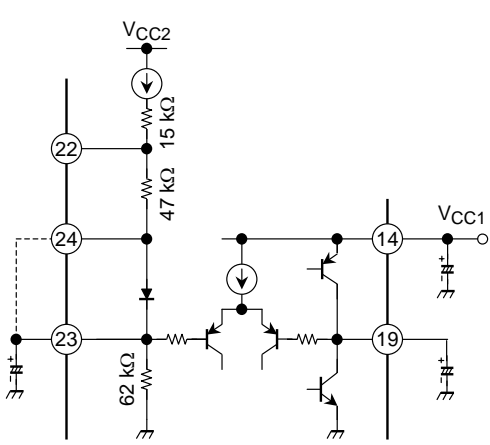
Pin		Function	Internal Circuit	Pin Voltage (V)
No.	Name			
1	NC	Not connected	—	—
2	NC			
3	BEEP OUT <sub>B</sub>	Outputs for beep signal		—
10	BEEP OUT <sub>A</sub>			
4	OUT <sub>B</sub>	Outputs from power amplifier		0.6
6	OUT <sub>C</sub>			
9	OUT <sub>A</sub>			
7	PW GND			GND for power drive stage
11	V <sub>CC2</sub>	V <sub>CC</sub> for power drive stage		1.2
5	EQ <sub>B</sub>	Low-pass compensation pins		0.6
8	EQ <sub>A</sub>			
12	IN <sub>A</sub>	Inputs to power amplifier		0.6
13	IN <sub>B</sub>			
14	V <sub>CC1</sub>	V <sub>CC</sub> for everything other than power drive stage		2.4
19	BIAS OUT	Bias circuit output		0.6
22	RF IN	Ripple filter input		1.1
23	BIAS IN	Bias circuit output		0.6
24	OUT ADJ	DC output voltage adjustment Either connect this pin or leave it open depending on the level of V <sub>CC2</sub> . If the power supply of a 1.5 V system is applied to V <sub>CC2</sub> , connect this pin to BIAS IN (pin 23). If the power supply of a 3 V system is applied to V <sub>CC2</sub> , leave this pin open.		0.6

Pin		Function	Internal Circuit	Pin Voltage (V)
No.	Name			
15	MUTE TC	Mute smoothing Reduces popping noises during switching.		—
16	PW SW	Power switch IC ON :H level IC OFF :L level Refer to application note (6)		—
17	MUTE SW	Mute switch Mute OFF: L level Mute ON: H level Refer to application note (6)		—
18	BEEP IN	Beep signal input If the beep function is not used, this pin should be connected to GND.		—
20	GND	GND for everything other than power drive stage	—	0
21	C-AMP SW	Center amplifier switch C-Cup type: GND OCL type: Open		—

**Application Notes**

**(1) Beep function**

In Power Mute Mode, the beep signal from the microcomputer or other controlling device is input on the BEEP IN pin (pin 18). This signal is output as a current which flows to the load via the BEEP output pin (pin 3/10). The beep level is set to  $V_o = -50\text{dBV}$  ( $R_L = 16 \Omega$  (typ.)). For the beep signal timing, please refer to Figure 1.

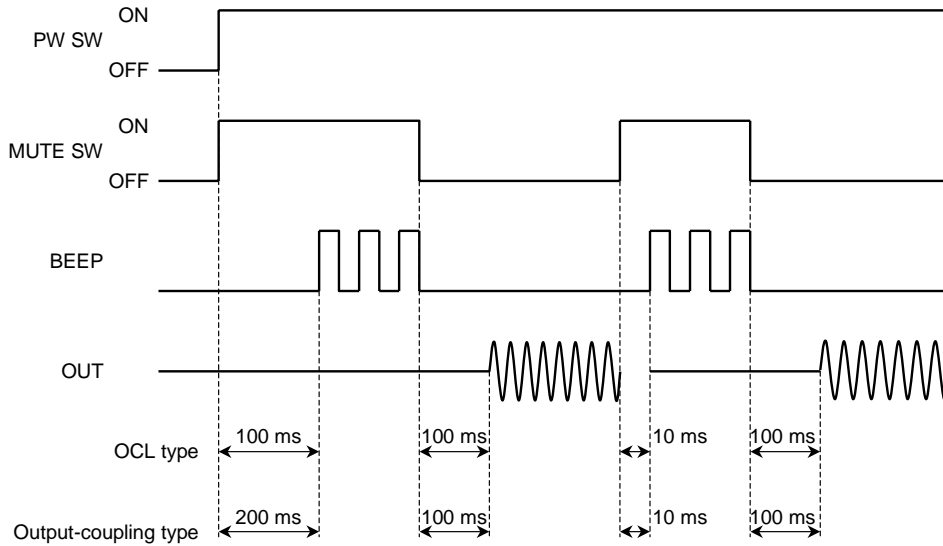

**Figure 1 Timing chart for beep and output signals**

**(2) Low-cut compensation**

For output-coupling type, the low-frequency range can be decreased using an output-coupling capacitor and a load ( $f_c = 45 \text{ Hz}$  at  $C = 220 \mu\text{F}$ ,  $R = 16 \Omega$ ). However, since the capacitor is connected between the IC's output pin (pin 4/9) and EQ pin (pin 5/8), the low-frequency gain of the power amplifier increases, enabling low-cut compensation to be performed. For the response of capacitors of different values, please refer to Figure 2.

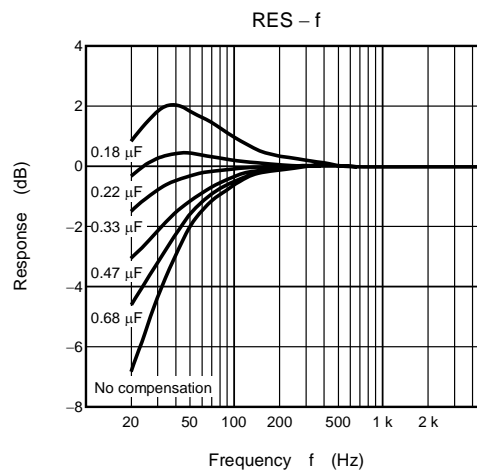

**Figure 2 Capacitor response**

**(3) Adjustment of DC output voltage**

Please perform the OUT ADJ pin (pin 24) as follows by the power supply of VCC1 and VCC2.

- If a boost voltage is applied to VCC1, VCC2 is connected to a battery and the difference between VCC1 and VCC2 is greater than or equal to 0.7 V, short pins 23 and 24 together. In this case the DC output voltage will be  $\frac{V_{CC2}}{2}$ .
- If the difference between VCC1 and VCC2 is less than 0.7 V, or if VCC1 and VCC2 are connected to the same power supply, leave pin 24 open.

In these cases the DC output voltage will be  $\frac{V_{CC2} - 0.7 V}{2}$ .

However, when the voltage level of VCC2 is high, the DC output voltage is will be set to approximately 1.4 V.

**(4) RF IN pin**

The ripple rejection ratio can be improved by connecting a capacitor to this pin. Connection of a capacitor is recommended, particularly for output-coupling type.

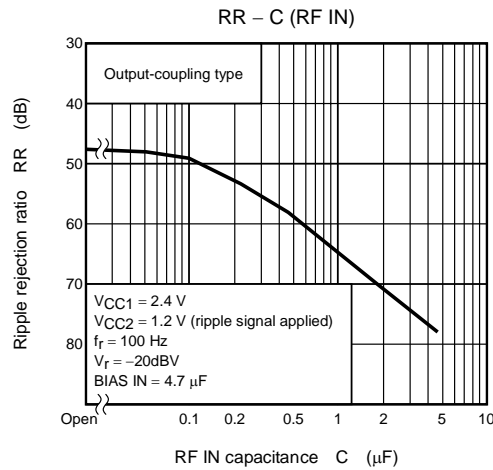

**Figure 3 Improvement of ripple rejection ratio**

**(5) Output application of power amplifier**

For output-coupling type the center amplifier is not used with the result that current consumption is low. Please set the C-AMP SW pin (pin 21) accordingly.

- Output-coupling type: Pin 21 is connected to GND.
- OCL type: Pin 21 is open.

**(6) Switching pins**

**(a) PW SW**

The device is ON when this pin is set to High. To prevent the IC being turned ON by external noise, it is necessary to connect an external pull-down resistor to the PW SW pin. The pin is highly sensitive.

**(b) MUTE SW**

If the MUTE SW pin is fixed to High, current will flow through the pin, even when the PW SW pin is in OFF Mode. To prevent the IC being turned ON by external noise, it is necessary to connect an external pull-down resistor.

The pop noise heard when the MUTE SW switch is turned ON or OFF can be reduced by connecting an external capacitor to the MUTE TC pin.

**(c) Switch sensitivity (Ta = 25°C)**

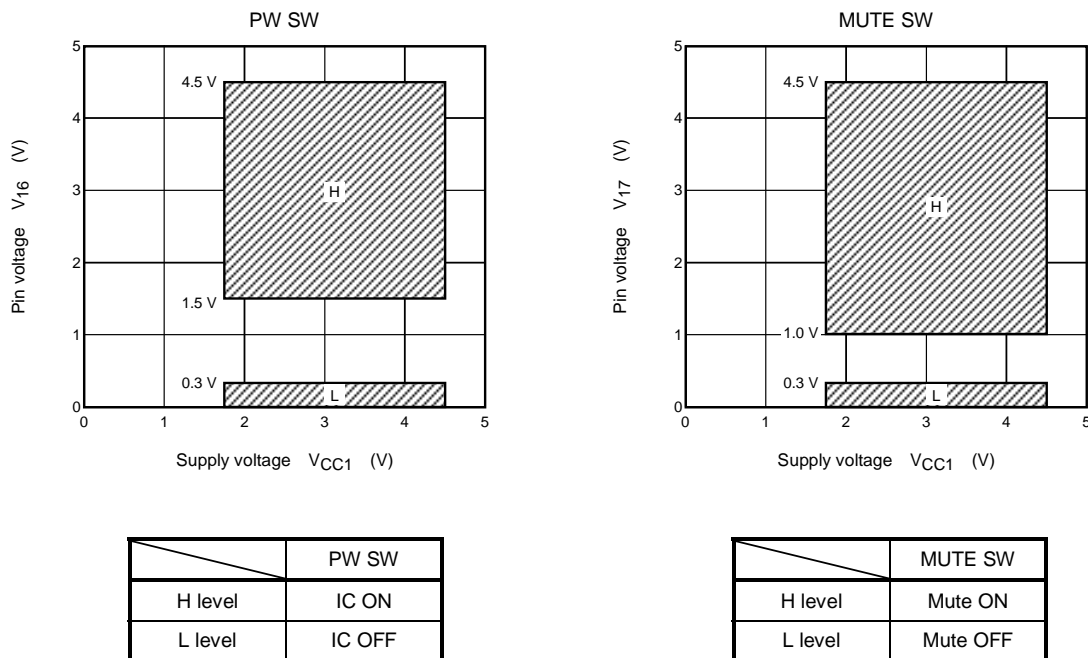

**Figure 4 Switch sensitivity**

**(7) Miscellaneous**

The following capacitors must have excellent temperature and frequency characteristics.

- Capacitor between VCC1 (pin 14) and GND (pin 20)
- Capacitor between VCC2 (pin 11) and PW GND (pin 7)
- Capacitor between BIAS IN (pin 23) and GND (pin 20)
- Capacitor between BIAS OUT (pin 19) and GND (pin 20)
- Capacitor between RF IN (pin 22) and GND (pin 20)

## Absolute Maximum Ratings (Ta = 25°C)

Characteristic	Symbol	Rating	Unit
Supply voltage 1	V <sub>CC1</sub>	4.5	V
Supply voltage 2	V <sub>CC2</sub>	4.5	
Output current	I <sub>o</sub> (peak)	100	mA
Power dissipation	P <sub>D</sub> (Note)	500	mW
Operating temperature	T <sub>opr</sub>	-25~75	°C
Storage temperature	T <sub>stg</sub>	-55~150	°C

Note: Derated by 4 mW/°C above Ta = 25°C

## Electrical Characteristics

(Unless otherwise specified V<sub>CC1</sub> = 2.4 V, V<sub>CC2</sub> = 1.2 V, R<sub>g</sub> = 600 Ω, R<sub>L</sub> = 16 Ω, f = 1 kHz, Ta = 25°C, SW1: a, SW2: b, SW3: a)

Characteristic	Symbol	Test Conditions	Min	Typ.	Max	Unit	
Quiescent supply current	I <sub>CCQ1</sub>	IC OFF (V <sub>CC1</sub> ), SW1: b	—	0.1	5	μA	
	I <sub>CCQ2</sub>	IC OFF (V <sub>CC2</sub> ), SW1: b	—	0.1	5		
	I <sub>CCQ3</sub>	OCL, Mute ON (V <sub>CC1</sub> ), SW2: a	—	400	600		
	I <sub>CCQ4</sub>	OCL, Mute ON (V <sub>CC2</sub> ), SW2: a	—	650	1400		
	I <sub>CCQ5</sub>	C-Cup, Mute ON (V <sub>CC1</sub> ), SW2: a	—	170	250		
	I <sub>CCQ6</sub>	C-Cup, Mute ON (V <sub>CC2</sub> ), SW2: a	—	85	170		
	Power supply current during drive	I <sub>CC7</sub>	OCL, no signal (V <sub>CC1</sub> )	—	0.7	1.1	mA
		I <sub>CC8</sub>	OCL, no signal (V <sub>CC2</sub> )	—	0.7	1.5	
		I <sub>CC9</sub>	C-Cup, no signal (V <sub>CC1</sub> )	—	0.4	0.6	
		I <sub>CC10</sub>	C-Cup, no signal (V <sub>CC2</sub> )	—	0.3	0.6	
Voltage gain	I <sub>CC1</sub>	OCL, 0.5 mW × 2 ch (V <sub>CC1</sub> )	—	0.8	—	mA	
	I <sub>CC2</sub>	OCL, 0.5 mW × 2 ch (V <sub>CC2</sub> )	—	10.0	—		
	I <sub>CC3</sub>	C-Cup, 0.5 mW × 2 ch (V <sub>CC1</sub> )	—	0.5	—		
	I <sub>CC4</sub>	C-Cup, 0.5 mW × 2 ch (V <sub>CC2</sub> )	—	5.0	—		
Voltage gain	G <sub>V</sub>	V <sub>o</sub> = -22dBV	9.5	11.5	13.5	dB	
Channel balance	CB	V <sub>o</sub> = -22dBV	-1.5	0	1.5		
Output power	P <sub>o</sub>	THD = 10%	5	8	—	mW	
Total harmonic distortion	THD	P <sub>o</sub> = 1 mW	—	0.1	1.0	%	
Output noise voltage	V <sub>no</sub>	R <sub>g</sub> = 600 Ω, Filter: IHF-A, SW3: b	—	-100	-96	dBV	
Crosstalk	CT	V <sub>o</sub> = -22 dBV	-25	-35	—	dB	
Ripple rejection ratio 1	RR1	Inflow to V <sub>CC1</sub> , SW3: b f <sub>r</sub> = 100 Hz, V <sub>r</sub> = -20 dBV	-65	-85	—		
Ripple rejection ratio 2	RR2	Inflow to V <sub>CC2</sub> , SW3: b f <sub>r</sub> = 100 Hz, V <sub>r</sub> = -20 dBV	-85	-100	—		
Muting attenuation	ATT	V <sub>o</sub> = -12dBV	-100	-115	—	dB	
Beep sound output voltage	V <sub>BEEP (OUT)</sub>	V <sub>BEEP (IN)</sub> = 2 V <sub>p-p</sub>	-55	-50	-45	dBV	
PW SW ON current	I <sub>16</sub>	V <sub>CC1</sub> = 1.8 V, V <sub>CC2</sub> = 0.9 V	5	—	—	μA	
PW SW OFF voltage	V <sub>16</sub>	V <sub>CC1</sub> = 1.8 V, V <sub>CC2</sub> = 0.9 V	0	—	0.3	V	
Mute SW ON current	I <sub>17</sub>	V <sub>CC1</sub> = 1.8 V, V <sub>CC2</sub> = 0.9 V	5	—	—	μA	
Mute SW OFF voltage	V <sub>17</sub>	V <sub>CC1</sub> = 1.8 V, V <sub>CC2</sub> = 0.9 V	0	—	0.3	V	



**Test Circuit**

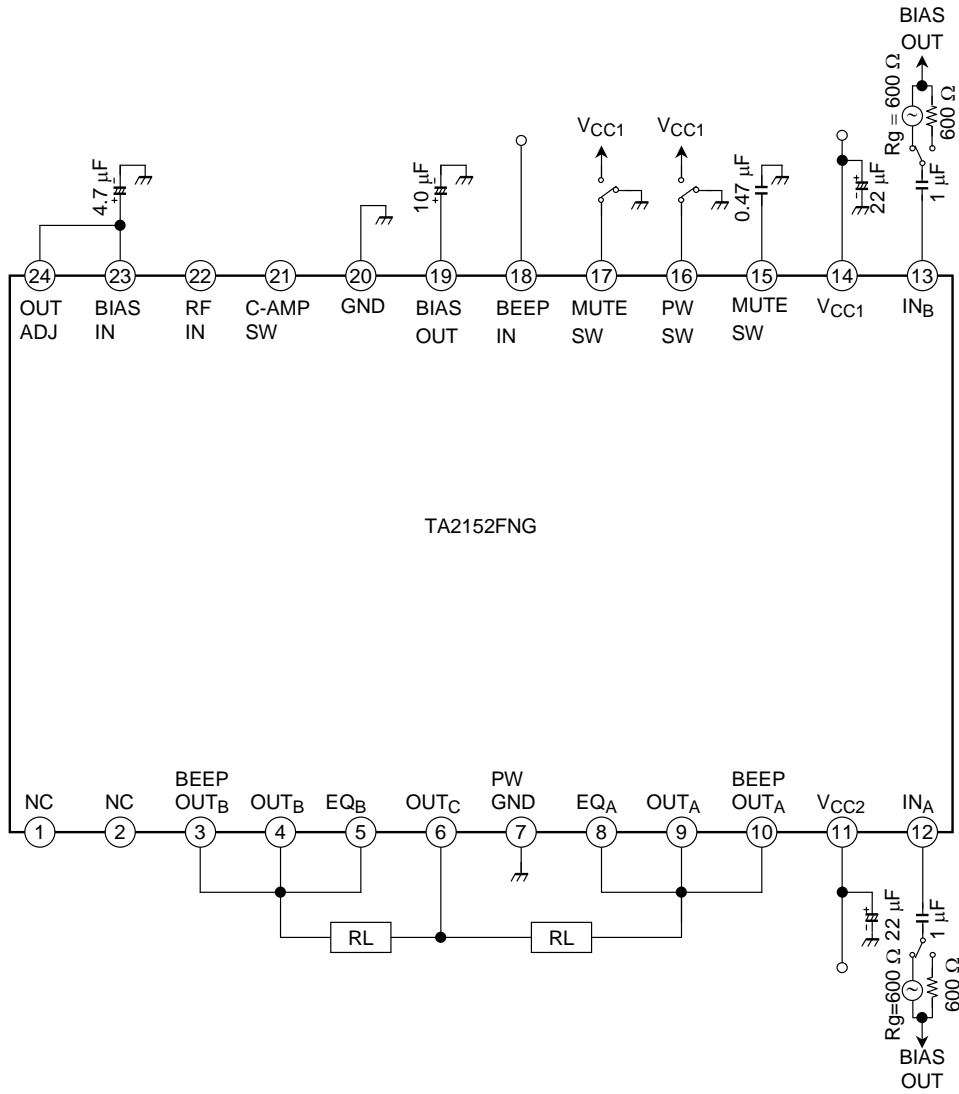

## Characteristic Curves (unless otherwise specified, $V_{CC1} = 2.4\text{ V}$ , $V_{CC2} = 1.2\text{ V}$ , $R_g = 600\ \Omega$ , $R_L = 16\ \Omega$ , $f = 1\text{ kHz}$ , $T_a = 25^\circ\text{C}$ )

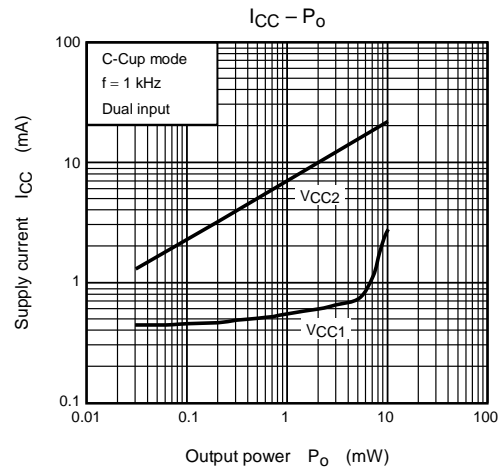
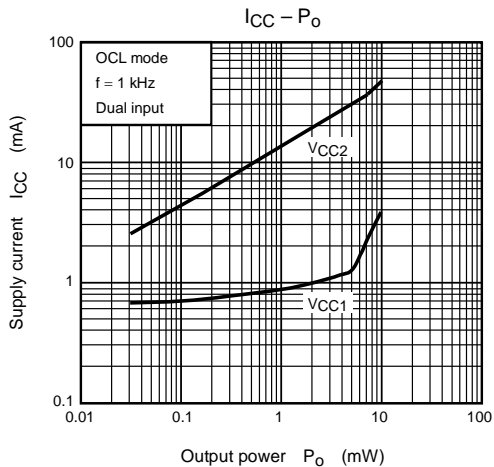
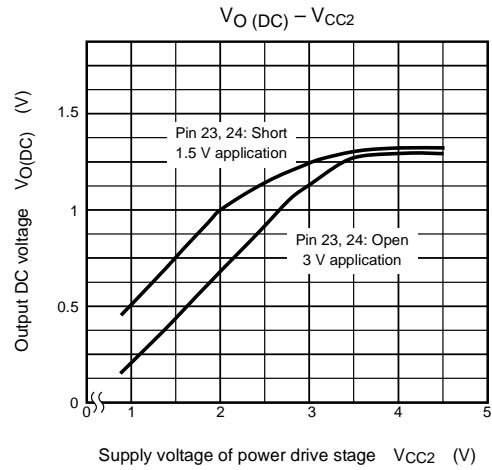
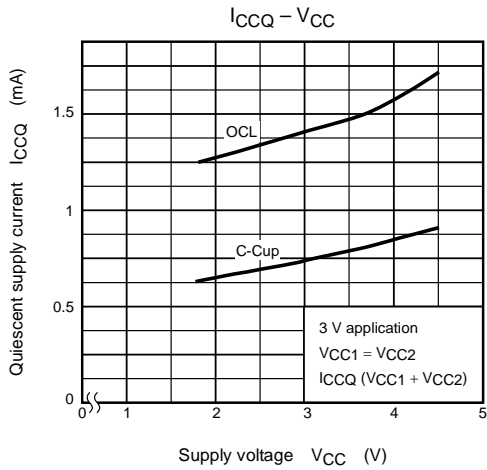
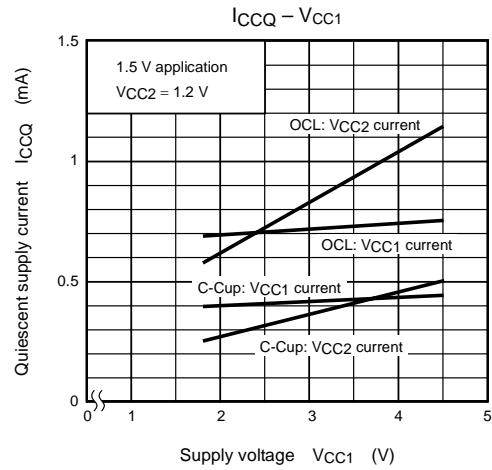
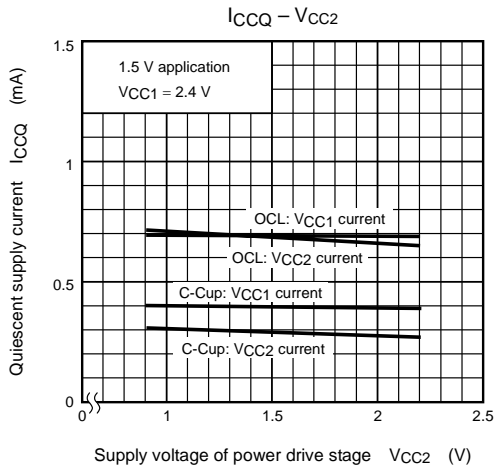

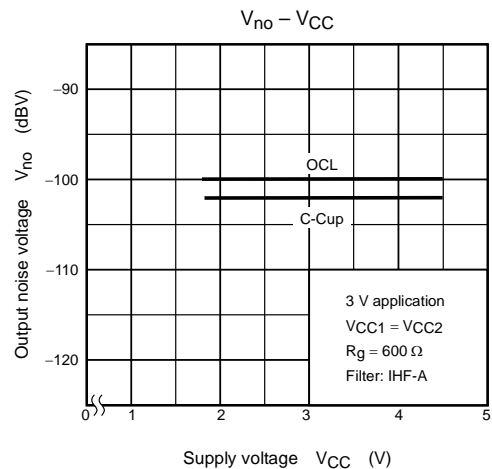
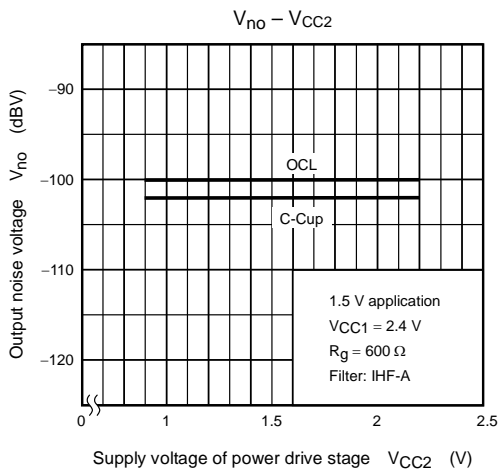
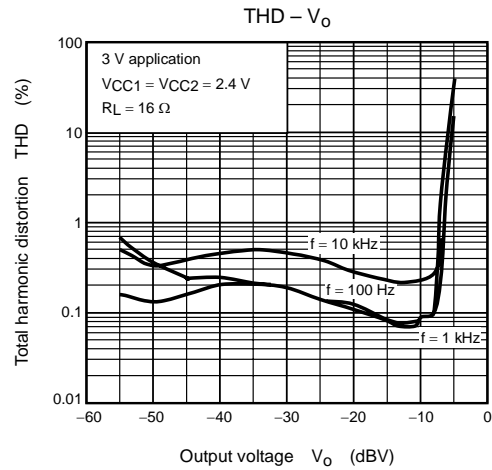
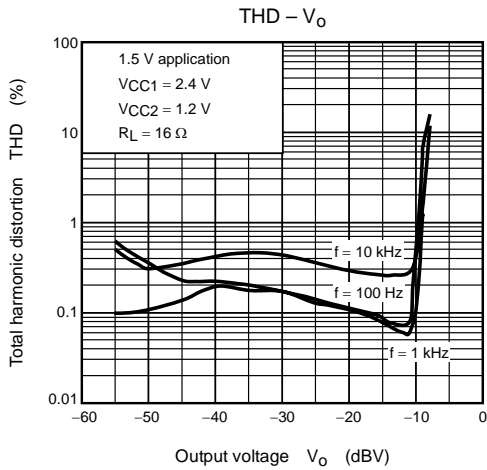
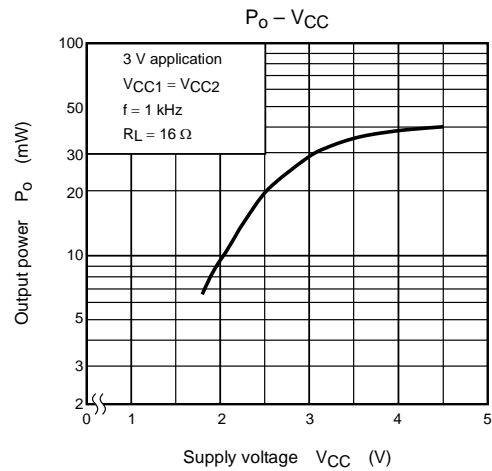
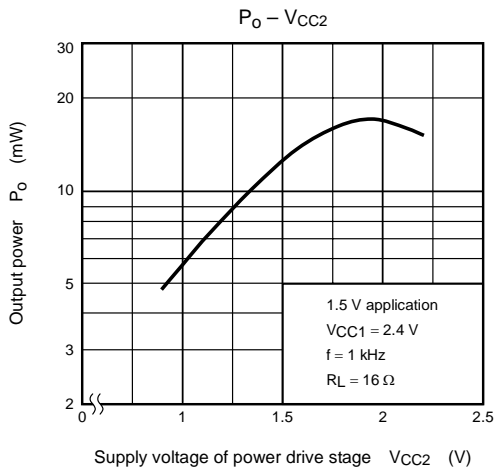

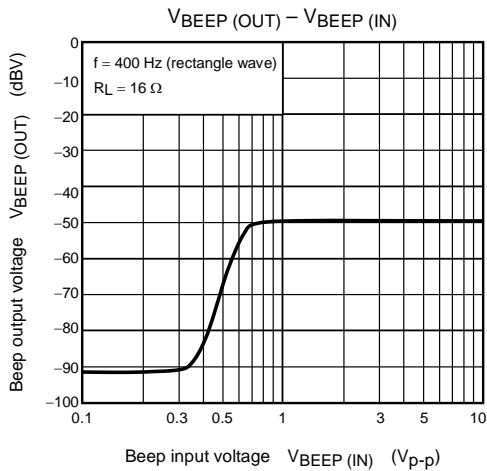
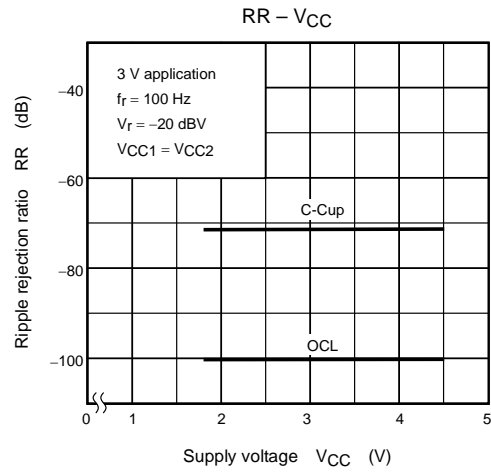
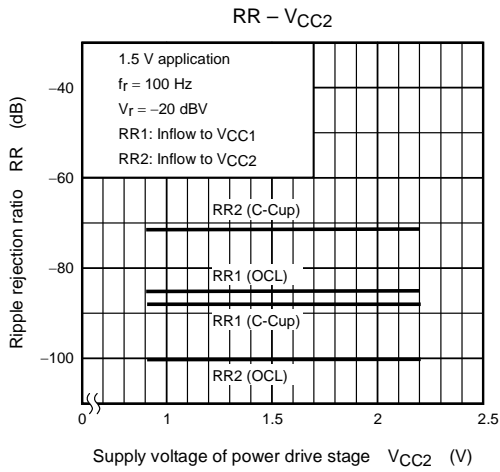
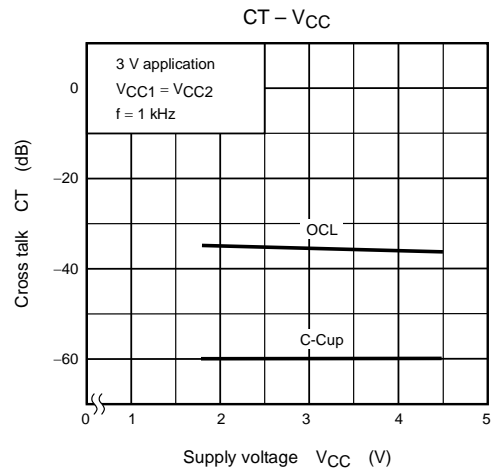
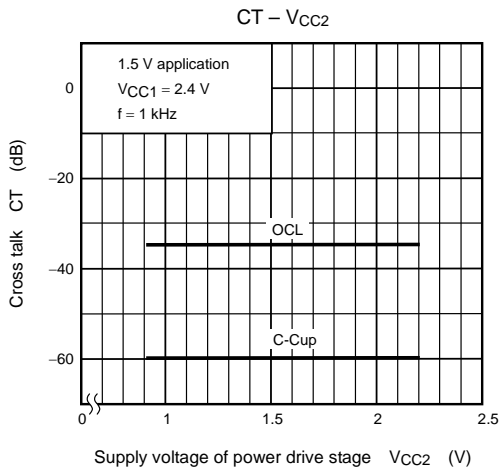

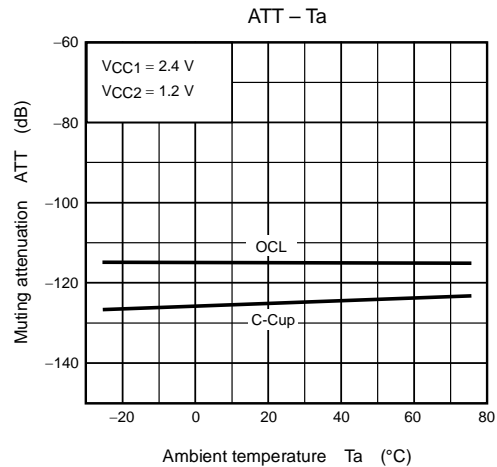
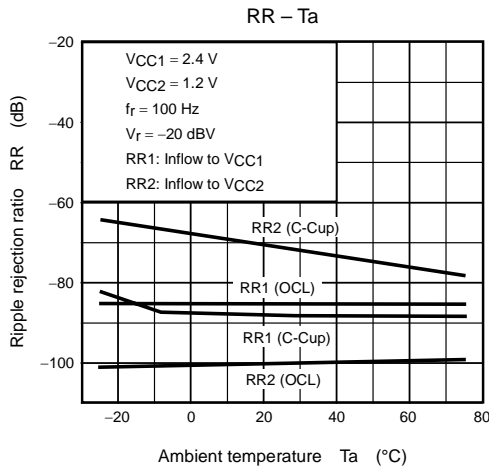
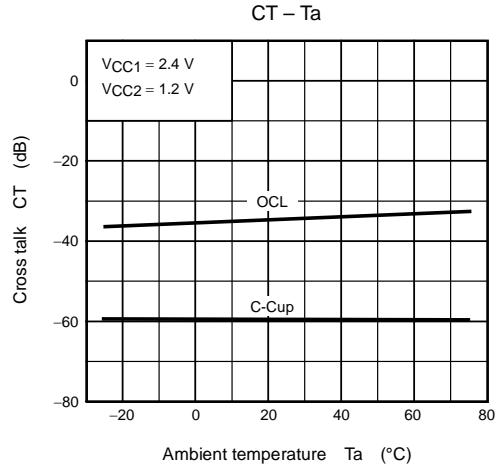
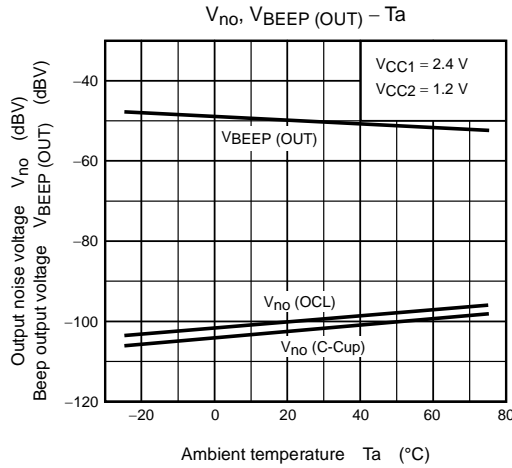
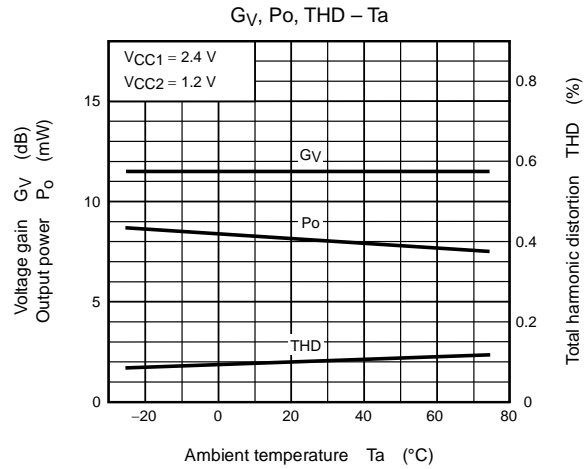
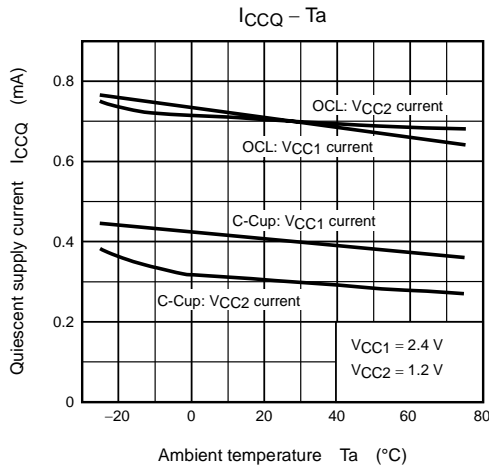

## Application Circuit 1 (1.5 V Output Coupling Type)

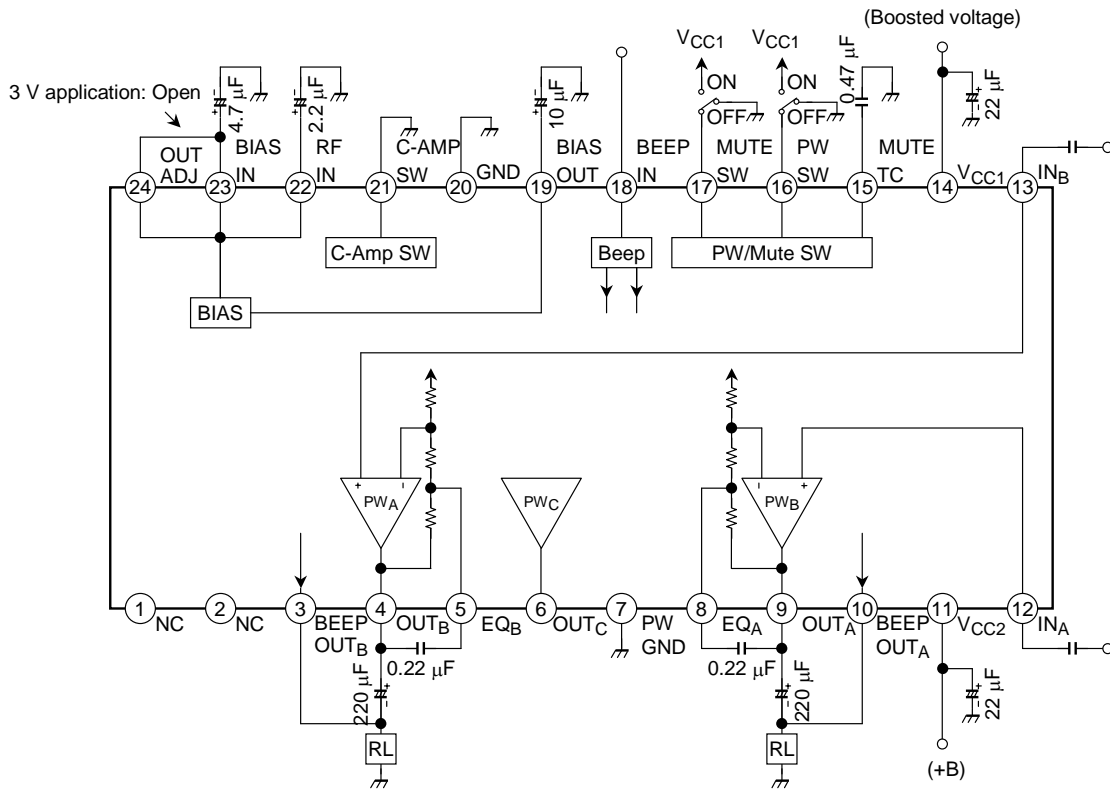

## Application Circuit 2 (1.5 V OCL Type)

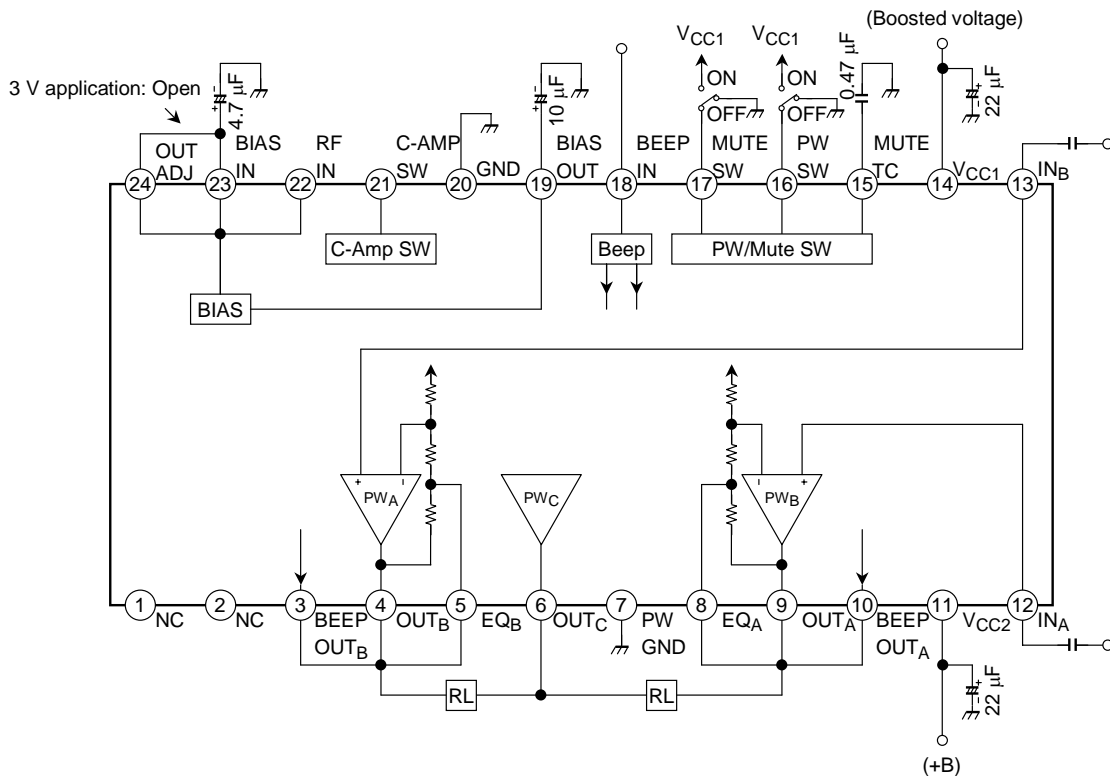

## Package Dimensions

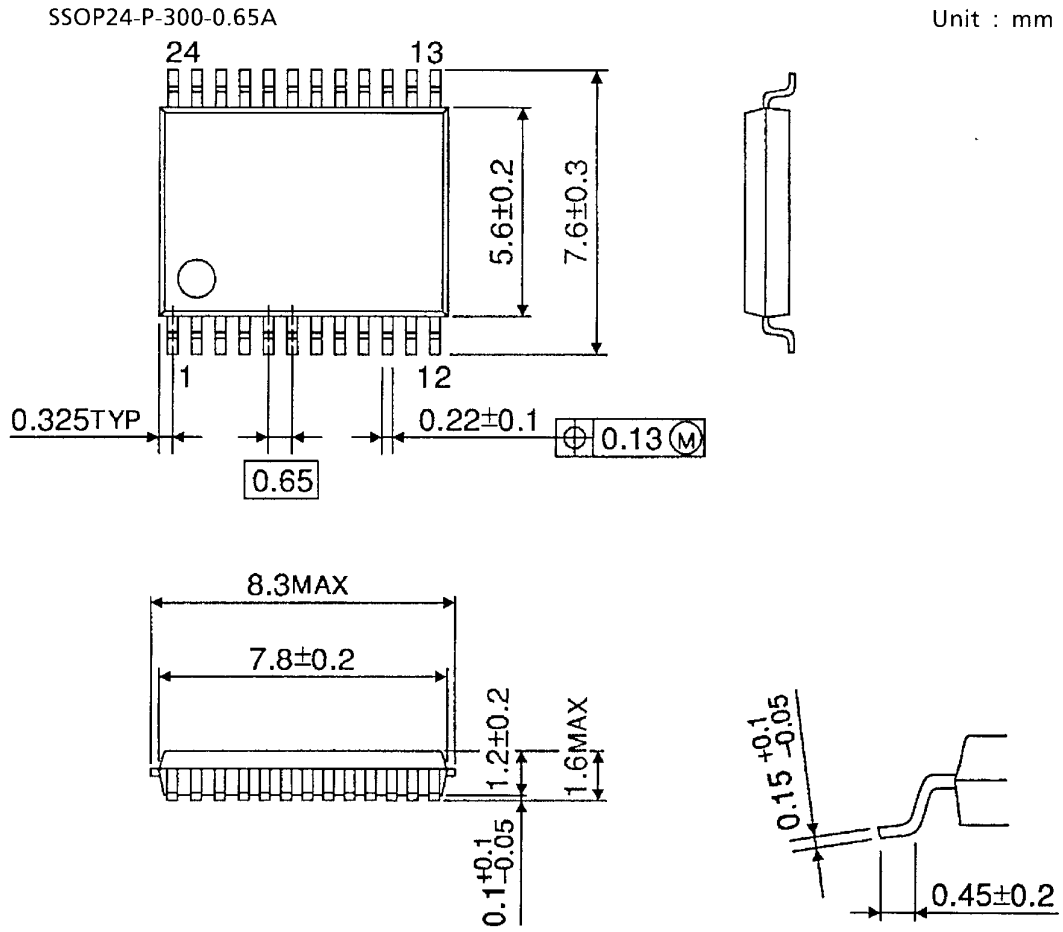

Weight: 0.14 g (typ.)

**RESTRICTIONS ON PRODUCT USE**

060116EBA

- The information contained herein is subject to change without notice. 021023\_D
- TOSHIBA is continually working to improve the quality and reliability of its products. Nevertheless, semiconductor devices in general can malfunction or fail due to their inherent electrical sensitivity and vulnerability to physical stress. It is the responsibility of the buyer, when utilizing TOSHIBA products, to comply with the standards of safety in making a safe design for the entire system, and to avoid situations in which a malfunction or failure of such TOSHIBA products could cause loss of human life, bodily injury or damage to property.  
In developing your designs, please ensure that TOSHIBA products are used within specified operating ranges as set forth in the most recent TOSHIBA products specifications. Also, please keep in mind the precautions and conditions set forth in the "Handling Guide for Semiconductor Devices," or "TOSHIBA Semiconductor Reliability Handbook" etc. 021023\_A
- The TOSHIBA products listed in this document are intended for usage in general electronics applications (computer, personal equipment, office equipment, measuring equipment, industrial robotics, domestic appliances, etc.). These TOSHIBA products are neither intended nor warranted for usage in equipment that requires extraordinarily high quality and/or reliability or a malfunction or failure of which may cause loss of human life or bodily injury ("Unintended Usage"). Unintended Usage include atomic energy control instruments, airplane or spaceship instruments, transportation instruments, traffic signal instruments, combustion control instruments, medical instruments, all types of safety devices, etc. Unintended Usage of TOSHIBA products listed in this document shall be made at the customer's own risk. 021023\_B
- The products described in this document shall not be used or embedded to any downstream products of which manufacture, use and/or sale are prohibited under any applicable laws and regulations. 060106\_Q
- The information contained herein is presented only as a guide for the applications of our products. No responsibility is assumed by TOSHIBA for any infringements of patents or other rights of the third parties which may result from its use. No license is granted by implication or otherwise under any patent or patent rights of TOSHIBA or others. 021023\_C
- The products described in this document are subject to the foreign exchange and foreign trade laws. 021023\_E

About solderability, following conditions were confirmed

- Solderability
  - (1) Use of Sn-37Pb solder Bath
    - solder bath temperature = 230°C
    - dipping time = 5 seconds
    - the number of times = once
    - use of R-type flux
  - (2) Use of Sn-3.0Ag-0.5Cu solder Bath
    - solder bath temperature = 245°C
    - dipping time = 5 seconds
    - the number of times = once
    - use of R-type flux