



LR1108

CMOS IC

1A FAST ULTRA LOW DROPOUT LINEAR REGULATOR

DESCRIPTION

The UTC **LR1108** operate from a +2.5V ~ +7.0V input supply as fast ultra low-dropout linear regulators. Wide output voltage range options are available. The fast response characteristic to make UTC **LR1108** suitable for low voltage microprocessor application. The low quiescent current operation and low dropout quality caused by the CMOS process.

The UTC **LR1108** has ultra low dropout voltage; 300mV at 600mA load current typically.

The ground pin current is typically 200uA at 1mA load current.

ERROR Flag: When the output voltage drops 10% below nominal value Error flag goes low.

Output Voltage Precision: Multiple output voltage options are available and ranging from 1.2V ~ 5.0V at room temperature with a guaranteed accuracy of ±1.5%, and ±3.0% when varying line, load and temperature.

FEATURES

- * Ultra low dropout voltage
- * Low ground pin current
- * 0.04% load regulation
- * The guaranteed output current is 1A DC
- * Output voltage accuracy ± 1.5%
- * **ERROR** flag indicates output status
- * Low output capacitor required
- * Overtemperature protection and overcurrent protection

ORDERING INFORMATION

Ordering Number		Package	Pin Assignment					Packing
Normal	Lead Free Plating		1	2	3	4	5	
LR1108-xx-AB3-A-R	LR1108L-xx-AB3-A-R	SOT-89	G	O	I	-	-	Tape Reel
LR1108-xx-AB3-C-R	LR1108L-xx-AB3-C-R	SOT-89	G	I	O	-	-	Tape Reel
LR1108-xx-AF5-R	LR1108L-xx-AF5-R	SOT-25	I	G	SD	ERROR	O	Tape Reel

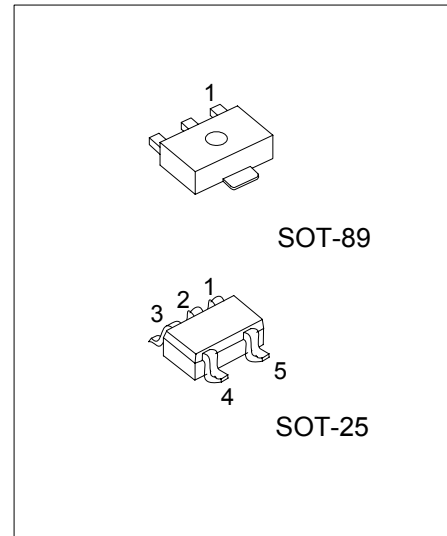

*Pb-free plating product number: LR1108L

<p>LR1108L-xx-AB3-A-R</p>	<p>(1)Packing Type (2)Package Type (3)Pin Assignment (4)Output Voltage Code (5)Lead Plating</p>	<p>(1) R: Tape Reel (2) AB3: SOT-89, AF5: SOT-25 (3) refer to Pin Assignment (4) xx: refer to Marking Information (5) L: Lead Free Plating, Blank: Pb/Sn</p>
---------------------------	---	--

MARKING INFORMATION

PACKAGE	VOLTAGE CODE	PIN CODE	PIN 1	PIN 2	PIN 3	PIN 4	PIN 5	MARKING
SOT-89	15 :1.5V 18:1.8V 25:2.5V 2J:2.85V 33:3.3V	A	GND	V_{OUT}	V_{IN}	-	-	
		C	GND	V_{IN}	V_{OUT}	-	-	
SOT-25		-	V_{IN}	GND	\overline{SD}	\overline{ERROR}	V_{OUT}	

PIN DESCRIPTION

Pin Description for SOT-89 Package

PIN CODE & NO.		PIN NAME	I/O	DESCRIPTION
A	C			
2	3	V_{OUT}	O	Output Voltage
1	1	GND		Ground
3	2	V_{IN}		Input Supply

Pin Description for SOT-25 Package

PIN NO.	PIN NAME	I/O	DESCRIPTION
1	V_{IN}		Input supply
2	GND		Ground
3	\overline{SD}	I	Shutdown LR1108 enable; when the \overline{SD} pin connects to GND will shutdown the LR1108; At normal operation, \overline{SD} must be tied to V_{DD} through a 10K Ω pull up resistor.
4	\overline{ERROR}	O	Error flag, active low; when the output dropout of regulation due to low input voltage, the LR1108 produces a logic low signal at the ERROR pin.
5	V_{OUT}	O	Output voltage

■ BLOCK DIAGRAM

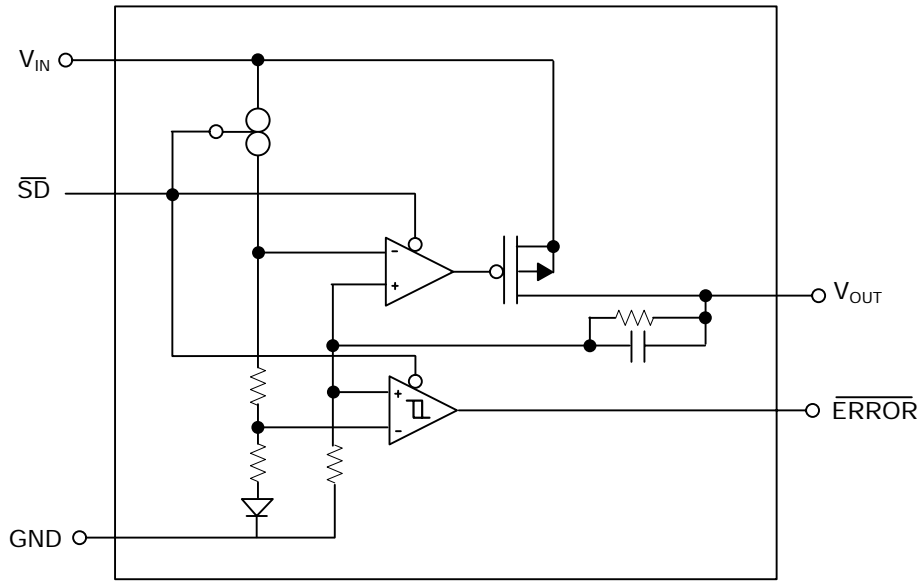

■ ABSOLUTE MAXIMUM RATINGS

PARAMETER	SYMBOL	RATINGS	UNIT
Input Voltage (Operating), (Note 10)	V_{IN}	2.5~7.0	V
Input Voltage (Survival)		-0.3~+7.5	V
Shutdown Input Voltage	$V_{IN(SHDN)}$	-0.3~ $V_{IN}+0.3$	V
Output Voltage (Survival), (Note 4), (Note 5)	V_{OUT}	-0.3~+7.5	V
I_{OUT} (Survival)		Short Circuit Protected	
Maximum Voltage for ERROR Pin		$V_{IN}+0.3$	V
Maximum Operating Current (DC)		1	A
Power Dissipation (Note 2)	P_D	Internally Limited	
Junction Temperature	T_J	+125	
Operating Temperature	T_{OPR}	-40~+125	
Storage Temperature	T_{STG}	-65~+150	

Note: Absolute maximum ratings are those values beyond which the device could be permanently damaged.

Absolute maximum ratings are stress ratings only and functional device operation is not implied.

■ ELECTRICAL CHARACTERISTICS

Limits in standard typeface are for $T_J = 25^\circ\text{C}$, and limits in **boldface type** apply over the full operating temperature range.

($T_J = 25^\circ\text{C}$, $V_{IN} = V_{O(NOM)} + 1\text{V}$, $I_L = 10\text{mA}$, $C_{OUT} = 2.2\mu\text{F}$, $V_{SD} = V_{IN}-0.3\text{V}$, unless otherwise specified.)

PARAMETER	SYMBOL	TEST CONDITIONS	MIN	TYP	MAX	UNIT
Output Voltage Tolerance (Note 6)	V_{OUT}	$0\text{mA} \leq I_L \leq 1\text{A}$ $V_{OUT} + 1 \leq V_{IN} < 7.0\text{V}$	-1.5 -3	0	+1.5 +3	%
Output Voltage Line Regulation (Note 6)	V_{OUT}	$V_{OUT} + 1\text{V} < V_{IN} < 7.0\text{V}$		0.05		%
Output Voltage Load Regulation (Note 6)	V_{OUT}/I_{OUT}	$10\text{mA} < I_L < 1\text{A}$		0.04		%
Dropout Voltage (Note 8)	V_D	$I_L = 1\text{A}$		300	500	mV
Ground Pin Current In Normal Operation Mode	I_{GND}	$I_L = 0\text{mA}$		200		uA
		$I_L = 1\text{A}$		300		
Peak Output Current	$I_{O(PEAK)}$	(Note 2)	600	800		mA
SHORT CIRCUIT PROTECTION						
Short Circuit Current	I_{SC}			2		A
OVER TEMPERATURE PROTECTION						
Shutdown Threshold	$T_{SHDN(THR)}$			165		
Thermal Shutdown Hysteresis	$T_{SHDN(HYS)}$			10		
SHUTDOWN INPUT						
Shutdown Threshold	V_{SHDN}	Output = High	$V_{IN}-0.3$	V_{IN}		V
		Output = Low		0	0.2	
Turn-off Delay	$t_{D(OFF)}$	$I_L = 1\text{A}$		20		μs
Turn-on Delay	$t_{D(ON)}$	$I_L = 1\text{A}$		25		μs
\overline{SD} Input Current	I_{SD}	$V_{SD} = V_{IN}$		1		nA
ERROR FLAG COMPARATOR						
ERROR Flag Saturation	$V_{EF(SAT)}$	$I_{SINK} = 100\mu\text{A}$		0.02	0.1	V
ERROR Flag Pin Leakage Current	$I_{I(LEAK)}$			1		nA
Threshold	V_T	(Note 7)	5	10	16	%
Threshold Hysteresis	V_{THR}	(Note 7)	2	5	8	%
Flag Reset Delay	t_D			1		μs
AC PARAMETERS						
Ripple Rejection	PSRR	$V_{IN} = V_{OUT} + 1.5\text{V}$ $C_{OUT} = 100\mu\text{F}$, $V_{OUT} = 3.3\text{V}$		60		dB
		$V_{IN} = V_{OUT} + 0.3\text{V}$ $C_{OUT} = 100\mu\text{F}$, $V_{OUT} = 3.3\text{V}$		40		
Output Noise Density	$\rho_{n(f)}$	$f = 120\text{Hz}$		0.8		μV
Output Noise Voltage	eN	BW = 10Hz – 100kHz		150		μVrms
		BW = 300Hz – 300kHz		100		

■ ELECTRICAL CHARACTERISTICS(Cont.)

- Note 1. Conditions for which the device is intended to be functional is indicated by operating ratings, but specific performance limits isn't be guaranteed. To make sure of specifications and test conditions, read Electrical Characteristics. Only for the test conditions listed the guaranteed specifications can be applied. When the device is not operated under the listed test conditions some performance characteristics may degrade.
2. Devices must be derated based on package thermal resistance at elevated temperatures.
 3. The most likely parametric norm represents at 25 .
 4. The LR1108 output must be diode-clamped to ground. If used in a dual-supply system where the regulator load is returned to a negative supply.
 5. Between the V_{IN} and V_{OUT} terminals the output PMOS structure contains a diode. This diode is reverse biased normally. If the voltage at the output terminal is forced to be higher than the voltage at the input terminal this diode will get forward biased. This diode can withstand 1Amp of peak current and 200mA of DC current typically.
 6. Output voltage line regulation is the change in output voltage from the nominal value which is due to change in the input line voltage. Which is defined as the change in output voltage from the nominal value due to change in load current is output voltage load regulation. The load regulation and line regulation specification include the typical number only. But, the limits for load and line regulation are included in the output voltage tolerance specification.
 7. Error Flag hysteresis and threshold are specified as regulated output voltage's percentage.
 8. At which the output drops 2% below the normal value dropout voltage is defined as the minimum input to output differential voltage. Only to output voltages of 2.5V and above dropout voltage specification applies. For output voltages below 2.5V, since the minimum input voltage is 2.5V, the drop-out voltage is nothing but the input to output differential.
 9. Specification has been tested at $-40 \leq T_J \leq 85$ cause under shutdown conditions the temperature rise of the device is negligible.
 10. The minimum operating V_{IN} value is equal to $[V_{OUT(NOM)} + V_{DROPOUT}]$ or 2.5V, just the greater.

■ TYPICAL APPLICATION CIRCUIT

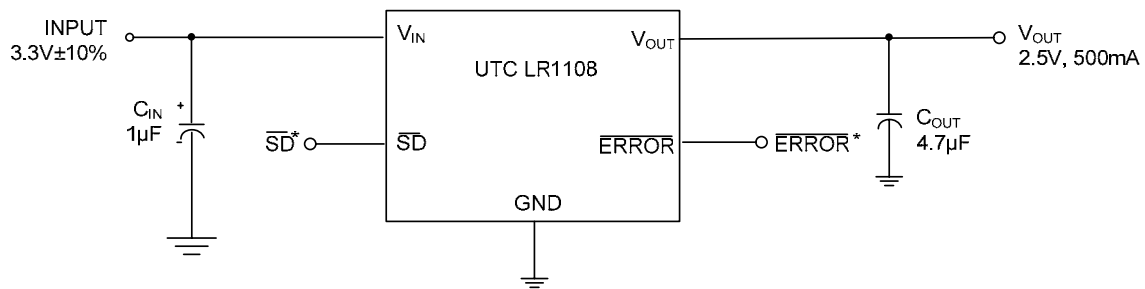

* \overline{SD} and \overline{ERROR} pins must be pulled high through a 10k Ω pull-up resistor. Connect the \overline{ERROR} pin to ground if this function is not used.

UTC assumes no responsibility for equipment failures that result from using products at values that exceed, even momentarily, rated values (such as maximum ratings, operating condition ranges, or other parameters) listed in products specifications of any and all UTC products described or contained herein. UTC products are not designed for use in life support appliances, devices or systems where malfunction of these products can be reasonably expected to result in personal injury. Reproduction in whole or in part is prohibited without the prior written consent of the copyright owner. The information presented in this document does not form part of any quotation or contract, is believed to be accurate and reliable and may be changed without notice.