

# NMOS multichannel detector head C5964 series

Incorporates a thermoelectrically-cooled NMOS linear image sensor



C5964 series is a family of multichannel detectors developed for spectrophotometry in the UV to near infrared range (up to 1000 nm). C5964 series device incorporates a thermoelectrically-cooled NMOS linear image sensor (S5930/S5931/S8382/S8383 series), low noise driver/amplifier circuit and highly stable temperature control circuit. It also operates from simple external signal inputs. The image sensor is cooled to a preset temperature ( $T_s=0\text{ }^\circ\text{C}$ ) as soon as the power is turned on. Should the cooler fail and the device overheat, the built-in protection circuit automatically shut off the power.

The housing is designed for compactness, yet offers good heat dissipation. Furthermore, mounting holes are provided on the front panel of the housing, permitting easy connection to a monochromator or other instruments

### Features

- Designed for use with a thermoelectrically-cooled NMOS linear image sensor (S5930 series, etc.)
- Built-in driver/amplifier and temperature control circuits
- Highly stable temperature control ensures a constant cooling temperature of  $T_s=0 \pm 0.05\text{ }^\circ\text{C}$  (at  $T_a=10$  to  $30\text{ }^\circ\text{C}$ )
- Operates from simple signal inputs
- High sensitivity and wide dynamic range
- Various models are available according to image sensor type

### Applications

- Multichannel spectrophotometry
- Spectrophotometer, colorimeter
- Optical spectrum analyzer
- Time-resolved photometry

### ■ Selection guide

C5964 series consists of the following models depending on the NMOS linear image sensor used.

NMOS multichannel detector head	NMOS linear image sensor				
	Type No.	Number of pixels	Pixel size [ $\mu\text{m}$ (H) $\times$ $\mu\text{m}$ (V)]	Effective active area [mm (H) $\times$ mm (V)]	Remark
C5964-0800	S5930-256S	256	50 $\times$ 2500	12.8 $\times$ 2.5	Standard type
C5964-0900	S5930-512S	512		25.6 $\times$ 2.5	
C5964-0910	S5931-512S	512	25 $\times$ 2500	12.8 $\times$ 2.5	
C5964-1010	S5931-1024S	1024		25.6 $\times$ 2.5	
C5964-0801	S8382-256S	256	50 $\times$ 2500	12.8 $\times$ 2.5	IR-enhanced type
C5964-0901	S8382-512S	512		25.6 $\times$ 2.5	
C5964-0911	S8383-512S	512	25 $\times$ 2500	12.8 $\times$ 2.5	
C5964-1011	S8383-1024S	1024		25.6 $\times$ 2.5	

■ Absolute maximum ratings

Parameter	Symbol	Value	Unit
Supply voltage (for digital circuitry)	+VD	-0.5 to +7	V
Supply voltage (for analog circuitry)	±VA	±18	V
Digital input voltage	-	VD	V
Operating temperature	Topr	+10 to +30	°C
Storage temperature	Tstg	0 to +50	°C

■ Electrical characteristics (Ta=25 °C, VD=+5 V, ±VA=±15 V, unless otherwise noted)

Parameter	Symbol	Min.	Typ.	Max.	Unit	
Digital input	High level	V <sub>IH</sub>	+2.0	-	+VD	V
	Low level	V <sub>IL</sub>	-0.5	-	+0.8	V
Master clock (CLK) pulse frequency	f <sub>CLK</sub>	-	-	375	kHz	
Video signal readout frequency	f <sub>v</sub>	-	-	f <sub>CLK</sub> /6	Hz	
Master start (start) pulse width	t <sub>st</sub>	1/f <sub>CLK</sub>	-	-	s	
Digital output	High level (I <sub>o</sub> = -6 mA)	V <sub>IH</sub>	+2.0	-	-	V
	Low level (I <sub>o</sub> =+6 mA)	V <sub>IL</sub>	-	-	+0.8	V
Power supply conditions: Rated voltage	Digital	+VD	+4.75	+5.0	+5.25	V
	Analog	±VA	±14.5	±15.0	±15.5	V
Power supply conditions: Current consumption	+5 Vdc <sup>*1</sup>	-	-	-	+2.0	A
	+15 Vdc	-	-	-	+100	mA
	-15 Vdc	-	-	-	-100	mA

\*1: Including the current consumption of the Peltier element incorporated in the NMOS linear image sensor (S5930 series, etc.)

■ Electrical and optical characteristics (Ta=25 °C, Ts=0 °C, VD=+5 V, ±VA=±15 V, unless otherwise noted)

Parameter	Built in sensors	Symbol	Min.	Typ.	Max.	Unit
Spectral response range		λ	-	200 to 1000	-	nm
Peak sensitivity wavelength	S5930/S5931 series	λ <sub>p</sub>	-	600	-	nm
	S8382/S8383 series		-	750	-	
Saturation output charge	S5930 series	Q <sub>sat</sub>	-	50	-	pC
	S5931 series		-	25	-	
	S8382 series		-	50	-	
	S8383 series		-	25	-	
Dark current	S5930 series	I <sub>D</sub>	-	0.009	0.03	pA/pixel
	S5931 series		-	0.004	0.01	
	S8382 series		-	0.009	0.03	
	S8383 series		-	0.004	0.01	
Photo response non-uniformity <sup>*2</sup>		PRNU	-	-	±3	%
Conversion gain	S5930 series	G <sub>c</sub>	-	0.2	-	V/pC
	S5931 series		-	0.4	-	
	S8382 series		-	0.2	-	
	S8383 series		-	0.4	-	

\*2: Use for "A" light source. 50 % of saturation, excluding first and last pixels.

■ Temperature controller specifications ( $T_a=25\text{ }^\circ\text{C}$ ,  $V_D=+5\text{ V}$ ,  $\pm V_A=\pm 15\text{ V}$ , unless otherwise noted)

Parameter <sup>*3</sup>	Symbol	Min.	Typ.	Max.	Unit
Cooling temperature	$T_s$	-1	0	+1	$^\circ\text{C}$
Temperature control range	$\Delta T_s$	-0.05	-	+0.05	$^\circ\text{C}$
Power dissipation of Peltier element	$P_p$	-	-	7	W
Cool down time to preset temperature	$t_o$	-	-	5	minute
Setting temperature for overheat protection	$T_o$	+40	-	-	$^\circ\text{C}$

\*3: Other functions include error display, automatic power off, and detection of electrical opens and shorts by the thermosensor.

■ Spectral response

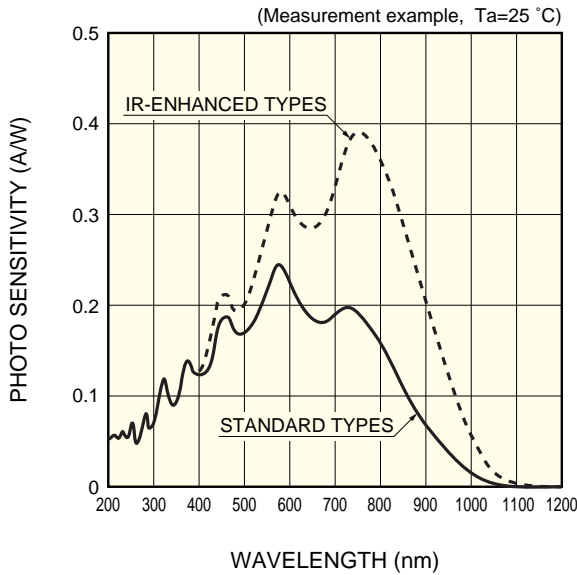

KMPDB0159EA

■ Block diagram of NMOS linear image sensor (S5930 series, etc.)

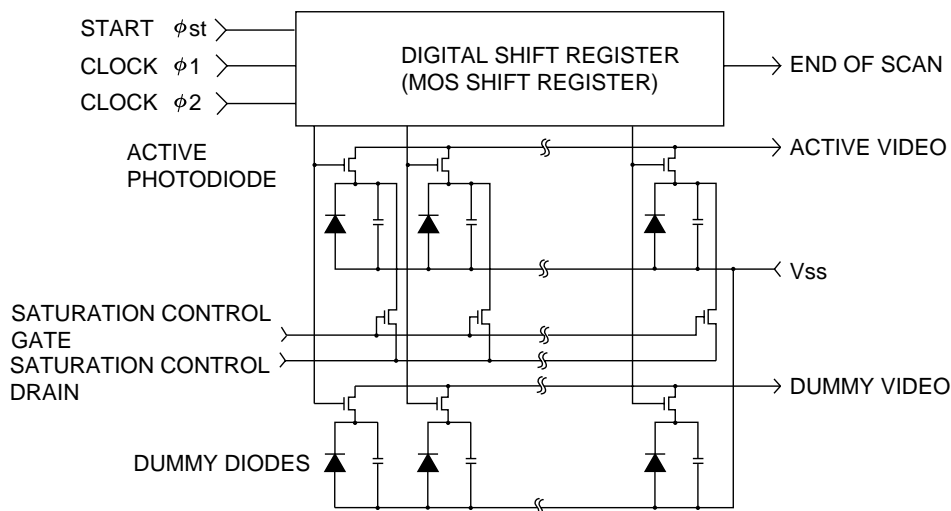

KMPDC0020EA

## Block diagram (C5964 series)

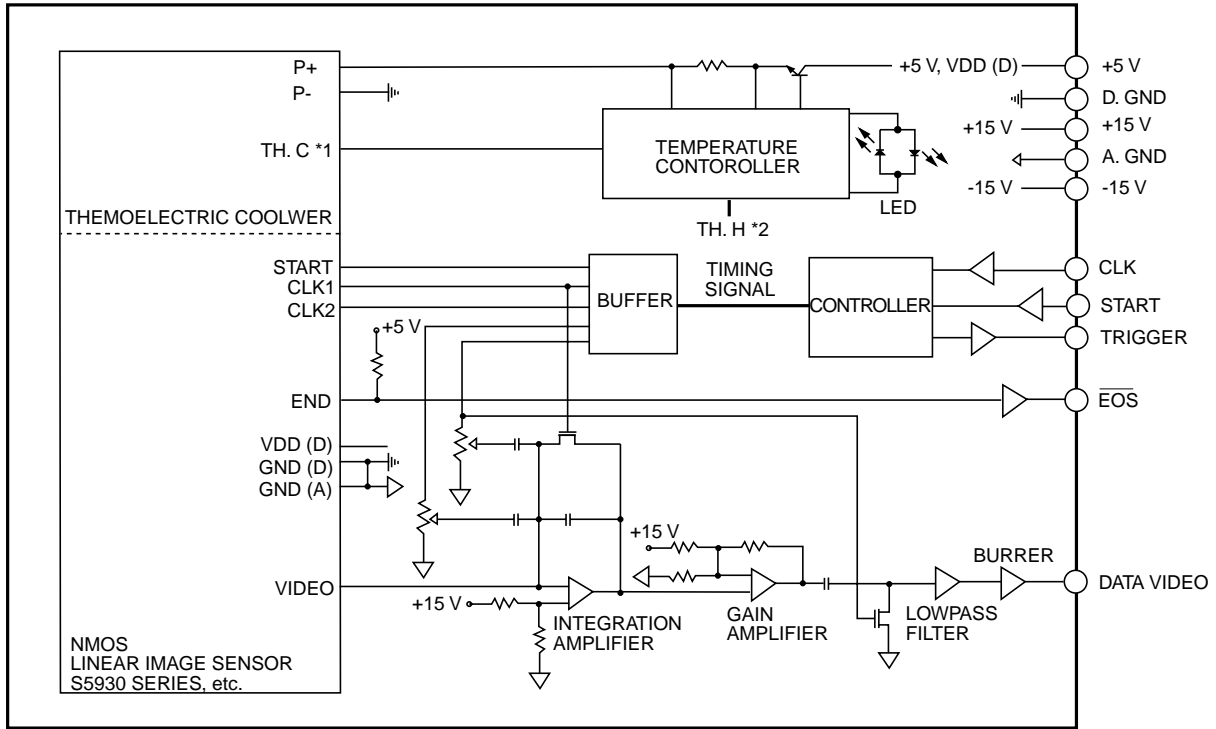

\*1: Thermistor incorporated in the image sensor. Used for temperature monitoring of the image sensor.  
 \*2: Thermistor mounted on the heatsink fins. Used for temperature monitoring of the heat radiating side.

KACCC0067EA

## Pulse timing chart

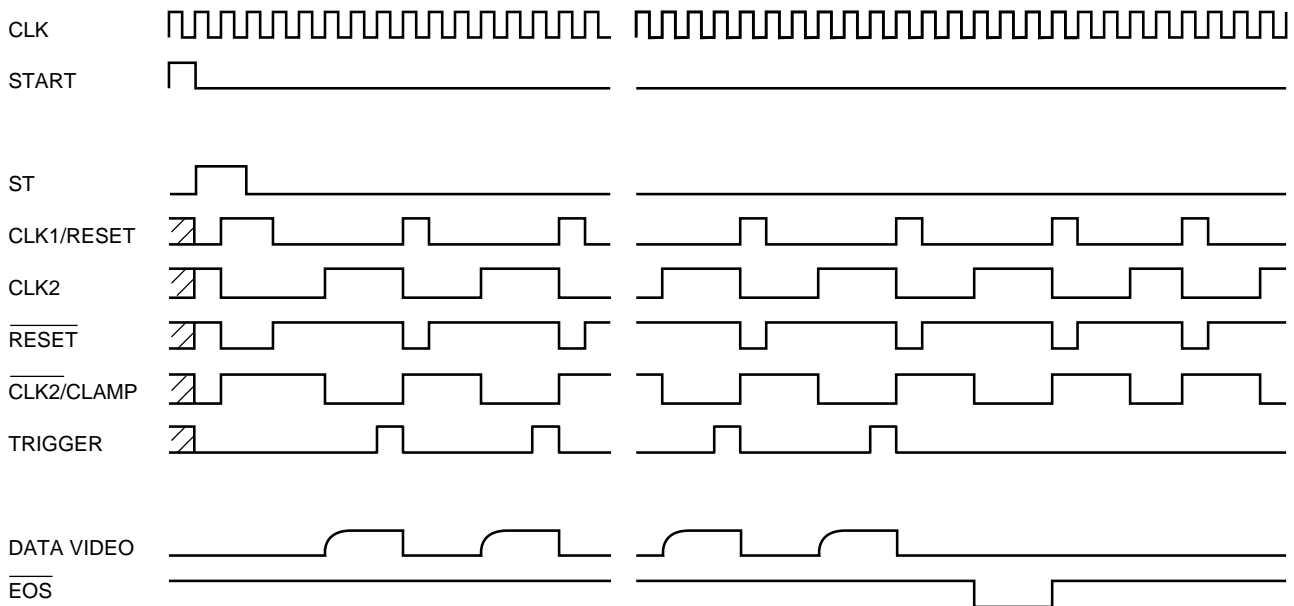

KACCC0068EA

## ■ Pin connection

PIN No.	Symbol	Description
1	NC	No connection.
2	Data video	Analog video output signal. Positive polarity.
3	VA1+ (+15 V)	Power supply for analog circuitry.
4	VA1- (-15 V)	Power supply for analog circuitry.
5	VD (+5 V, P+)	Power supply for digital circuitry. For the thermoelectric cooler in the NMOS linear image sensor.
6	Start	Digital input signal to initialize the circuit. HCMOS compatible. Positive logic. The start pulse interval determines the signal storage time of the sensor.
7	CLK	Digital input signal to specify the circuit operation. HCMOS compatible. Operates at the rising edge.
8	$\overline{\text{EOS}}$	Digital output signal to indicate the end of scan of the NMOS linear image sensor. HCMOS compatible. Negative logic.
9	A. GND	Analog ground.
10	A. GND	Analog ground.
11	NC	No connection.
12	D. GND (P-)	Digital ground. Power supply return of the thermoelectric cooler mounted in the NMOS linear image sensor.
13	D. GND	Digital ground.
14	D. GND	Digital ground.
15	Trigger	Digital output signal for A/D conversion. HCMOS compatible. Positive logic.

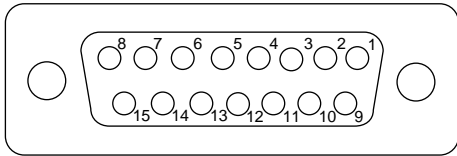

15-pin D-sub connector (socket type)

KACCC0069EA

## ■ Dimensional outline (unit: mm)

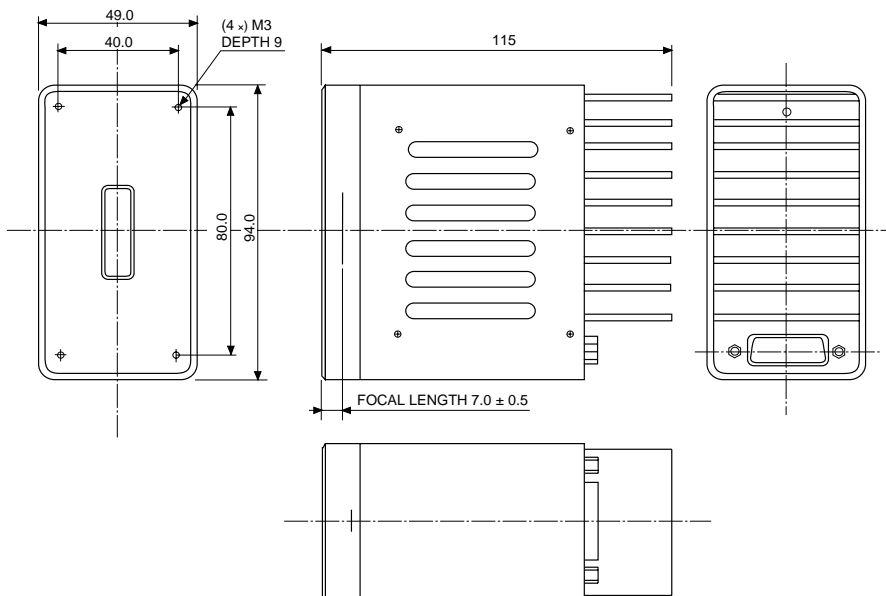

KACCA0053EA

## ■ Peripheral equipment for multichannel detectors

Hamamatsu provides a variety of peripheral equipment for NMOS multichannel detectors to facilitate high-precision measurement using computers. They include a data processing unit, and various interconnection cables. The figure below shows an example of connections to peripheral equipment, using a PC/AT compatible machine.

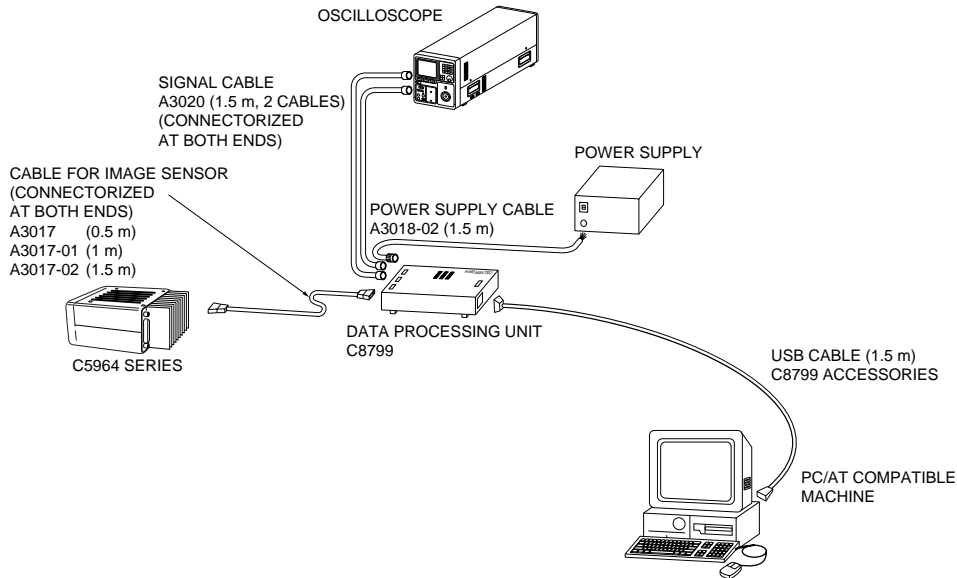

KACC0070EC

## ■ Handling precautions

C5964 series is a precision device, so use sufficient caution when handling it.

- Never disassemble or modify the device as this may cause an operating failure.
- Protect the device from shocks such as drops or impacts as these may cause breakage.
- Avoid storing the device in high temperature and high humidity locations for long periods of time.
- Never block the air vents provided on the top and side panels of this unit during operation. Blocking the air vents may cause overheating.
- When connecting to other equipment, check that the electrical specifications are matched.
- Never exceed the maximum ratings during operation.
- Observe the following precautions to obtain the fullest performance of device.
- Provide a proper shield to protect the device against external electromagnetic effects.  
Use of a shield cable is recommended.
- Use a power supply with minimum ripple and noise.
- Pay attention to prevent extraneous light from entering the device for accurate measurements.

**HAMAMATSU**

Information furnished by HAMAMATSU is believed to be reliable. However, no responsibility is assumed for possible inaccuracies or omissions. Specifications are subject to change without notice. No patent rights are granted to any of the circuits described herein. ©2005 Hamamatsu Photonics K.K.

HAMAMATSU PHOTONICS K.K., Solid State Division

1126-1 Ichino-cho, Higashi-ku, Hamamatsu City, 435-8558 Japan, Telephone: (81) 53-434-3311, Fax: (81) 53-434-5184, www.hamamatsu.com

U.S.A.: Hamamatsu Corporation: 360 Foothill Road, P.O.Box 6910, Bridgewater, N.J. 08807-0910, U.S.A., Telephone: (1) 908-231-0960, Fax: (1) 908-231-1218

Germany: Hamamatsu Photonics Deutschland GmbH: Arzbergerstr. 10, D-82211 Herrsching am Ammersee, Germany, Telephone: (49) 08152-3750, Fax: (49) 08152-2658

France: Hamamatsu Photonics France S.A.R.L.: 19, Rue du Saule Trapu, Parc du Moulin de Massy, 91882 Massy Cedex, France, Telephone: 33-(1) 69 53 71 00, Fax: 33-(1) 69 53 71 10

United Kingdom: Hamamatsu Photonics UK Limited: 2 Howard Court, 10 Tewin Road, Welwyn Garden City, Hertfordshire AL7 1BW, United Kingdom, Telephone: (44) 1707-294888, Fax: (44) 1707-325777

North Europe: Hamamatsu Photonics Norden AB: Smidesvägen 12, SE-171 41 Solna, Sweden, Telephone: (46) 8-509-031-00, Fax: (46) 8-509-031-01

Italy: Hamamatsu Photonics Italia S.R.L.: Strada della Moia, 1/E, 20020 Arese, (Milano), Italy, Telephone: (39) 02-935-81-733, Fax: (39) 02-935-81-741