

UT7R995 & UT7R995C RadClock™

RadHard 2.5V/3.3V 200MHz High-Speed Multi-phase PLL Clock Buffer

Datasheet
February, 2007



FEATURES:

- ❑ +3.3V Core Power Supply
- ❑ +2.5V or +3.3V Clock Output Power Supply
 - Independent Clock Output Bank Power Supplies
- ❑ Output frequency range: 6 MHz to 200 MHz
- ❑ Bank pair output-output skew < 100 ps
- ❑ Cycle-cycle jitter < 50 ps
- ❑ 50% ± 2% maximum output duty cycle at 100MHz
- ❑ Eight LVTTTL outputs with selectable drive strength
- ❑ Selectable positive- or negative-edge synchronization
- ❑ Selectable phase-locked loop (PLL) frequency range and lock indicator
- ❑ Phase adjustments in 625 to 1300 ps steps up to ± 7.8 ns
- ❑ (1-6,8,10,12) x multiply and (1/2,1/4) x divide ratios
- ❑ Compatible with Spread-Spectrum reference clocks
- ❑ Power-down mode
- ❑ Selectable reference input divider
- ❑ Radiation performance
 - Total-dose tolerance: 100 krad (Si)
 - SEL Immune to a LET of 109 MeV-cm²/mg
 - SEU Immune to a LET of 109 MeV-cm²/mg
- ❑ Military temperature range: -55°C to +125°C
- ❑ Extended industrial temp: -40°C to +125°C
- ❑ Packaging options:
 - 48-Lead Ceramic Flatpack
- ❑ Standard Microcircuit Drawing: 5962-05214
 - QML-Q and QML-V compliant part

INTRODUCTION:

The UT7R995/UT7R995C is a low-voltage, low-power, eight-output, 6-to-200 MHz clock driver. It features output phase programmability which is necessary to optimize the timing of high-performance microprocessor and communication systems.

The user programs both the frequency and the phase of the output banks through nF[1:0] and DS[1:0] pins. The adjustable phase feature allows the user to skew the outputs to lead or lag the reference clock. Connect any one of the outputs to the feedback input to achieve different reference frequency multiplication and division ratios.

The devices also feature split output bank power supplies that enable banks 1 & 2, bank 3, and bank 4 to operate at a different power supply levels. The ternary PE/HD pin controls the synchronization of output signals to either the rising or the falling edge of the reference clock and selects the drive strength of the output buffers. The UT7R995 and UT7R995C both interface to a digital clock while the UT7R995C will also interface to a quartz crystal.

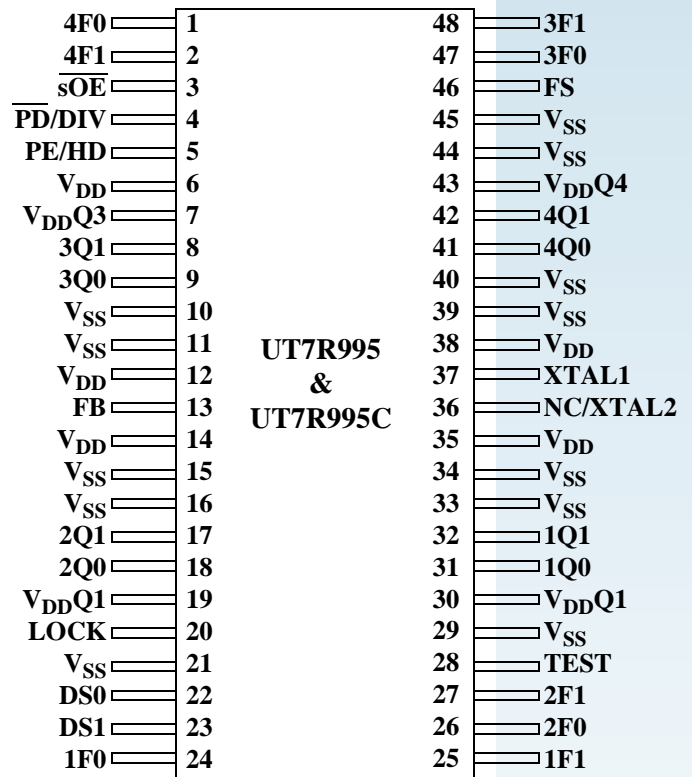

Figure 1. 48-Lead Ceramic Flatpack Pin Description

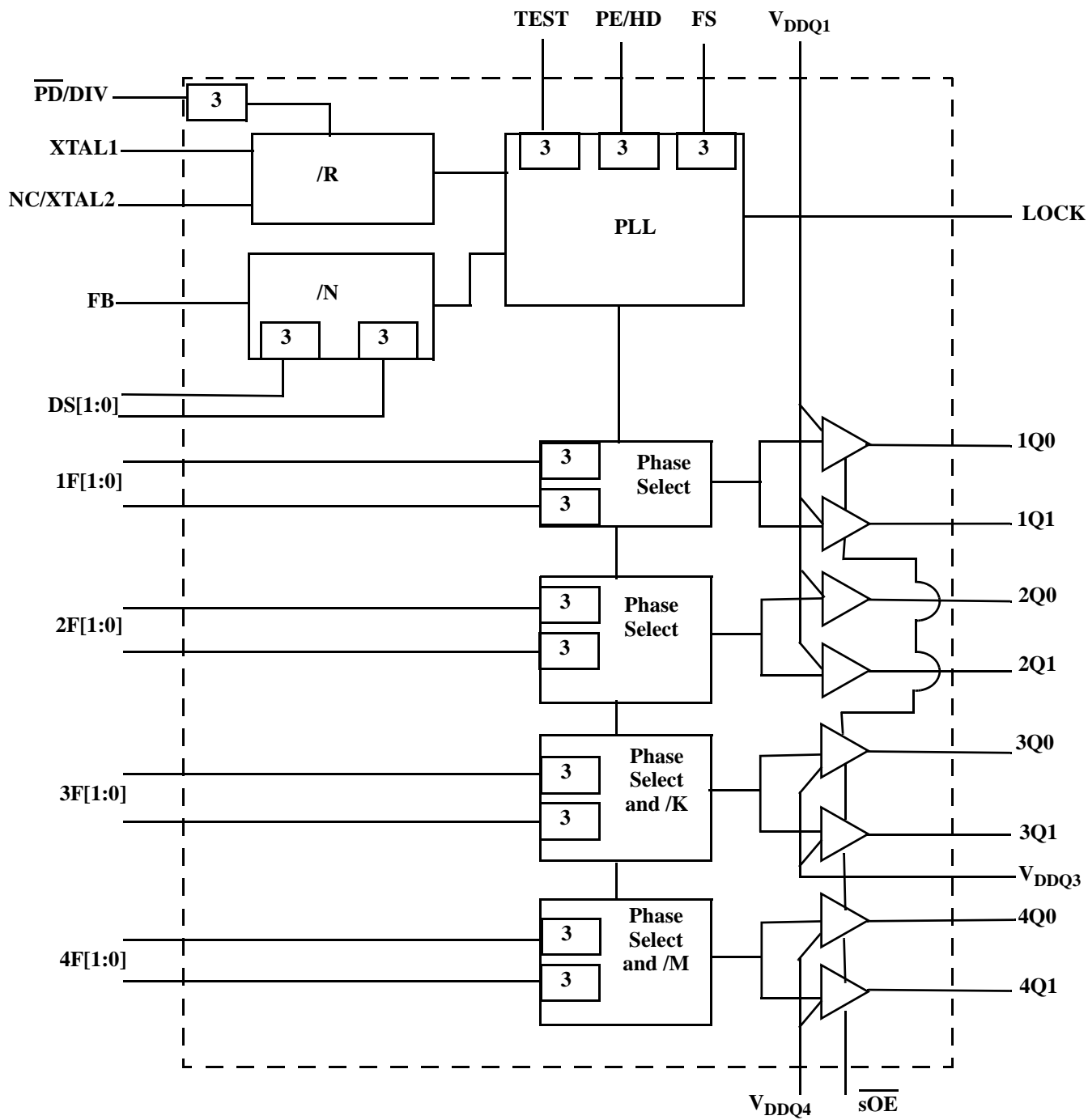

Figure 2. UT7R995 & UT7R995C Block Diagram

1.0 DEVICE CONFIGURATION:

The outputs of the UT7R995/C can be configured to run at frequencies ranging from 6 MHz to 200 MHz. Each output bank has the ability to run at separate frequencies and with various phase skews. Furthermore, numerous clock division and multiplication options exist.

The following discussion and list of tables will summarize the available configuration options for the UT7R995/C. Tables 1 through 12, are relevant to the following configuration discussions.

- Table 1. Feedback Divider Settings (N-factor)**
- Table 2. Reference Divider Settings (R-Factor)**
- Table 3. Output Divider Settings - Bank 3 (K-factor)**
- Table 4. Output Divider Settings - Bank 4 (M-Factor)**
- Table 5. Frequency Divider Summary**
- Table 6. Calculating Output Frequency Settings**
- Table 7. Frequency Range Select**
- Table 8. Multiplication Factor (MF) Calculation**
- Table 9. Signal Propagation Delays in Various Media**
- Table 10: Output Skew Settings**
- Table 11. PE/HD Settings**
- Table 12. Power Supply Constraints**

1.1 Divider Configuration Settings:

The feedback input divider is controlled by the 3-level DS[1:0] pins as indicated in Table 1 and the reference input divider is controlled by the 3-level $\overline{\text{PD}}/\text{DIV}$ pin as indicated in Table 2. Although the Reference divider will continue to operate when the UT7R995/C is in the standard TEST mode of operation, the Feedback Divider will not be available.

Table 1: Feedback Divider Settings (N-factor)

DS[1:0]	Feedback Input Divider - (N)	Permitted Output Divider (K or M) Connected to FB
LL	2	1 or 2
LM	3	1
LH	4	1, 2, or 4
ML	5	1 or 2
MM	1	1, 2, or 4
MH	6	1 or 2
HL	8	1 or 2
HM	10	1
HH	12	1

Table 2: Reference Divider Settings (R-factor)

$\overline{\text{PD}}/\text{DIV}$	Operating Mode	Reference Input Divider - (R)
LOW ¹	Powered Down	Not Applicable
MID	Normal Operation	2
HIGH	Normal Operation	1

Notes:

1. When $\overline{\text{PD}}/\text{DIV}$ = LOW, the device enters power-down mode.

In addition to the reference and feedback dividers, the UT7R995/C includes output dividers on Bank 3 and Bank 4, which are controlled by 3F[1:0] and 4F[1:0] as indicated in Tables 3 and 4, respectively.

Table 3: Output Divider Settings - Bank 3 (K-factor)

3F(1:0)	Bank 3 Output Divider - (K)
LL	2
HH	4
Other ¹	1

Notes:

1. These states are used to program the phase of the respective banks. Please see Equation 1 along with Tables 8 and 10.

Table 4: Output Divider Settings - Bank 4 (M-factor)

4F[1:0]	Bank 4 Output Divider (M)
LL	2
Other ¹	1

Notes:

1. These states are used to program the phase of the respective banks. Please see Equation 1 along with Tables 8 and 10.

Each of the four divider options and their respective settings are summarized in Table 5. By applying the divider options in Table 5 to the calculations shown in Table 6, the user determines the proper clock frequency for every output bank.

Table 5: Frequency Divider Summary

Division Factors	Available Divider Settings
N	1, 2, 3, 4, 5, 6, 8, 10, 12
R	1, 2
K	1, 2, 4
M	1, 2

Table 6: Calculating Output Frequency Settings

Configuration	Output Frequency		
Clock Output Connected to FB	1Q[1:0] ¹ and 2Q[1:0] ¹	3Q[1:0]	4Q[1:0]
1Qn or 2Qn	$(N/R) * f_{XTAL}$	$(N/R) * (1/K) * f_{XTAL}$	$(N/R) * (1/M) * f_{XTAL}$
3Qn	$(N/R) * K * f_{XTAL}$	$(N/R) * f_{XTAL}$	$(N/R) * (K/M) * f_{XTAL}$
4Qn	$(N/R) * M * f_{XTAL}$	$(N/R) * (M/K) * f_{XTAL}$	$(N/R) * f_{XTAL}$

Notes:

1. These outputs are undivided copies of the VCO clock. Therefore, the formulas in this column can be used to calculate the nominal VCO operating frequency (f_{NOM}) at a given reference frequency (f_{XTAL}) and the divider and feedback configuration. The user must select a configuration and a reference frequency that will generate a VCO frequency that is within the range specified by FS pin. Please see Table 7.

1.2 Frequency Range and Skew Selection:

The PLL in the UT7R995/C operates within three nominal frequency ranges. Depending upon the desired PLL operating frequency, the user must define the state of the ternary FS control pin. Table 7 defines the required FS selections based upon the nominal PLL operating frequency ranges. Because the clock outputs on Bank 1 and Bank 2 do not include a divider option, they will always reflect the current frequency of the PLL. Reference the first column of equations in Table 6 to calculate the value of f_{NOM} for any given feedback clock.

Table 7: Frequency Range Select

FS	Nominal PLL Frequency Range (f_{NOM})
L	24 to 50 MHz
M	48 to 100MHz
H	96 to 200 MHz

Selectable output skew is in discrete increments of time unit (t_U). The value of t_U is determined by the FS setting and the PLL’s operating frequency (f_{NOM}). Use the following equation to calculate the time unit (t_U):

Equation 1.
$$t_U = \frac{1}{(f_{NOM} * MF)}$$

The f_{NOM} term, which is calculated with the help of Table 6, must be compatible with the nominal frequency range selected by the FS signal as defined in Table 7. The multiplication factor (MF), also determined by FS, is shown in Table 8. The UT7R995/C output skew steps have a typical accuracy of +/- 15% of the calculated time unit (t_U).

After calculating the time unit (t_U) based on the nominal PLL frequency (f_{NOM}) and multiplication factor (MF), the circuit designer plans routing requirements of each clock output and its respective destination receiver. With an understanding of signal propagation delays through a conductive medium (see Table 9), the designer specifies trace lengths which ensure a signal propagation delay that is equal to one of the t_U multiples show in Table 10. For each output bank, the t_U skew factors are selected with the tri-level, bank-specific, nF[1:0] pins.

Table 8: MF Calculation

FS	MF	f_{NOM} examples that result in a t_U of 1.0ns
L	32	31.25 MHz
M	16	62.5 MHz
H	8	125 MHz

Table 9: Signal Propagation Delays in Various Media

Medium	Propagation Delay (ps/inch)	Dielectric Constant
Air (Radio Waves)	85	1.0
Coax. Cable (75% Velocity)	113	1.8
Coax. Cable (66% Velocity)	129	2.3
FR4 PCB, Outer Trace	140 - 180	2.8 - 4.5
FR4 PCB, Inner Trace	180	4.5
Alumina PCB, Inner Trace	240 - 270	8 - 10

Table 10: Output Skew Settings⁴

nF[1:0]	Skew 1Q[1:0], 2Q[1:0]	Skew 3Q[1:0]	Skew 4Q[1:0]
LL ^{1,2}	-4t _U	Divide by 2	Divide by 2
LM	-3t _U	-6t _U	-6t _U
LH	-2t _U	-4t _U	-4t _U
ML	-1t _U	-2t _U	-2t _U
MM	Zero Skew	Zero Skew	Zero Skew
MH	+1t _U	+2t _U	+2t _U
HL	+2t _U	+4t _U	+4t _U
HM	+3t _U	+6t _U	+6t _U
HH ²	+4t _U	Divide by 4	Inverted ³

Notes:

- nF[1:0] = LL disables bank specific outputs if TEST=MID and sOE = HIGH.
- When TEST=MID or HIGH, the Divide-by-2, Divide-by-4, and Inversion-options function as defined in Table 9.
- When 4Q[1:0] are set to run inverted (4F[1:0] = HH), sOE disables these outputs HIGH when PE/HD = HIGH or MID, sOE disables them LOW when PE/HD = LOW.
- Skew accuracy is within +/- 15% of n*t_U where "n" is the selected number of skew steps. Supplied as a design limit, but not tested or guaranteed.

A graphical summary of Table 10 is shown in Figure 3. The drawing assumes that the FB input is driven by a clock output programmed with zero skew. Depending upon the state of the nF[1:0] pins the respective clocks will be skewed, divided, or inverted relative to the feedback output as shown in Figure 3.

1.3 Output Drive, Synchronization, and Power Supplies:

The UT7R995/C employs flexible output buffers providing the user with selectable drive strengths, independent power supplies, and synchronization to either edge of the reference input. Using the 3-level PE/HD pin, the user selects the reference edge synchronization and the output drive strength for all clock outputs. The options for edge synchronization and output drive strength selected by the PE/HD pin are listed in Table 11.

Table 11: PE/HD Settings

PE/HD	Synchronization	Output Drive Strength ¹
L	Negative	Low Drive
M	Positive	High Drive
H	Positive	Low Drive

Notes:

- Please refer to "DC Parameters" section for I_{OH}/I_{OL} specifications.

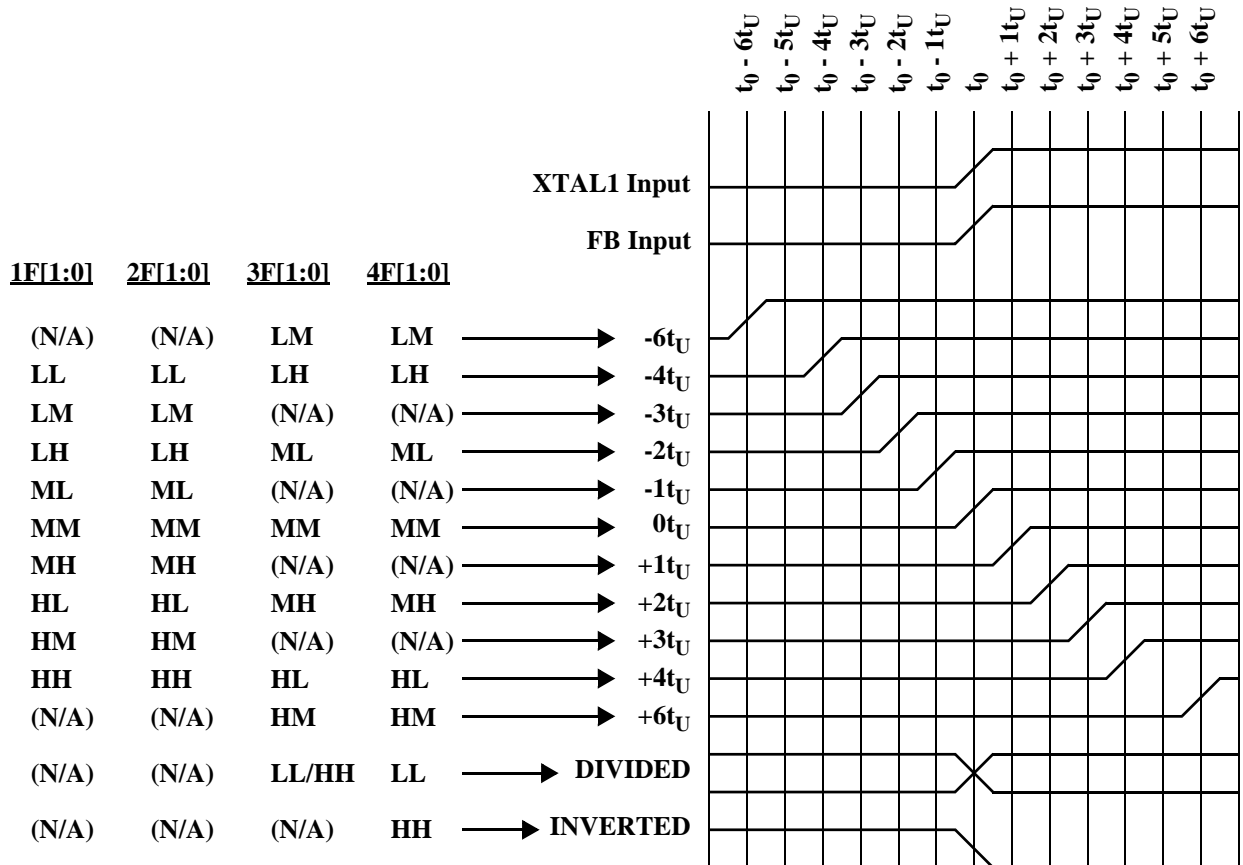

Figure 3. Typical Outputs with FB Connected to a Zero-Skewed Output

When the outputs are configured for low drive operation, they will provide a minimum 12mA of drive current regardless of the selected output power supply. If the outputs are configured for high drive operation, they will provide a minimum 24mA of drive current under a 3.3V power supply and 20mA when powered from a 2.5V supply.

The UT7R995/C features split power supply buses for Banks 1 and 2, Bank 3, and Bank 4. These independent power supplies enable the user to obtain both 3.3V and 2.5V output signals from one UT7R995/C device. The core power supply (V_{DD}) must run from a 3.3V power supply. Table 12 summarizes the various power supply options available with the UT7R995/C.

Table 12: Power Supply Constraints¹

V_{DD}	V_{DDQ1}	V_{DDQ3}	V_{DDQ4}
3.3V	3.3V or 2.5V	3.3V or 2.5V	3.3V or 2.5V

Notes:

- $V_{DDQ1/3/4}$ must not be set at a level higher than that of V_{DD} .

1.4 Reference Clock Interfaces

When an external, LVCMOS/LVTTL, digital clock is used to drive the UT7R995 and UT7R995C, the reference clock signal should drive the XTAL1 input of the RadClock, while the XTAL2 output should be left unconnected (see Figure 4). **Note, for the UT7R995 only, the XTAL2 pin is defined as a no-connect.**

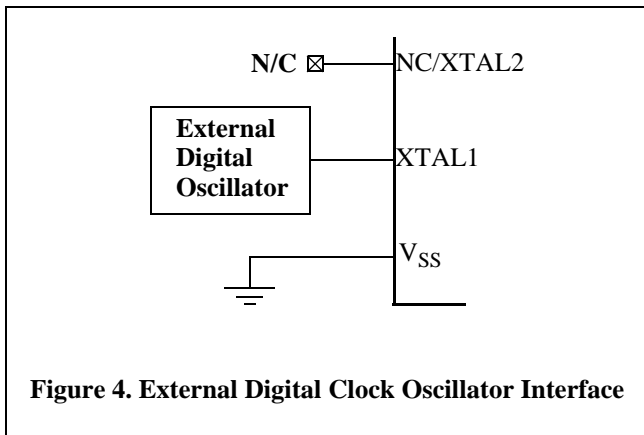
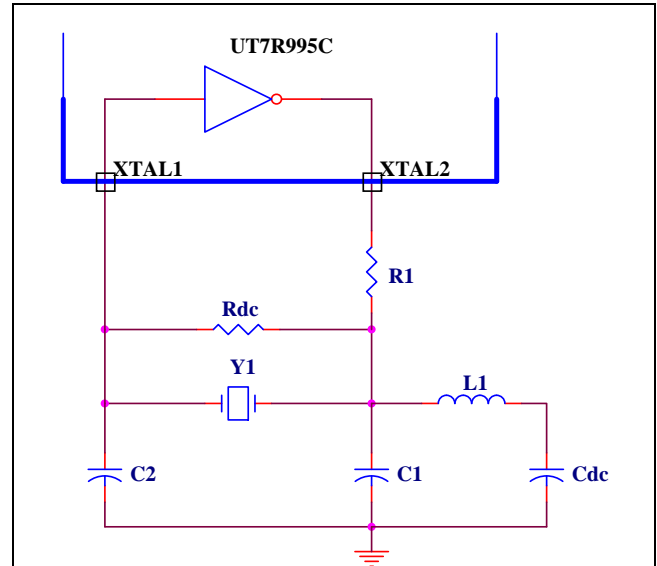

Figure 4. External Digital Clock Oscillator Interface

In addition to a digital clock reference, the UT7R995C can interface to a quartz crystal. When interfacing to a quartz crystal, XTAL1 and XTAL2 are the input and output, respectively, of an inverting amplifier within the RadClock. This inverting amplifier provides the initial 180° phase shift of the reference clock whose frequency, and subsequent 180° phase shift, is set by the quartz crystal and its surrounding RLC network. Figure 5 shows a typical pierce-oscillator with tank-circuit that will support reliable startup of fundamental and odd-harmonic, AT-cut, quartz crystals.



Fundamental Frequency Pierce Crystal Oscillator

$R_{dc} = \sim 10M\Omega$; $L1 = \text{Not Used}$; $C_{dc} = \text{Not Used}$

$C2$ is used to tune the circuit for stable oscillation. Typical values for $C2$ range from 30pF to 50pF.

$R1$ and $C1$ are selected to create a time constant that facilitates the fundamental frequency (f_F) of the quartz crystal as defined in equation 2.

$$\text{Equation 2. } f_F = \frac{1}{(2\pi * R1 * C1)}$$

As an example, selecting a value of 100Ω for $R1$ and 80pF for $C1$ would facilitate the reliable operation of a 20MHz, AT-cut, quartz crystal.

Higher Frequency Pierce Crystal Oscillator

$R_{dc} = \sim 10M\Omega$; $C_{dc} = \sim 1.5nF$; $C2 = \text{Tuning capacitor similar to prior example}$

$R1$ and $C1$ are selected to create a time constant that facilitates the overtone frequency (f_{OT}) of the quartz crystal as shown in equation 3.

$$\text{Equation 3. } f_{OT} = \frac{1}{(2\pi * R1 * C1)}$$

Additionally, $L1$ is selected such that its relationship with $C1$ facilitates a frequency falling between the fundamental frequency (f_F) and the specified overtone frequency (f_{OT}) of the quartz crystal as shown in equation 4.

$$\text{Equation 4. } f_M = \left(\frac{1}{2\pi * \sqrt{L1 * C1}} \right)$$

As an example, selecting the following component values will result in a 50MHz Pierce Crystal Oscillator based upon an 3rd overtone, AT-cut, quartz crystal having a fundamental frequency of 16.6666MHz.

$R_{dc} = 10M\Omega$; $C_{dc} = 1.5nF$; $C2 = 30pF$;
 $R1 = 50\Omega$; $C1 = 55pF$; $L1 = 300nH$;
 $f_F = 16.6666MHz$; $f_{OT} = 50MHz$

Figure 5. Pierce Crystal Oscillator with Tank Circuit

2.0 RADIATION HARDNESS

Table 13: Radiation Hardness Design Specifications

Parameter	Limit	Units
Total Ionizing Dose (TID)	>1E6	rads(Si)
Single Event Latchup (SEL) ^{1,2}	>109	MeV-cm ² /mg
Onset Single Event Upset (SEU) LET Threshold ^{3,4}	>109	MeV-cm ² /mg
Onset Single Event Transient (SET) LET Threshold (@ 50MHz; FS=L) ⁵	>74	MeV-cm ² /mg
Neutron Fluence	1.0E14	n/cm ²

Notes:

1. The UT7R995/C are latchup immune to particle LETs >109 MeV-cm²/mg.
2. Worst case temperature and voltage of T_C = +125°C, V_{DD} = 3.6V, V_{DD}Q1/Q3/Q4 = 3.6V for SEL.
3. Worst case temperature and voltage of T_C = +25°C, V_{DD} = 3.0V, V_{DD}Q1/Q3/Q4 = 3.0V for SEU.
4. All SEU data specified in this datasheet is based on the storage elements used in the UT7R995/C.
5. For characterization data on the UT7R995/C SET performance over allowable operating ranges, please contact the factory.

3.0 PIN DESCRIPTION

Flatpack Pin No.	Name	I/O	Type	Description
37	XTAL1	I	LVTTL	Primary reference clock input. When interfacing a single-ended reference clock to the UT7R995 or UT7R995C, this input must be driven by an LVTTL/LVCMOS clock source. If a quartz crystal is used as the reference clock source (UT7R995C only), the second pin on the crystal must be connected to XTAL2. If a singled ended reference clock is supplied to this pin, then XTAL2 should be left unconnected.
36	N/C	--	--	No Connect. UT7R995 Only.
	XTAL2	O	N/A	Feedback output from the on-board crystal oscillator. When a crystal is used to supply the reference clock for the UT7R995C, this pin must be connected to the second terminal of the quartz crystal. If a single-ended reference clock is supplied to XTAL1, then this output should be left unconnected.
13	FB	I	LVTTL	Feedback input for the PLL. When FB is not driven by an active clock output the PLL will run to its maximum frequency, unless the device is placed in power-down.
28	TEST ¹	I	3-Level	Built-in test control signal. When Test is set to the MID or HIGH level, it disables the PLL and the XTAL1 reference frequency is driven to all outputs (except for the conditions described in note 1). Set Test LOW for normal operation.

Flatpack Pin No.	Name	I/O	Type	Description																
3	$\overline{\text{sOE}}$	I	LVTTL	<p>Synchronous Output Enable. The $\overline{\text{sOE}}$ input is used to synchronously enable/disable the output clocks. Each clock output that is controlled by the $\overline{\text{sOE}}$ pin is synchronously enabled/disabled by the individual output clock. When HIGH, $\overline{\text{sOE}}$ disables all clocks except 2Q0 and 2Q1. When disabled, 1Q0, 1Q1, 3Q0, and 3Q1 will always enter a LOW state when PE/HD is MID or HIGH, and they will disable into a HIGH state when PE/HD is LOW.</p> <p>The disabled state of 4Q0 and 4Q1 is dependent upon the state of PE/HD and 4F[1:0]. The following table illustrates the disabled state of bank 4 outputs as they are controlled by the state of PE/HD and 4F[1:0].</p> <table border="1"> <thead> <tr> <th><u>PE/HD</u></th> <th><u>4F[1:0]*</u></th> <th><u>4Q0</u></th> <th><u>4Q1</u></th> </tr> </thead> <tbody> <tr> <td>LOW</td> <td>HH</td> <td>LOW</td> <td>LOW</td> </tr> <tr> <td>MID</td> <td>HH</td> <td>HIGH</td> <td>HIGH</td> </tr> <tr> <td>HIGH</td> <td>HH</td> <td>HIGH</td> <td>HIGH</td> </tr> </tbody> </table> <p>*All other combinations of 4F[1:0] will result in 4Q0 and 4Q1 disabling into a LOW state when PE/HD is MID or HIGH, and they will disable into a HIGH state when PE/HD is LOW.</p> <p>When TEST is held at the MID level and $\overline{\text{sOE}}$ is HIGH, the nF[1:0] pins act as individual output enable/disable controls for each output bank, excluding bank 2. Setting both nF[1:0] signals LOW disables the corresponding output bank.</p> <p>Set $\overline{\text{sOE}}$ LOW to place the UT7R995/C RadClock™ outputs into their normal operating modes.</p>	<u>PE/HD</u>	<u>4F[1:0]*</u>	<u>4Q0</u>	<u>4Q1</u>	LOW	HH	LOW	LOW	MID	HH	HIGH	HIGH	HIGH	HH	HIGH	HIGH
<u>PE/HD</u>	<u>4F[1:0]*</u>	<u>4Q0</u>	<u>4Q1</u>																	
LOW	HH	LOW	LOW																	
MID	HH	HIGH	HIGH																	
HIGH	HH	HIGH	HIGH																	
1, 2, 24, 25, 26, 27, 47, 48	nF[1:0]	I	3-Level	<p>Output divider and phase skew selection for each output bank. Please see Tables 3, 4, 5, 6, and 9 for a complete explanation of the nF[1:0] control functions and their effects on output frequency and skew.</p>																
46	FS	I	3-Level	<p>VCO operating frequency range selection. Please see Tables 7 and 8.</p>																
8, 9, 17, 18, 31, 32, 41, 42	nQ[1:0]	O	LVTTL	<p>Four clock banks of two outputs each. Please see Table 6 for frequency settings and Table 9 for skew settings.</p>																
22, 23	DS[1:0]	I	3-Level	<p>Feedback input divider selection. Please see Table 1 for a summary of the feedback input divider settings.</p>																
5	PE/HD	I	3-Level	<p>Positive/negative edge control and high/low output drive strength selection. The PE portion of this pin controls which edge of the reference input synchronizes the clock outputs. The HD portion of this pin controls the drive strength of the output clock buffers. The following table summarizes the effects of the PE/HD pin during normal operation.</p> <table border="1"> <thead> <tr> <th><u>PE/HD</u></th> <th><u>Synchronization</u></th> <th><u>Output Drive Strength</u></th> </tr> </thead> <tbody> <tr> <td>LOW</td> <td>Negative Edge</td> <td>Low Drive</td> </tr> <tr> <td>MID</td> <td>Positive Edge</td> <td>High Drive</td> </tr> <tr> <td>HIGH</td> <td>Positive Edge</td> <td>Low Drive</td> </tr> </tbody> </table> <p>Low drive strength outputs provide 12mA of drive strength while the high drive condition results in 24mA of current drive. Output banks operating from a 2.5V power supply guarantee a high drive of 20mA.</p>	<u>PE/HD</u>	<u>Synchronization</u>	<u>Output Drive Strength</u>	LOW	Negative Edge	Low Drive	MID	Positive Edge	High Drive	HIGH	Positive Edge	Low Drive				
<u>PE/HD</u>	<u>Synchronization</u>	<u>Output Drive Strength</u>																		
LOW	Negative Edge	Low Drive																		
MID	Positive Edge	High Drive																		
HIGH	Positive Edge	Low Drive																		

Flatpack Pin No.	Name	I/O	Type	Description												
4	$\overline{\text{PD}}/\text{DIV}$	I	3-Level	<p>Power down and reference divider control. This dual function pin controls the power down operation and selects the input reference divider. Holding the pin low during power up ensures clean RadClock startup that is independent of the behavior of the reference clock. The pin may also be driven low at any time to force a reset to the PLL. The following table summarizes the operating states controlled by the $\overline{\text{PD}}/\text{DIV}$ pin.</p> <table border="1"> <thead> <tr> <th><u>$\overline{\text{PD}}/\text{DIV}$</u></th> <th><u>Operating Mode</u></th> <th><u>Input Reference Divider</u></th> </tr> </thead> <tbody> <tr> <td>LOW</td> <td>Powered Down</td> <td>N/A</td> </tr> <tr> <td>MID</td> <td>Normal Operation</td> <td>$\div 2$</td> </tr> <tr> <td>HIGH</td> <td>Normal Operation</td> <td>$\div 1$</td> </tr> </tbody> </table>	<u>$\overline{\text{PD}}/\text{DIV}$</u>	<u>Operating Mode</u>	<u>Input Reference Divider</u>	LOW	Powered Down	N/A	MID	Normal Operation	$\div 2$	HIGH	Normal Operation	$\div 1$
<u>$\overline{\text{PD}}/\text{DIV}$</u>	<u>Operating Mode</u>	<u>Input Reference Divider</u>														
LOW	Powered Down	N/A														
MID	Normal Operation	$\div 2$														
HIGH	Normal Operation	$\div 1$														
20	LOCK	O	LVTTL	<p>PLL lock indication signal. A HIGH state indicates that the PLL is in a locked condition. A LOW state indicates that the PLL is not locked and the outputs may not be synchronized to the input. As the following table indicates, the level of phase alignment between XTAL1 and FB that will cause the LOCK pin to change states is dependent upon the frequency range selected by the FS input.</p> <table border="1"> <thead> <tr> <th><u>FS</u></th> <th><u>LOCK Resolution</u></th> </tr> </thead> <tbody> <tr> <td>L</td> <td>1.6ns typical</td> </tr> <tr> <td>M</td> <td>1.6ns typical</td> </tr> <tr> <td>H</td> <td>800ps typical</td> </tr> </tbody> </table> <p>** Note: The LOCK pin can only be considered as a valid output when the RadClock is in a normal mode of operation (e.g. $\overline{\text{PD}}/\text{DIV} \neq \text{LOW}$, TEST = LOW, and a valid reference clock is supplied to the XTAL1 input). Until these conditions are met, RadClock is not in a normal operating mode and the LOCK pin may be HIGH or LOW and therefore should not be used in making any logical decisions until the device is in a normal operating mode. Reference the t_{LOCK} parameter in the AC timing specification to determine the delay for the LOCK pin to become valid HIGH following a stable input reference clock and the application of a clock to the FB input.</p>	<u>FS</u>	<u>LOCK Resolution</u>	L	1.6ns typical	M	1.6ns typical	H	800ps typical				
<u>FS</u>	<u>LOCK Resolution</u>															
L	1.6ns typical															
M	1.6ns typical															
H	800ps typical															
43	V_{DDQ4}^2	PWR	Power	<p>Power supply for Bank 4 output buffers. Please see Table 12 for supply level constraints.</p>												
7	V_{DDQ3}^2	PWR	Power	<p>Power supply for Bank 3 output buffers. Please see Table 12 for supply level constraints.</p>												
19, 30	V_{DDQ1}^2	PWR	Power	<p>Power supply for Bank 1 and Bank 2 output buffers. Please see Table 12 for supply level constraints.</p>												
6, 12, 14, 35, 38	V_{DD}^2	PWR	Power	<p>Power supply for internal circuitry. Please see Table 12 for supply level constraints.</p>												
10, 11, 15, 16, 21, 29, 33, 34, 39, 40, 44, 45	V_{SS}	PWR	Power	<p>Ground</p>												

Notes:

- When TEST = MID and $\overline{\text{sOE}} = \text{HIGH}$, the PLL remains active with nF[1:0] = LL functioning as an output disable control for individual output banks. Skew selections remain in effect unless nF[1:0] = LL.
- A bypass capacitor (0.1 μF) should be placed as close as possible to each positive power pin (<0.2"). An additional 1 μF capacitor should be located within 0.2" of the output bank power supplies (V_{DDQ1} , V_{DDQ3} , and V_{DDQ4}). If these bypass capacitors are not close to the pins, their high frequency filtering characteristics will be cancelled by the parasitic inductance of the traces. Additionally, it is recommend that wide traces (0.025" or wider) be used when connecting the decoupling capacitors to their respective power pins on the RadClock.

4.0 ABSOLUTE MAXIMUM RATINGS:¹

(Referenced to V_{SS})

Symbol	Description	Limits	Units
V_{DD}	Core Power Supply Voltage	-0.3 to 4.0	V
V_{DDQ1} , V_{DDQ3} , and V_{DDQ4}	Output Bank Power Supply Voltage	-0.3 to 4.0	V
V_{IN}	Voltage Any Input Pin	-0.3 to $V_{DD} + 0.3$	V
V_{OUT}	Voltage Any Clock Bank Output	-0.3 to $V_{DDQn} + 0.3$	V
V_O	Voltage on XTAL2 and LOCK Outputs	-0.3 to $V_{DD} + 0.3$	V
I_I	DC Input Current	± 10	mA
P_D	Maximum Power Dissipation	1.5	W
T_{STG}	Storage Temperature	-65 to +150	°C
T_J	Maximum Junction Temperature ²	+150	°C
Θ_{JC}	Thermal Resistance, Junction to Case	15	°C/W
ESD_{HBM}	ESD Protection (Human Body Model) - Class II	3000	V

Notes:

1. Stresses outside the listed absolute maximum ratings may cause permanent damage to the device. This is a stress rating only, and functional operation of the device at these or any other conditions beyond limits indicated in the operational sections of this specification is not recommended. Exposure to absolute maximum rating conditions for extended periods may affect device reliability and performance.
2. Maximum junction temperature may be increased to +175°C during burn-in and steady-static life.

5.0 RECOMMENDED OPERATING CONDITIONS:

Symbol	Description	Limits	Units
V_{DD}	Core Operating Voltage	3.0 to 3.6	V
V_{DDQ1} , V_{DDQ3} , and V_{DDQ4}	Output Bank Operating Voltage	2.25 to 3.6	V
V_{IN}	Voltage Any Configuration and Control Input	0 to V_{DD}	V
V_{OUT}	Voltage Any Bank Output	0 to V_{DDQn}	V
T_C	Case Operating Temperature	-55 to +125	°C

6.0 DC INPUT ELECTRICAL CHARACTERISTICS (Pre- and Post-Radiation)*

($V_{DD} = +3.3V \pm 0.3V$; $T_C = -55^\circ C$ to $+125^\circ C$) (For "W" screening, $T_C = -40^\circ C$ to $+125^\circ C$)

Symbol	Description	Conditions	Min.	Max.	Units	
V_{IH}^4	High-level input voltage (XTAL1, FB and \overline{sOE} inputs)		2.0	--	V	
V_{IL}^4	Low-level input voltage (XTAL1, FB and \overline{sOE} inputs)		--	0.8	V	
$V_{IHH}^{1,3}$	High-level input voltage		$V_{DD} - 0.6$	--	V	
$V_{IMM}^{1,3}$	Mid-level input voltage		$V_{DD} \div 2 - 0.3$	$V_{DD} \div 2 + 0.3$	V	
$V_{ILL}^{1,3}$	Low-level input voltage		--	0.6	V	
I_{IL}	Input leakage current (XTAL1, FB and \overline{sOE} inputs)	$V_{IN} = V_{DD}$ or V_{SS} ; $V_{DD} = \text{Max}$	-5	5	μA	
I_{3L}^1	3-Level input DC current	HIGH, $V_{IN} = V_{DD}$	--	200	μA	
		MID, $V_{IN} = V_{DD}/2$	-50	50	μA	
		LOW, $V_{IN} = V_{SS}$	-200	--	μA	
I_{DDPD}	Power-down current	$V_{DD} = V_{DDQn} = +3.0V$; TEST & $\overline{sOE} = \text{HIGH}$; XTAL1, \overline{PD}/DIV , FB, FS, & PE/ HD = LOW; All other inputs are floated; Outputs are not loaded	$T_C = +25^\circ C$	--	100	μA
			$T_C = +125^\circ C$	--	150	μA
			$T_C = -55^\circ C$	--	4.5	mA
C_{IN-2L}^2	Input pin capacitance 2-level inputs	$f = 1\text{MHz}$ @ 0V; $V_{DD} = \text{Max}$	8.5		pF	
C_{IN-3L}^2	Input pin capacitance 3-level inputs	$f = 1\text{MHz}$ @ 0V; $V_{DD} = \text{Max}$	15		pF	

Notes:

* Post-radiation performance guaranteed at $25^\circ C$ per MIL-STD-883 Method 1019, Condition A up to a TID level of $1.0E6$ rad(Si).

- These inputs are normally wired to V_{DD} , V_{SS} , or left unconnected. Internal termination resistors bias unconnected inputs to $V_{DD}/2 \pm 0.3V$. The 3-level inputs include: TEST, \overline{PD}/DIV , PE/HD, FS, nF[1:0], DS[1:0].
- Capacitance is measured for initial qualification and when design changes may affect the input/output capacitance. Capacitance is measured between the designated terminal and V_{SS} at a frequency of 1MHz and a signal amplitude of 50mV rms maximum.
- Pin FS is guaranteed by functional testing.
- For pin FB, this specification is supplied as a design limit, but is neither guaranteed nor tested.

7.0 DC OUTPUT ELECTRICAL CHARACTERISTICS (Pre- and Post-Radiation)*

($V_{DDQn} = +2.5V \pm 10\%$; $V_{DD} = +3.3V \pm 0.3V$; $T_C = -55^\circ C$ to $+125^\circ C$) (For "W" screening, $T_C = -40^\circ C$ to $+125^\circ C$) (Note 1)

Symbol	Description	Conditions	Min.	Max.	Units	
V_{OL}	Output low voltage	$I_{OL} = 12mA$ (PE/HD = LOW or HIGH); (Pins: nQ[1:0])	--	0.4	V	
		$I_{OL} = 20mA$ (PE/HD = MID); (Pins: nQ[1:0])	--	0.4	V	
		$I_{OL} = 2mA$ (Pins: LOCK)	--	0.4	V	
V_{OH}	High-level output voltage	$I_{OH} = -6mA$ (PE/HD=LOWorHIGH); (Pins: nQ[1:0]; $V_{DDQn} = +2.25V$)	2.0	--	V	
		$I_{OH} = -10mA$ (PE/HD=LOWor HIGH); (Pins: nQ[1:0]; $V_{DDQn} = +2.375V$)	2.0	--	V	
		$I_{OH} = -10mA$ (PE/HD = MID); (Pins: nQ[1:0]; $V_{DDQn} = +2.25V$)	2.0	--	V	
		$I_{OH} = -20mA$ (PE/HD = MID); (Pins: nQ[1:0]; $V_{DDQn} = +2.375V$)	2.0	--	V	
		$I_{OH} = -2mA$ (Pins: LOCK)	2.4	--	V	
I_{OSQn}^2	Short-circuit output current	$V_O = V_{DDQn}$ or V_{SS} ; $V_{DDQn} = +2.75V$; PE/HD = MID	-500	500	mA	
		$V_O = V_{DDQn}$ or V_{SS} ; $V_{DDQn} = +2.75V$; PE/HD = LOW or HIGH	-300	300	mA	
$I_{DDOP}^{3,5,6}$	Dynamic supply current	@200MHz (FS = HIGH); $V_{DD} = Max$; $V_{DDQn} = +2.75V$; $C_L = 20pF/output$	UT7R995	--	200	mA
			UT7R995C	--	280	mA
		@50MHz (FS = LOW); $V_{DD} = Max$; $V_{DDQn} = +2.75V$; $C_L = 20pF/output$	UT7R995	--	130	mA
			UT7R995C	--	145	mA
C_{OUT}^4	Output pin capacitance	$f = 1MHz @ 0V$; $V_{DD} = Max$; $V_{DDQn} = +2.75V$	15		pF	

Notes: * Post-radiation performance guaranteed at 25°C per MIL-STD-883 Method 1019, Condition A up to a TID level of 1.0E6 rad(Si).

1. Unless otherwise noted, these tests are performed with V_{DD} and V_{DDQn} at their minimum levels.
2. Supplied as a design limit. Neither guaranteed nor tested.
3. When measuring the dynamic supply current, all outputs are loaded in accordance with the equivalent test load defined in figure 10.
4. Capacitance is measured for initial qualification and when design changes may affect the input/output capacitance. Capacitance is measured between the designated terminal and V_{SS} at a frequency of 1MHz and a signal amplitude of 50mV rms maximum.
5. For the UT7R995, the 200MHz test condition is based on an XTAL1 frequency of 200MHz. For the UT7R995C, the 200MHz test condition is based on an XTAL1 frequency of 16.666667MHz, and a N-divider setting of 12.
6. To reduce power consumption for the device, the user may tie the unused V_{DDQn} pins to V_{SS} .

7.0 DC OUTPUT ELECTRICAL CHARACTERISTICS (Pre- and Post-Radiation)*

($V_{DDQn} = +3.3V \pm 0.3V$; $V_{DD} = +3.3V \pm 0.3V$; $T_C = -55^\circ C$ to $+125^\circ C$) (For "W" screening, $T_C = -40^\circ C$ to $+125^\circ C$) (Note 1)

Symbol	Description	Conditions	Min.	Max.	Units	
V_{OL}	Output low voltage	$I_{OL} = 12mA$ (PE/HD = LOW or HIGH); (Pins: nQ[1:0])	--	0.4	V	
		$I_{OL} = 24mA$ (PE/HD = MID); (Pins: nQ[1:0])	--	0.4	V	
		$I_{OL} = 2mA$ (Pins: LOCK)	--	0.4	V	
V_{OH}	High-level output voltage	$I_{OH} = -12mA$ (PE/HD = LOW or HIGH); (Pins: nQ[1:0])	2.4	--	V	
		$I_{OH} = -24mA$ (PE/HD = MID); (Pins: nQ[1:0])	2.4	--	V	
		$I_{OH} = -2mA$ (Pins: LOCK)	2.4	--	V	
I_{OSQn}^2	Short-circuit output current	$V_O = V_{DDQn}$ or V_{SS} ; $V_{DDQn} = +3.6V$; PE/HD = MID	-600	600	mA	
		$V_O = V_{DDQn}$ or V_{SS} ; $V_{DDQn} = +3.6V$; PE/HD = LOW or HIGH	-300	300	mA	
$I_{DDOP}^{3,5,6}$	Dynamic supply current	@200MHz (FS = HIGH); $V_{DD} = \text{Max}$; $V_{DDQn} = +3.6V$; $C_L = 20pF/\text{output}$	UT7R995	--	250	mA
			UT7R995C	--	360	mA
		@50MHz (FS = LOW); $V_{DD} = \text{Max}$; $V_{DDQn} = +3.6V$; $C_L = 20pF/\text{output}$	UT7R995	--	150	mA
			UT7R995C	--	160	mA
C_{OUT}^4	Output pin capacitance	$f = 1MHz @ 0V$; $V_{DD} = \text{Max}$; $V_{DDQn} = +3.6V$	15		pF	

Notes: * Post-radiation performance guaranteed at $25^\circ C$ per MIL-STD-883 Method 1019, Condition A up to a TID level of $1.0E6$ rad(Si).

1. Unless otherwise noted, these tests are performed with V_{DD} and V_{DDQn} at their minimum levels.
2. Supplied as a design limit. Neither guaranteed nor tested.
3. When measuring the dynamic supply current, all outputs are loaded in accordance with the equivalent test load defined in figure 10.
4. Capacitance is measured for initial qualification and when design changes may affect the input/output capacitance. Capacitance is measured between the designated terminal and V_{SS} at a frequency of 1MHz and a signal amplitude of 50mV rms maximum.
5. For the UT7R995, the 200MHz test condition is based on an XTAL1 frequency of 200MHz. For the UT7R995C, the 200MHz test condition is based on an XTAL1 frequency of 16.666667MHz, and a N-divider setting of 12.
6. To reduce power consumption for the device, the user may tie the unused V_{DDQn} pins to V_{SS} .

8.0 AC INPUT ELECTRICAL CHARACTERISTICS (Pre- and Post-Radiation)*

($V_{DD} = V_{DDQn} = +3.3V \pm 0.3V$; $T_C = -55^{\circ}C$ to $+125^{\circ}C$) (Note 1)

Symbol	Description	Condition	Min.	Max.	Unit
t_R, t_F ^{2, 3}	Input rise/fall time	$V_{IH}(\text{min}) - V_{IL}(\text{max})$	--	20	ns/V
t_{PWC} ⁶	Input clock pulse	HIGH or LOW	2	--	ns
t_{XTAL} ⁷	Input clock period	$1 \div F_{XTAL}$	5	500	ns
t_{DCIN} ⁶	Input clock duty cycle	HIGH or LOW	10	90	%
f_{XTAL} ^{4, 5, 7} Digital reference input frequency		FS = LOW; $\overline{PD}/DIV = \text{HIGH}$	2	50	MHz
		FS = LOW; $\overline{PD}/DIV = \text{MID}$	4	100	MHz
		FS = MID; $\overline{PD}/DIV = \text{HIGH}$	4	100	MHz
		FS = MID; $\overline{PD}/DIV = \text{MID}$	8	200	MHz
		FS = HIGH; $\overline{PD}/DIV = \text{HIGH}$	8	200	MHz
		FS = HIGH; $\overline{PD}/DIV = \text{MID}$	16	200	MHz

Notes:

* Post-radiation performance guaranteed at $25^{\circ}C$ per MIL-STD-883 Method 1019.

- Reference Figure 11 for clock output loading circuit that is equivalent to the load circuit used for all AC testing. The input waveform used to test these parameters is shown in Figure 9.
- Supplied only as a design guideline, neither tested nor guaranteed.
- When driving the UT7R995C with a crystal, the XTAL1 pin does not define maximum input rise/fall time.
- Although the input reference frequencies are defined as-low-as 2MHz, the N and R dividers must be selected to ensure the PLL operates from 24MHz-50MHz when FS = LOW, 48MHz-100MHz when FS = MID, and 96MHz-200MHz when FS = HIGH.
- The UT7R995C is guaranteed by characterization for quartz crystal frequencies ranging from 2MHz to 48MHz. Contact the factory for support using quartz crystals that oscillate above 48MHz.
- For the UT7R995C only, this parameter is guaranteed by characterization, but not tested.
- For the UT7R995C only, this parameter is guaranteed by characterization, but only tested for frequencies <100 MHz.

9.0 AC OUTPUT ELECTRICAL CHARACTERISTICS (Pre- and Post-Radiation)*

($V_{DD} = +3.3V \pm 0.3V$; $T_C = -55^\circ C$ to $+125^\circ C$) (For "W" screening, $T_C = -40^\circ C$ to $+125^\circ C$) (Note 1)

Symbol	Description	Condition	Min.	Max.	Unit	
f_{OR}	Output frequency range	$V_{DD}Q_n = +3.3V$	6	200	MHz	
VCO_{LR}	VCO lock range	$V_{DD}Q_n = +3.3V$	24	200	MHz	
VCO_{LBW}^2	VCO loop bandwidth	$V_{DD} = V_{DD}Q_n = +3.3V$; $T_C = \text{Room Temperature}$	0.25	3.5	MHz	
$t_{SKEWPR}^{3,8}$	Matched-pair skew	Skew between the earliest and the latest output transitions within the same bank.	--	100	ps	
$t_{SKEW0}^{3,8}$	Output-output skew	Skew between the earliest and the latest output transitions among all outputs at $0t_{J_1}$.	--	200	ps	
$t_{SKEW1}^{3,8}$		Skew between the earliest and the latest output transitions among all outputs for which the same phase delay has been selected.	--	200	ps	
t_{SKEW2}^3		Skew between the nominal output rising edge to the inverted output falling edge	--	500	ps	
t_{SKEW3}^3		Skew between non-inverted outputs running at different frequencies.	--	500	ps	
t_{SKEW4}^3		Skew between nominal to inverted outputs running at different frequencies.	--	600	ps	
t_{SKEW5}^3		Skew between nominal outputs at different power supply levels.	--	650	ps	
t_{PART}^8	Part-part skew	Skew between the outputs of any two devices under identical settings and conditions ($V_{DD}Q_n$, V_{DD} , temp, air flow, frequency, etc).	--	450	ps	
$t_{PDO}^{4,8}$	XTAL1 to FB propagation delay	$V_{DD} = V_{DD}Q_n = +3.3V$; $T_C = \text{Room Temperature}$	-250	+250	ps	
t_{ODCV}^8	Output duty cycle	$f_{out} < 100 \text{ MHz}$, measured at $V_{DD} \div 2$	48	52	%	
		$f_{out} > 100 \text{ MHz}$, measured at $V_{DD} \div 2$	45	55	%	
t_{PWH}	Output high time deviation from 50%	Measured at 2.0V; $V_{DD}Q_n = +3.3V$	--	1.5	ns	
t_{PWL}	Output low time deviation from 50%	Measured at 0.8V; $V_{DD}Q_n = +3.3V$	--	2.0	ns	
t_{ORISE}^8 & t_{OFALL}	Output rise/fall time	Measured as transition time between $V_{OH} = +1.7V$ and $V_{OL} = +0.7V$ for $V_{DD} = 3.0V$; $V_{DD}Q_n = +2.25V$; $C_L = 40pF$	PE/HD = HIGH	0.30	1.5	ns
			PE/HD = MID	0.25	1.25	ns
		Measured as transition time between $V_{OH} = +2.0V$ and $V_{OL} = +0.8V$ for $V_{DD} = 3.6V$; $V_{DD}Q_n = +3.3V$; $C_L = 40pF$	PE/HD = HIGH	0.20	1.25	ns
			PE/HD = MID	0.10	1.0	ns
t_{LOCK}^5	PLL lock time		--	0.5	ms	
$t_{LOCKRES}^{2,6}$	LOCK Pin Resolution	FS = LOW	1.6ns \pm 200ps typ.		ns	
		FS = MID	1.6ns \pm 200ps typ.		ns	
		FS = HIGH	800ps \pm 100ps typ.		ps	

Symbol	Description	Condition	Min.	Max.	Unit
t_{CCJ} ⁷	Cycle-cycle jitter	Divide by 1 output frequency, FB = divide by 12	--	50	ps

Notes:

1. Reference Figure 11 for clock output loading circuit that is equivalent to the load circuit used for all AC testing.
2. Supplied as a design guideline. Neither guaranteed nor tested.
3. Test load = 40pF, terminated to $V_{DD} \div 2$. All outputs are equally loaded. See figure 11.
4. t_{PD} is measured at 1.5V for $V_{DD} = 3.3V$ with XTAL1 rise/fall times of 1ns between 0.8V-2.0V.
5. t_{LOCK} is the time that is required before outputs synchronize to XTAL1 as determined by the phase alignment between the XTAL1 and FB inputs. This specification is valid with stable power supplies which are within normal operating limits.
6. Lock detector circuit will monitor the phase alignment between the XTAL1 and FB inputs. When the phase separation between these two inputs is greater than the amount listed, then the LOCK pin will drop low signaling that the PLL is out of lock.
7. This parameter is guaranteed by measuring cycle-cycle jitter on 55,000, back-to-back clock cycles.
8. Guaranteed by characterization, but not tested.

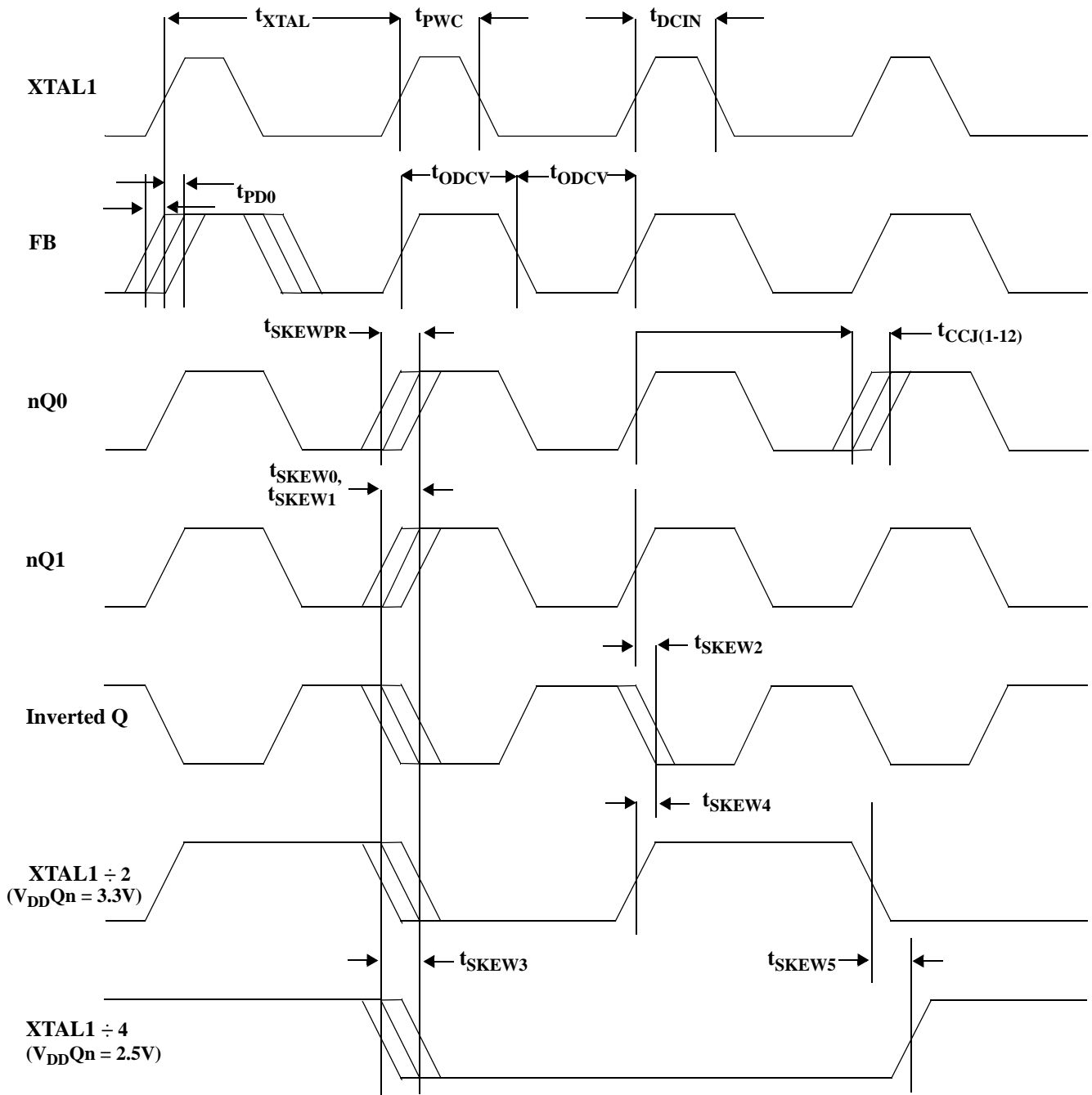

Figure 6. AC Timing Diagram

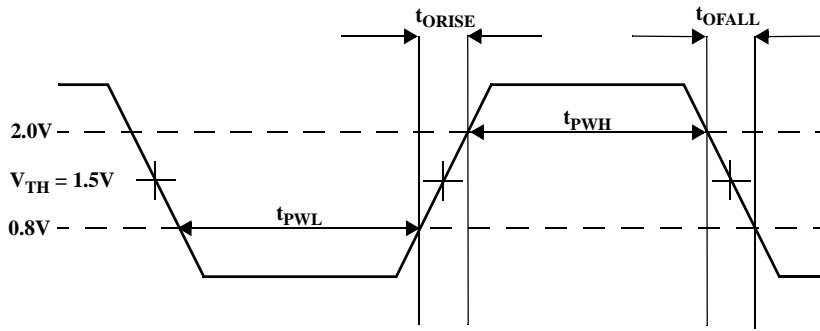

Figure 7. +3.3V LVTTTL Output Waveform

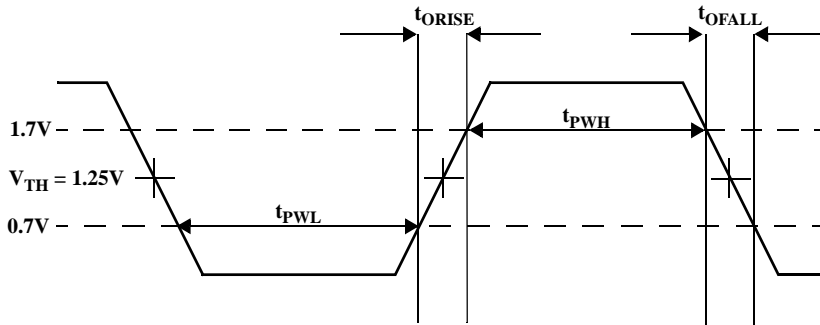

Figure 8. +2.5V LVTTTL Output Waveform

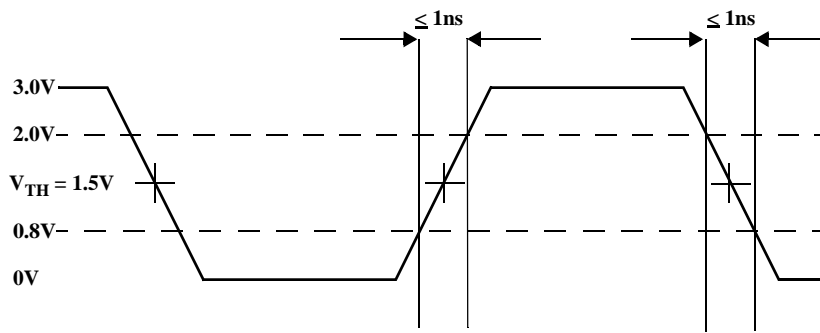

Figure 9. +3.3V LVTTTL Input Test Waveform



Figure 10.
Output Test Load Circuit for LOCK and
Dynamic Power Supply Current Measurements

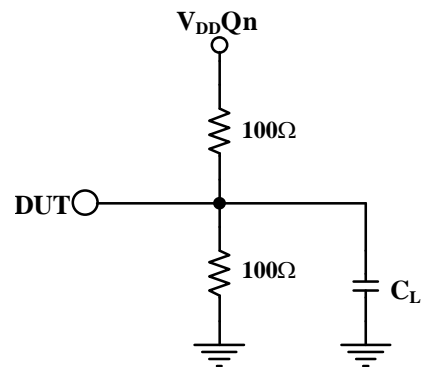
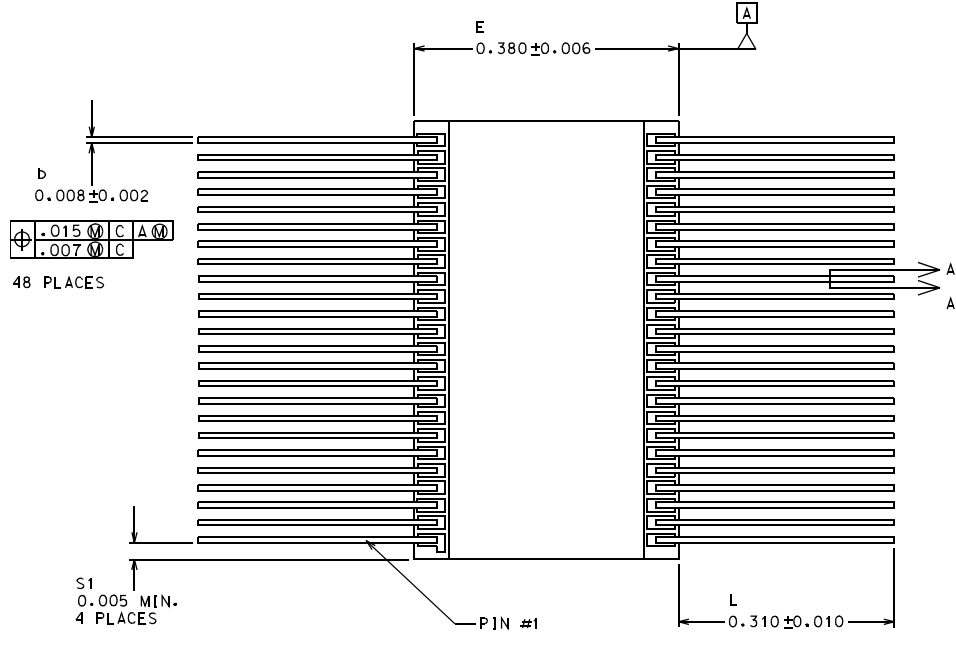
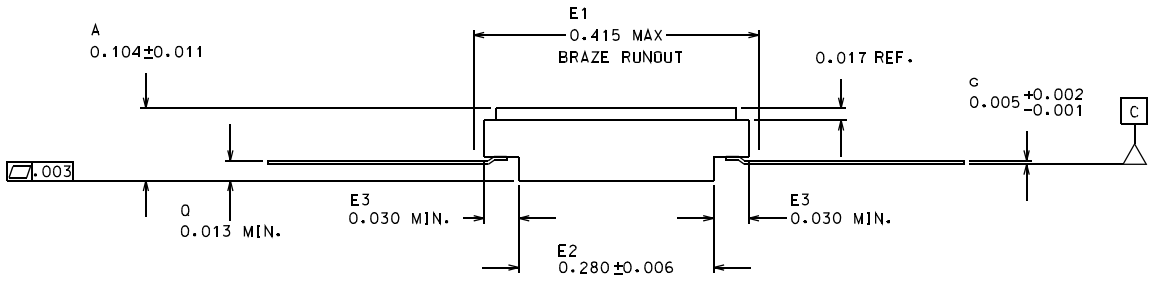
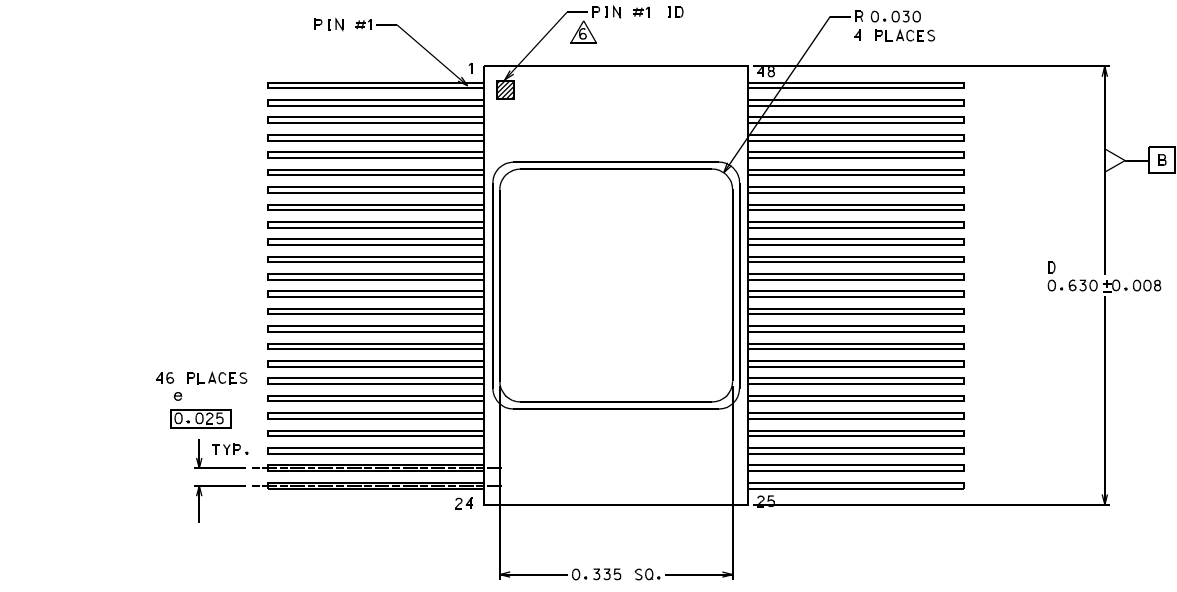

Figure 11.
Clock Output AC Test Load Circuit

Note: This is not the recommended termination
for normal user operation.



- Notes:**
1. All exposed metallized areas are gold plated over electrically plated nickel per MIL-PRF-38535.
 2. The lid is electrically connected to V_{SS} .
 3. Lead finishes are in accordance with MIL-PRF-38535.
 4. Dimension symbology is in accordance with MIL-PRF-38535.
 5. Lead position and coplanarity are not measured.
 6. ID mark symbol is vendor option: no alphanumerics.

Figure 12. 48-lead Ceramic

ORDERING INFORMATION

UT7R995 and UT7R995C:

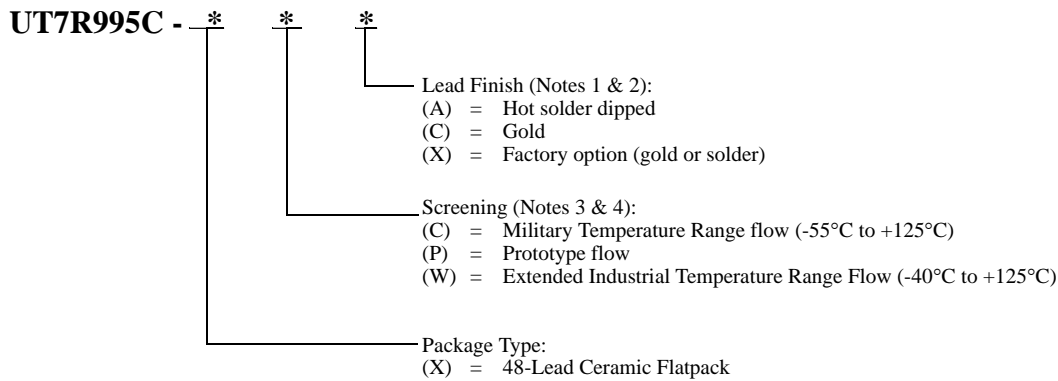
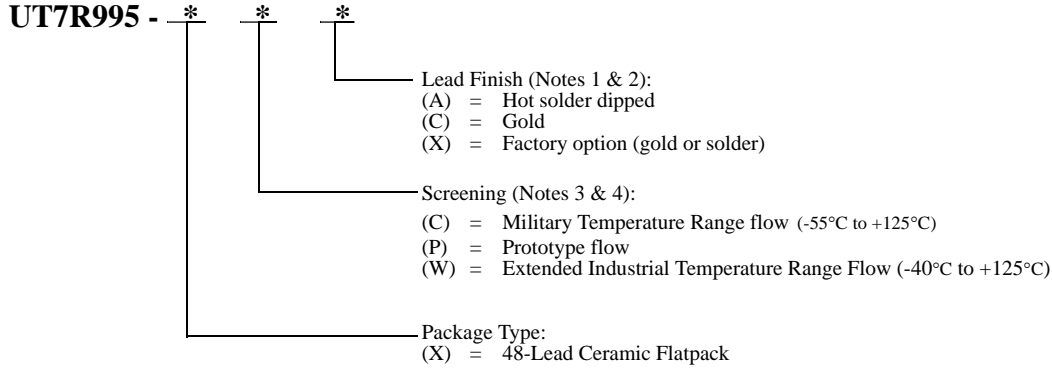

Notes:

1. Lead finish (A,C, or X) must be specified.
2. If an "X" is specified when ordering, then the part marking will match the lead finish and will be either "A" (solder) or "C" (gold).
3. Prototype flow per UTMC Manufacturing Flows Document. Tested at 25°C only. Lead finish is GOLD ONLY. Radiation neither tested nor guaranteed.
4. Military Temperature Range flow per Aeroflex Colorado Springs Manufacturing Flows Document. Devices are tested at -55°C, room temp, and 125°C. Radiation neither tested nor guaranteed.

UT7R995 and UT7R995C: SMD

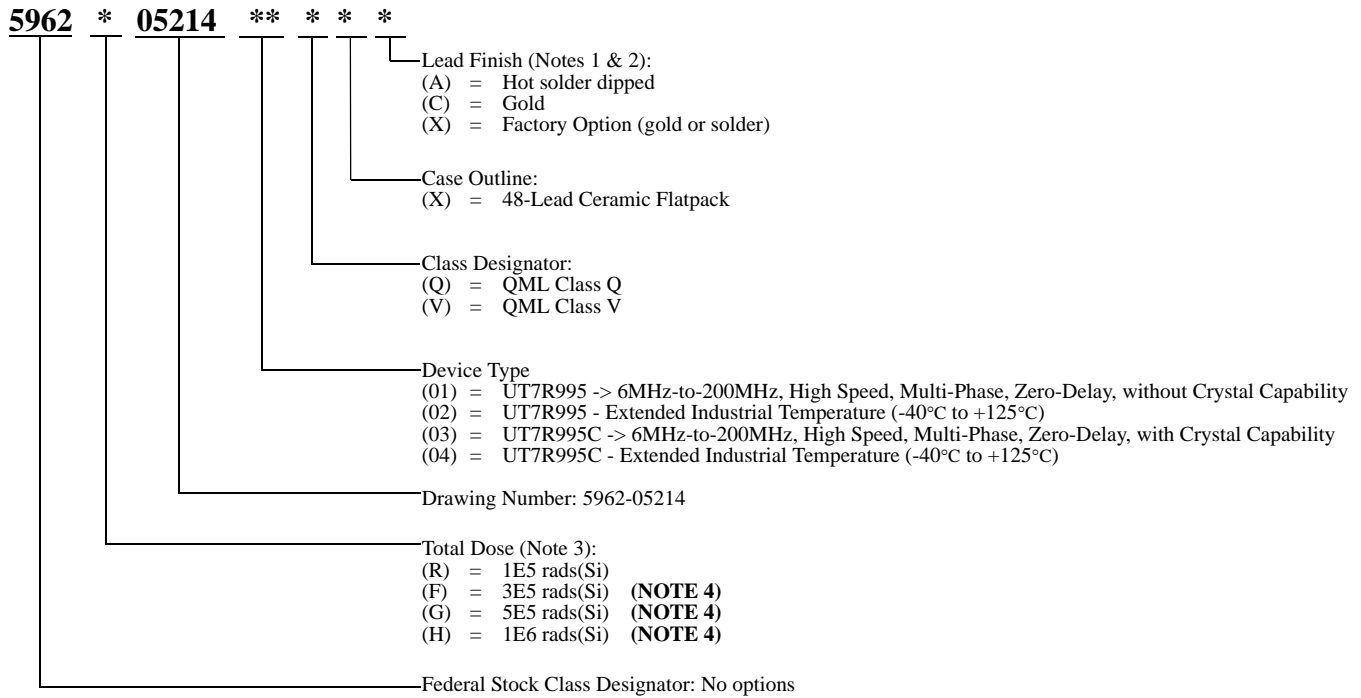

Notes:

1. Lead finish (A,C, or X) must be specified.
2. If an "X" is specified when ordering, part marking will match the lead finish and will be either "A" (solder) or "C" (gold).
3. Total dose radiation must be specified when ordering. QML Q and QML V are not available without radiation hardening.
4. These radiation screen levels are currently unavailable. Contact the factory for information regarding lead-time and availability.

Aeroflex Colorado Springs - Datasheet Definition

Advanced Datasheet - Product In Development

Preliminary Datasheet - Shipping Prototype

Datasheet - Shipping QML & Reduced Hi-Rel

COLORADO

Toll Free: 800-645-8862
Fax: 719-594-8468

INTERNATIONAL

Tel: 805-778-9229
Fax: 805-778-1980

NORTHEAST

Tel: 603-888-3975
Fax: 603-888-4585

SE AND MID-ATLANTIC

Tel: 321-951-4164
Fax: 321-951-4254

WEST COAST

Tel: 949-362-2260
Fax: 949-362-2266

CENTRAL

Tel: 719-594-8017
Fax: 719-594-8468

www.aeroflex.com info-ams@aeroflex.com

Aeroflex Colorado Springs, Inc., reserves the right to make changes to any products and services herein at any time without notice. Consult Aeroflex or an authorized sales representative to verify that the information in this data sheet is current before using this product. Aeroflex does not assume any responsibility or liability arising out of the application or use of any product or service described herein, except as expressly agreed to in writing by Aeroflex; nor does the purchase, lease, or use of a product or service from Aeroflex convey a license under any patent rights, copyrights, trademark rights, or any other of the intellectual rights of Aeroflex or of third parties.



Our passion for performance is defined by three attributes represented by these three icons: solution-minded, performance-driven and customer-focused