

AsahiKASEI

ASAHI KASEI EMD

AK4345**100dB 96kHz 24-Bit Stereo 3.3V $\Delta\Sigma$ DAC with DIT****GENERAL DESCRIPTION**

The AK4345 is a 24bit low voltage and low power stereo DAC with an integrated Digital Audio Interface Transmitter. The AK4345 uses an Advanced Multi-Bit $\Delta\Sigma$ architecture, which achieves 100dB dynamic range at 3.3V operation. The AK4345 integrates both switched-capacitor and continuous time filters, enabling performance for systems that have excessive clock jitter. The output voltage level can be set as high as 1Vrms. The AK4345 is offered in a space saving 16pin TSSOP package.

FEATURES

- Sampling Rate: 8kHz ~ 96kHz
- 24-Bit 8 times FIR Digital Filter
- SCF with high tolerance to clock jitter
- Single-ended output buffer
- Digital de-emphasis for 32kHz, 44.1kHz, 48kHz sampling
- I/F Format: 24-Bit MSB justified, 16/24-Bit LSB justified, I²S Compatible
- Master Clock:
 - 512/768/1024/1536fs for Half Speed (8kHz ~ 24kHz)
 - 256/384/512/768fs for Normal Speed (8kHz ~ 48kHz)
 - 128/192/256/384fs for Double Speed (48kHz ~ 96kHz)
- μ P Interface: 4-wire/3-wire
- DIT Bypass mode
- CMOS Input Level
- THD+N: -90dB
- DR, S/N: 100dB
- DAC output voltage level: 1Vrms (@VDD=3.3V)
- DIT
 - AES3, IEC60958, S/PDIF, EIAJ CP1201 Compatible
 - 1-channel Transmission output
 - 42-bit Channel Status Buffer
- Power Supply: 2.7 to 3.6V
- Ta = -20 ~ 85°C
- 16pin TSSOP

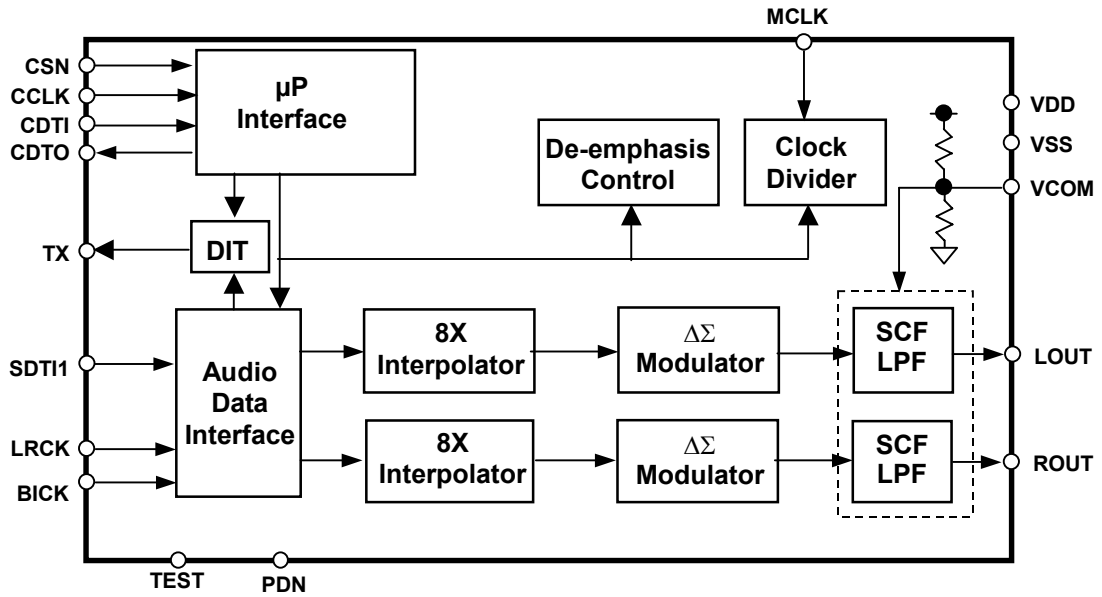


Figure 1. AK4345 Block Diagram (Mode="0")

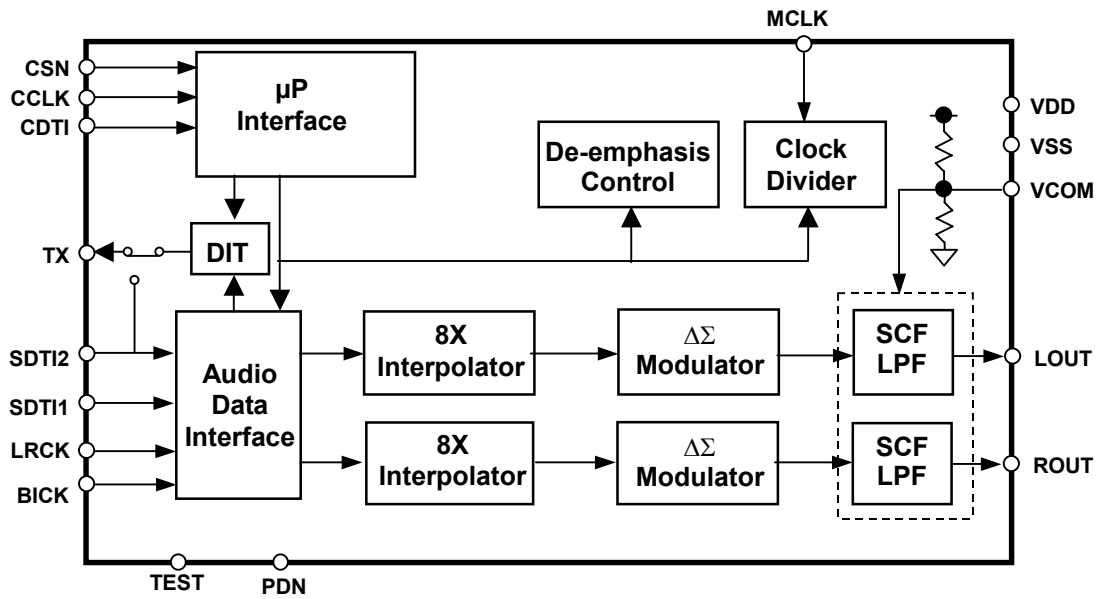


Figure 2. AK4345 Block Diagram (Mode="1")

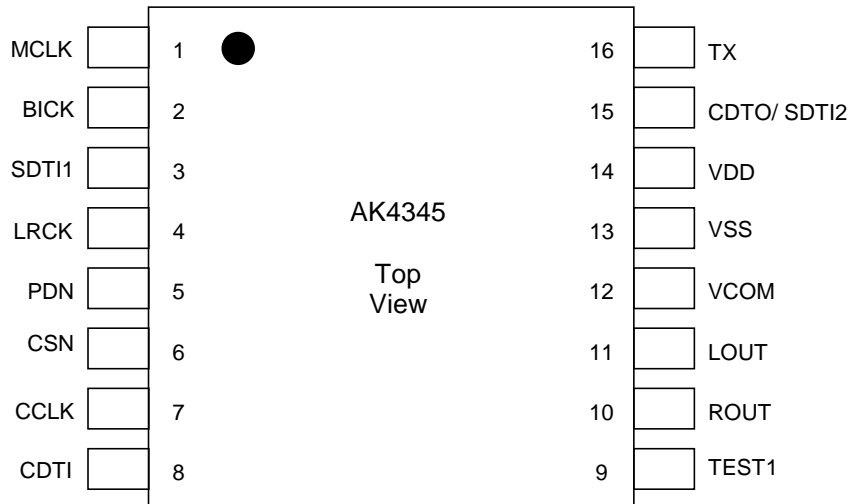
■ Ordering Guide

AK4345ET
AKD4345

-20 ~ +85°C
Evaluation Board for AK4345

16pin TSSOP (0.65mm pitch)

■ Pin Layout



PIN/FUNCTION

No.	Pin Name	I/O	Function
1	MCLK	I	Master Clock Input Pin
2	BICK	I	Audio Serial Data Clock Pin
3	SDTI1	I	Audio Serial Data Input Pin1
4	LRCK	I	Input Channel Clock Pin
5	PDN	I	Full Power Down Mode Pin “L” : Power down, “H” : Power up
6	CSN	I	Chip Select Pin
7	CCLK	I	Control Data Clock Pin
8	CDTI	I	Control Data Input Pin
9	TEST1	I	TEST Pin This pin must be OPEN.
10	ROUT	O	Rch Analog Output Pin, The output is “Hi-Z” when PDN pin = “L”.
11	LOUT	O	Lch Analog Output Pin, The output is “Hi-Z” when PDN pin = “L”.
12	VCOM	O	Common Voltage Output Pin, $0.5 \times VDD$ Normally connected to VSS with a $4.7\mu\text{F}$ (min. $1\mu\text{F}$, max. $10\mu\text{F}$) electrolytic Capacitor. The output is “L” when PDN pin = “L”.
13	VSS	-	Ground Pin
14	VDD	-	Power Supply Pin, 2.7 ~ 3.6V
15	CDTO	O	Control Data Output Pin, The output is “Hi-Z” when PDN pin = “L”.
	SDTI2	I	Audio Serial Data Input Pin2
16	TX	O	Transmit Channel Output Pin, The output is “L” when PDN pin = “L”.

Note: All digital input pins should not be left floating.

ABSOLUTE MAXIMUM RATINGS

(VSS=0V; Note 1)

Parameter	Symbol	min	max	Units
Power Supply	VDD	-0.3	4.6	V
Input Current, Any Pin Except Supplies	IIN	-	±10	mA
Digital Input Voltage (Note 2)	VIND	-0.3	VDD+0.3	V
Ambient Temperature (Powered applied)	Ta	-20	85	°C
Storage Temperature	Tstg	-65	150	°C

Note 1. All voltages with respect to ground.

Note 2. MCLK, BICK, SDTI1, LRCK, PDN, CSN, CCLK, CDTI, SDTI2

WARNING: Operation at or beyond these limits may result in permanent damage to the device.

Normal operation is not guaranteed at these extremes.

RECOMMENDED OPERATING CONDITIONS

(VSS=0V; Note 1)

Parameter	Symbol	min	typ	max	Units
Power Supply	VDD	2.7	3.3	3.6	V

Note 1. All voltages with respect to ground.

WARNING: AKEMD assumes no responsibility for the usage beyond the conditions in this datasheet.

ANALOG CHARACTERISTICS

(Ta=25°C; VDD=3.3V; VSS=0V; fs=44.1kHz, 96kHz; BICK=64fs; Signal Frequency=1kHz; 24bit Data; Measurement frequency=20Hz ~ 20kHz at fs=44.1kHz, 20Hz ~ 40kHz at fs=96kHz; unless otherwise specified)

Parameter		min	typ	max	Units
Dynamic Characteristics (GAIN bit= "1") :					
Resolution				24	Bits
THD+N	fs=44.1kHz	0dBFS	-90	-80	dB
	BW=20kHz	-60dBFS	-37	-	dB
	fs=96kHz	0dBFS	-88	-	dB
	BW=40kHz	-60dBFS	-34	-	dB
DR	(-60dBFS with A-weighted)		92	100	dB
S/N	(A-weighted)		92	100	dB
Interchannel Isolation		80	100		dB
DC Accuracy:					
Interchannel Gain Mismatch			0.2	0.5	dB
Gain Drift			100	-	ppm/°C
Output Voltage: GAIN bit= "1"	(Note 3)	2.60	2.8	3.0	Vpp
Output Voltage: GAIN bit= "0"	(Note 4)	2.05	2.2	2.35	Vpp
Load Resistance	(Note 5)	10			kΩ
Load Capacitance				25	pF
Power Supplies					
Power Supply Current					
Normal Operation (PDN pin = "H", fs=44.1kHz)	(Note 6)		7.0		mA
Normal Operation (PDN pin = "H", fs=96kHz)	(Note 6)		8.5	12.8	mA
Full Power-down mode (PDN pin = "L")	(Note 7)		10	50	μA

Note 3. Full-scale voltage (0dB). Output voltage scales with the voltage of VDD, $V_{out} = 0.85 \times VDD$ (typ).

Note 4. Full-scale voltage (0dB). Output voltage scales with the voltage of VDD, $V_{out} = 0.67 \times VDD$ (typ).

Note 5. For AC-load.

Note 6. RSTN bit= "1", PW bit= "1", TX pin: open. When TX pin = 20pF, power supply current (IDD@3.3V) is 9.0mA(typ)@fs= 96kHz.

Note 7. All digital input pins are fixed to VDD or VSS.

FILTER CHARACTERISTICS

(Ta=25°C; VDD=2.7 ~ 3.6V; fs=44.1kHz; DEM1 bit= "0", DEM0 bit= "1")

Parameter	Symbol	min	typ	max	Units
DAC Digital Filter:					
Passband (Note 8)	±0.05dB -6.0dB	PB	0	22.05	20.0
			-		-
Stopband (Note 8)		SB	24.1		kHz
Passband Ripple		PR		±0.01	dB
Stopband Attenuation		SA	54		dB
Group Delay (Note 9)		GD	-	24.0	1/fs
Digital Filter + SCF + CTF:					
Frequency Response	0 ~ 20kHz	FR	-	±0.1	dB
	~ 40kHz (Note 10)		-	±0.2	-

Note 8. The passband and stopband frequencies scale with fs (system sampling rate).

Note 9. The calculating delay time which occurred by digital filtering. This time is from setting the 16/24bit data of both channels to input register to the output of analog signal.

Note 10. At fs=96kHz.

DC CHARACTERISTICS

(Ta=25°C; VDD=2.7 ~ 3.6V)

Parameter	Symbol	min	typ	max	Units
High-Level Input Voltage	VIH	70%VDD	-	-	V
Low-Level Input Voltage	VIL	-	-	30%VDD	V
High-Level Output Voltage (Iout=-80μA)	VOH1	VDD-0.4	-	-	V
Low-Level Output Voltage (Iout=80μA)	VOL1	-	-	0.4	V
Input Leakage Current	Iin	-	-	± 10	μA

TX CHARACTERISTICS

(Ta=25°C; VDD=2.7 ~ 3.6V)

Parameter	Symbol	min	typ	max	Units
High-Level Output Voltage (Iout=-400μA)	VOH2	VDD-0.4	-	-	V
Low-Level Output Voltage (Iout=400μA)	VOL2	-	-	0.4	V
Load Capacitance	CL	-	-	50	pF

SWITCHING CHARACTERISTICS

(Ta=25°C; VDD=2.7 ~ 3.6V; CL = 20pF)

Parameter	Symbol	min	typ	max	Units
Master Clock Frequency					
Half Speed Mode (512/768/1024/1536fs)	fCLK	4.096		36.864	MHz
Normal Speed Mode (256/384/512/768fs)	fCLK	2.048		36.864	MHz
Double Speed Mode (128/192/256/384fs)	fCLK	6.144		36.864	MHz
Duty Cycle	dCLK	40		60	%
LRCK Frequency					
Half Speed Mode (DFS1-0 = "10")	fsh	8		24	kHz
Normal Speed Mode (DFS1-0 = "00")	fsn	8		48	kHz
Double Speed Mode (DFS1-0 = "01")	fsd	48		96	kHz
Duty Cycle	dCLK	45		55	%
Audio Interface Timing					
BICK Period					
Half Speed Mode	tBCK	1/128fs			ns
Normal Speed Mode	tBCK	1/128fs			ns
Double Speed Mode	tBCK	1/64fs			ns
BICK Pulse Width Low					
	tBCKL	70			ns
Pulse Width High					
	tBCKH	70			ns
BICK "↑" to LRCK Edge (Note 11)	tBLR	40			ns
LRCK Edge to BICK "↑" (Note 11)	tLRB	40			ns
SDTI Hold Time	tSDH	40			ns
SDTI Setup Time	tSDS	40			ns
Control Interface Timing					
CCLK Period	tCCK	200			ns
CCLK Pulse Width Low					
	tCCKL	80			ns
Pulse Width High					
	tCCKH	80			ns
CDTI Setup Time	tCDS	40			ns
CDTI Hold Time	tCDH	40			ns
CSN "H" Time	tCSW	150			ns
CSN "↓" to CCLK "↑"	tCSS	150			ns
CCLK "↑" to CSN "↑"	tCSH	50			ns
CDTO Delay	tDCD			45	ns
CSN "↑" to CDTO Hi-Z	tCCZ			70	ns
Power-Down & Reset Timing					
PDN Pulse Width (Note 12)	tPD	4			ms/μF

Note 11. BICK rising edge must not occur at the same time as LRCK edge.

Note 12. The AK4345 can be reset by bringing PDN pin = "L".

The PDN pulse width is proportional to the value of the capacitor (C) connected to VCOM pin. $t_{PD} = 4000 \times C$.

When $C = 4.7\mu\text{F}$, t_{PD} is 19ms(min).

The value of the capacitor (C) connected with VCOM pin should be $1\mu\text{F} \leq C \leq 10\mu\text{F}$.

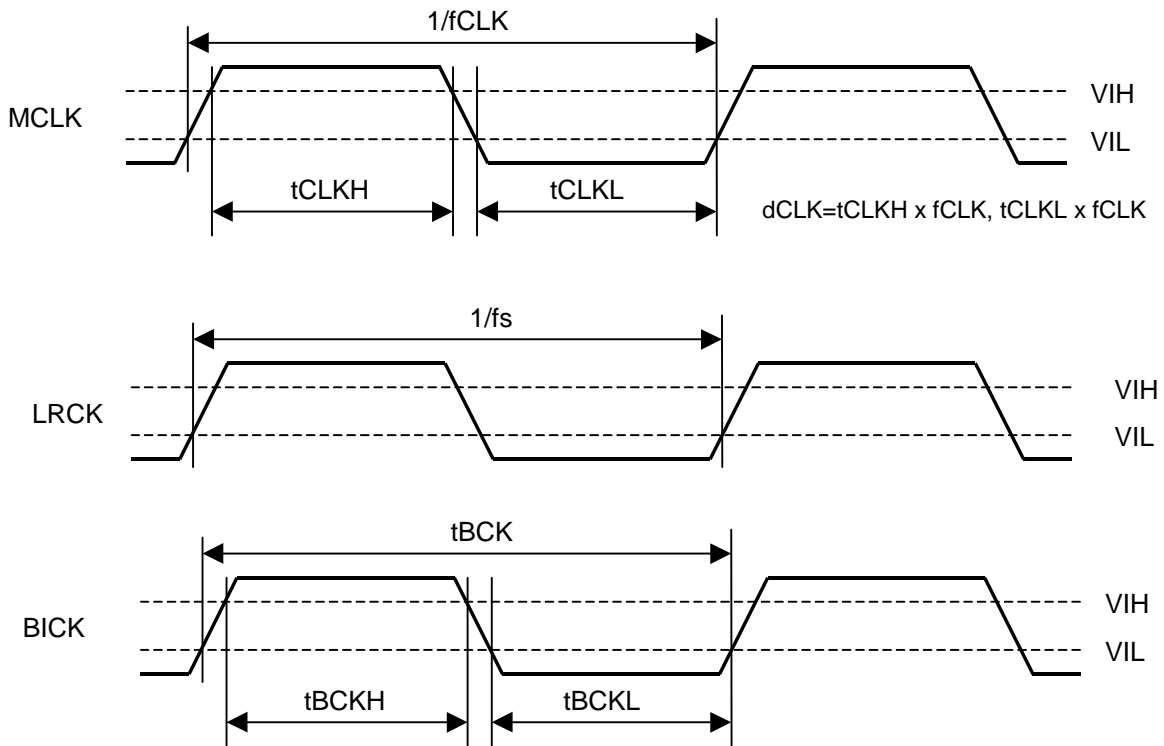
■ Timing Diagram


Figure 3. Clock Timing

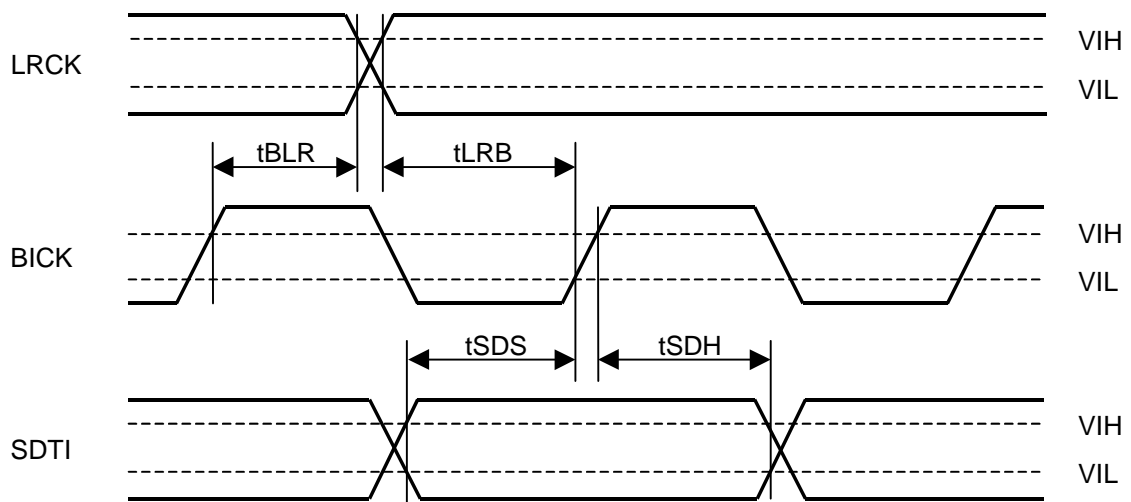


Figure 4. Serial Interface Timing

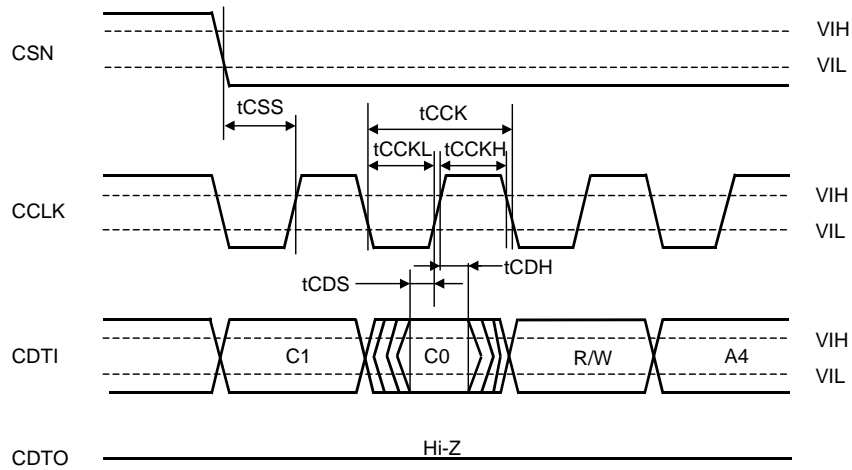


Figure 5. WRITE/READ Command Input Timing in 3-wire/4-wire serial mode

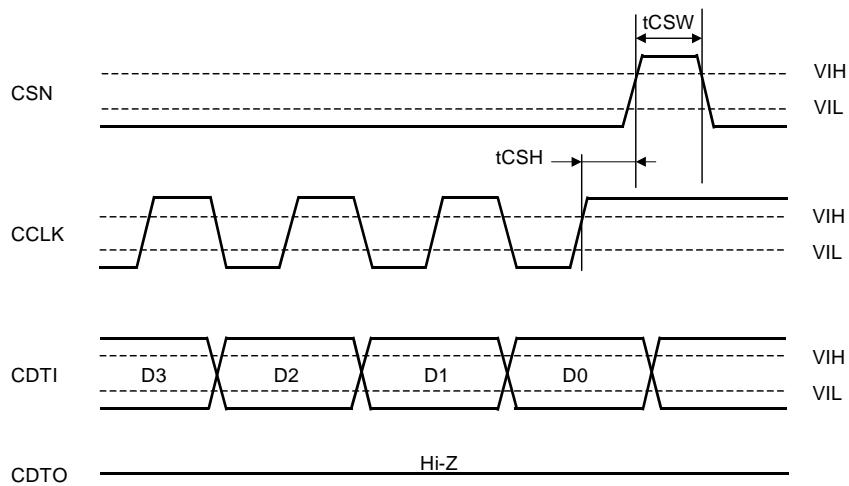


Figure 6. WRITE Data Input Timing in 3-wire/4-wire serial mode

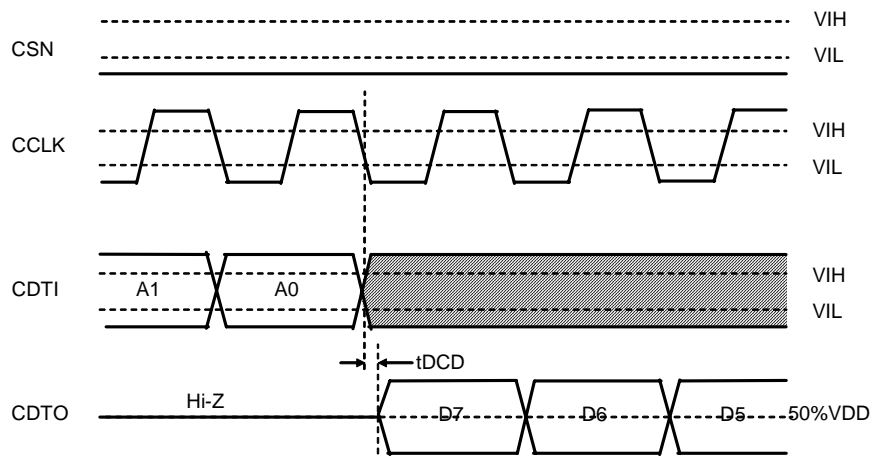


Figure 7. READ Data Output Timing 1 in 4-wire serial mode

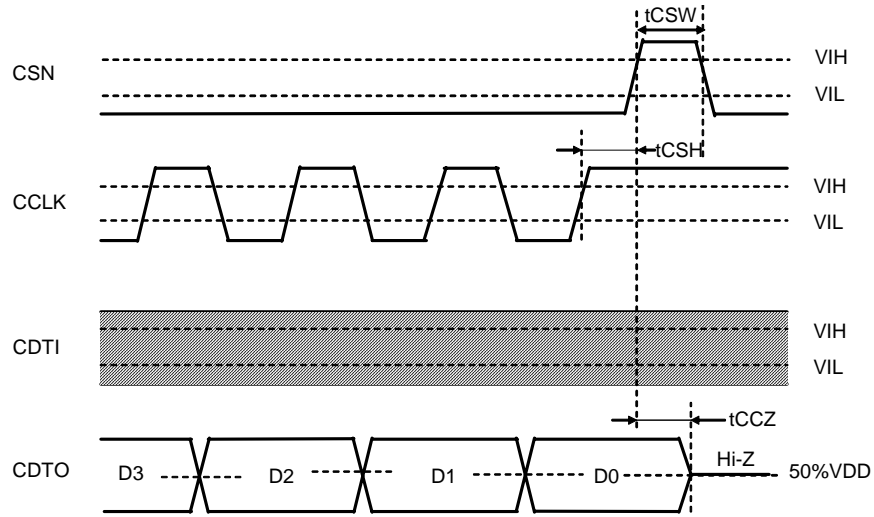


Figure 8. READ Data Output Timing 2 in 4-wire serial mode

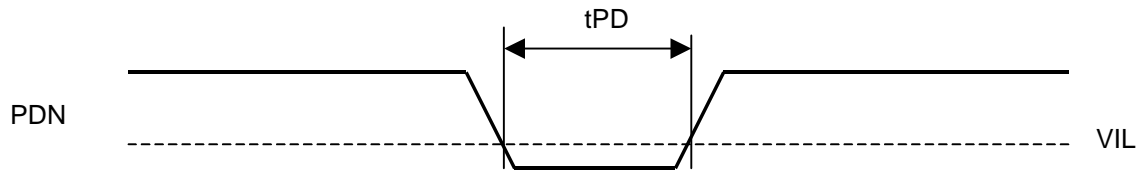


Figure 9. Power-Down & Reset Timing

OPERATION OVERVIEW

■ System Clock

The external clocks, which are required to operate the AK4345, are MCLK, BICK and LRCK. The master clock (MCLK) should be synchronized with LRCK but the phase is not critical. The MCLK is used to operate the digital interpolation filter and the delta-sigma modulator. The MCLK frequency is detected from the relation between MCLK and LRCK automatically. The Half speed, the Normal speed and the Double speed mode are selected with the DFS1-0 bits (Table 1). The sampling speed mode is set depending on the MCLK frequency automatically for Auto mode (DFS1 bit = DFS0 bit = "1") (Table 2).

The AK4345 is automatically placed in the reset mode when MCLK stops in the normal operation mode (PDN pin = "H"), and the analog output becomes the VCOM voltage. After MCLK is input again, the AK4345 is powered up. After exiting reset by PDN pin at power-up etc., the AK4345 is in the reset mode until MCLK and LRCK are input.

Mode	DFS1	DFS0	fs	MCLK Frequency
Normal Speed	0	0	8 ~ 48kHz	256/384/512/768fs
Double Speed	0	1	48 ~ 96kHz	128/192/256/384fs
Half Speed	1	0	8 ~ 24kHz	512/768/1024/1536fs
Auto	1	1	8 ~ 96kHz	Table 2

Table 1. System Clock Example

MCLK Frequency	Sampling Speed Mode	Fs
512/768fs	Normal Speed	8 ~ 48kHz
128/192/256/384fs	Double Speed	48 ~ 96kHz
1024/1536fs	Half Speed	8 ~ 24kHz

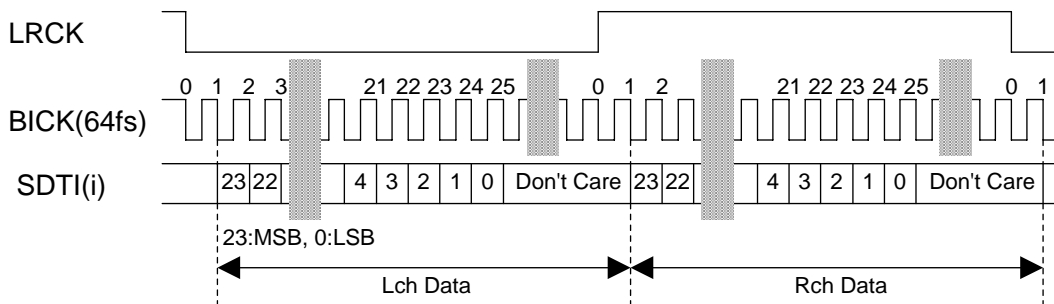
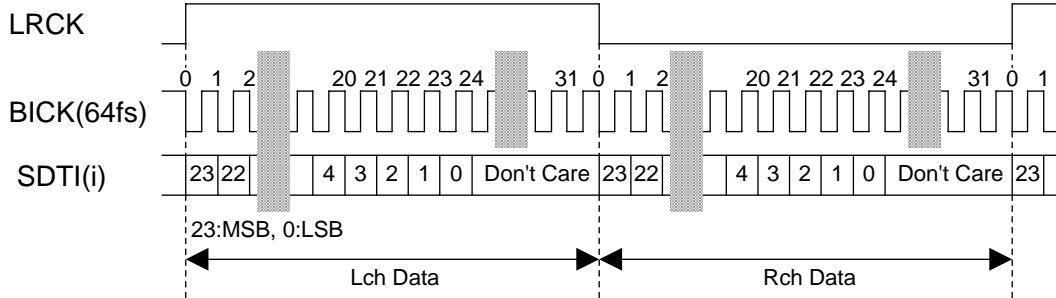
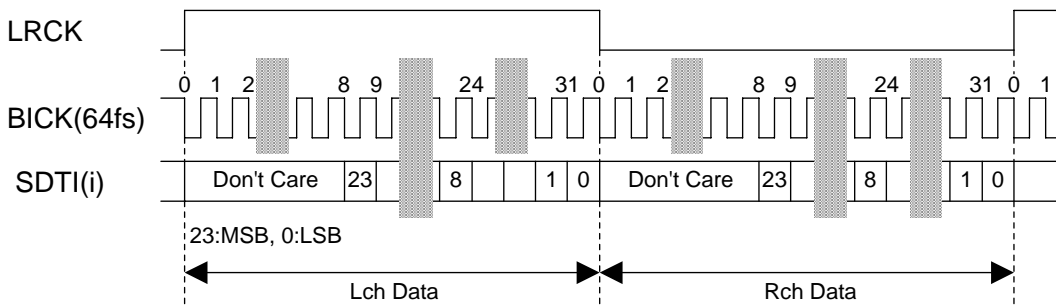
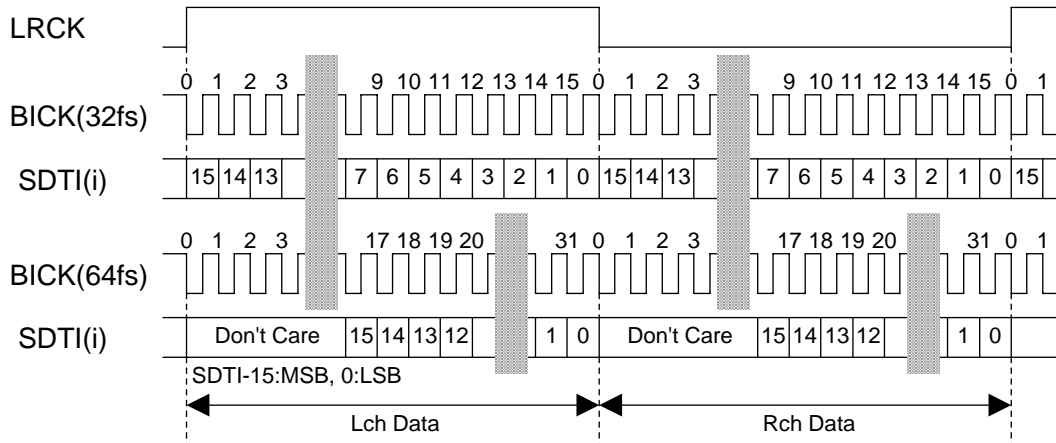
Table 2. Auto Mode

■ Audio Interface Format

The Data is shifted in via the SDTI pin using BICK and LRCK inputs. The DIF1-0 bits as shown in Table 3 can select four serial data modes. In all modes the serial data is MSB-first, 2's compliment format and is latched on the rising edge of BICK. Mode 3 can be used for 16bit I²S Compatible format by zeroing the unused LSBs at BICK ≥ 48fs or BICK = 32fs.

Mode	DIF1	DIF0	SDTI Format	BICK	Figure
0	0	0	16bit, LSB justified	≥ 32fs	Figure 10
1	0	1	24bit, LSB justified	≥ 48fs	Figure 11
2	1	0	24bit, MSB justified	≥ 48fs	Figure 12
3	1	1	16/24bit, I ² S Compatible	≥ 48fs or 32fs	Figure 13

Table 3. Audio Interface Format



■ Data Transmission Format

Data transmitted on the TX outputs is formatted in blocks as shown in Figure 14. Each block consists of 192 frames. A frame of data contains two sub-frames. A sub-frame consists of 32 bits of information. Each received data bit is coded using a bi-phase mark encoding as a two binary state symbol. The preambles violate bi-phase encoding so they may be differentiated from data. In bi-phase encoding, the first state of an input symbol is always the inverse of the last state of the previous data symbol. For a logic 0, the second state of the symbol is the same as the first state. For a logic 1, the second state is the opposite of the first. Figure 15 illustrates a sample stream of 8 data bits encoded in 16 symbol states.

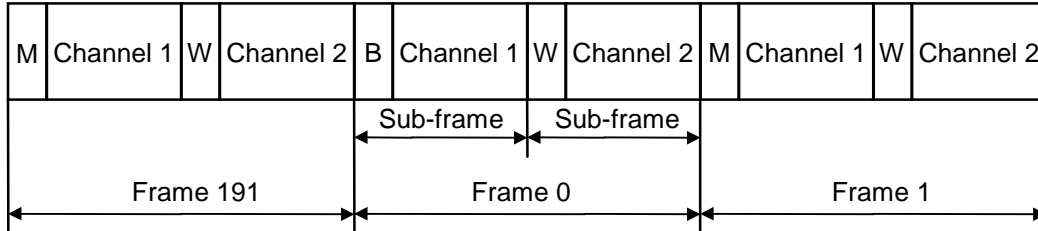


Figure 14. Block format

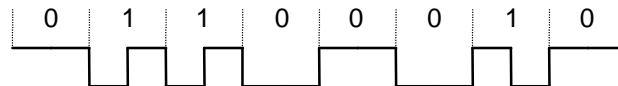


Figure 15. A biphas-encoded bit stream

The sub-frame is defined in Figure 16 below. Bits 0-3 of the sub-frame represent a preamble for synchronization. There are three preambles. The block preamble, B, is contained in the first sub-frame of Frame 0. The channel 1 preamble, M, is contained in the first sub-frame of all other frames. The channel 2 preamble, W, is contained in all of the second sub-frames.

Table 4 below defines the symbol encoding for each of the preambles. Bits 4-27 of the sub-frame contain the 24 bit audio sample in 2's complement format with bit 27 as the most significant bit. For 16 bit mode, Bits 4-11 are all 0. Bit 28 is the validity flag. This is "H" if the audio sample is unreliable. Bit 29 is a user data bit. Frame 0 contains the first bit of a 192 bit user data word. Frame 191 contains the last bit of the user data word. Bit 30 is a channel status bit. Again frame 0 contains the first bit of the 192 bit word with the last bit in frame 191. Bit 31 is an even parity bit for bits 4-31 of the sub-frame.

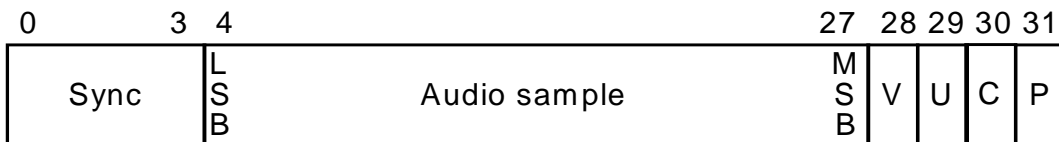


Figure 16. Sub-frame format

The block of data contains consecutive frames transmitted at a state-bit rate of 64 times the sample frequency, f_s . For stereophonic audio, the left or A channel data is in channel 1 while the right or B data is in channel 2. For monophonic audio, channel 1 contains the audio data.

Preamble	Preceding state = 0	Preceding state = 1
B	11101000	00010111
M	11100010	00011101
W	11100100	00011011

Table 4. Sub-frame preamble encoding

■ Channel Status bit

In the consumer mode (bit0 = "0"), bits20-23(audio channel) must be controlled by the CS20 bit. When the CS20 bit is "1", the AK4345 corresponds to "stereo mode", bits20-23 are set to "1000"(left channel) in sub-frame 1, and is set to "0100"(right channel) in sub-frame 2. When the CS20 bit is "0", bits20-23 is set to "0000" in both sub-frame 1 and sub-frame 2.

■ De-emphasis Filter

A digital de-emphasis filter is available for 32, 44.1 or 48kHz sampling rates ($t_c = 50/15\mu s$) and is controlled by DEM0 and DEM1. In double speed and quad speed mode, the digital de-emphasis filter is always off.

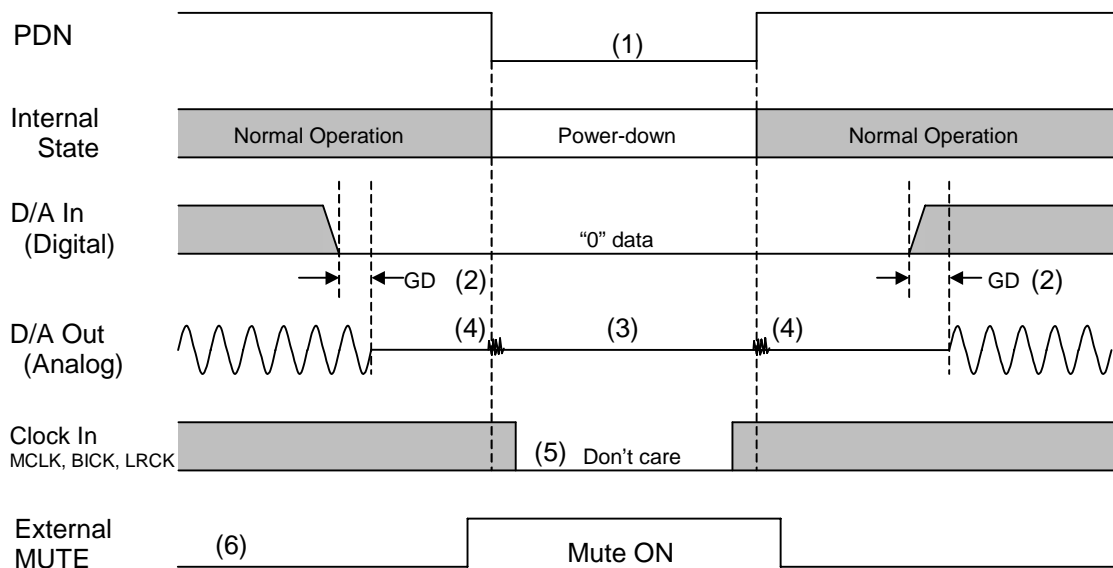
DEM1	DEM0	Mode
0	0	44.1kHz
0	1	OFF
1	0	48kHz
1	1	32kHz

(default)

Table 5. De-emphasis Filter Control (Normal Speed Mode)

■ Power-down

The AK4345 is placed in the power-down mode by bringing PDN pin = "L". and the digital filter is reset at the same time. This reset should always be done after power up.



Notes:

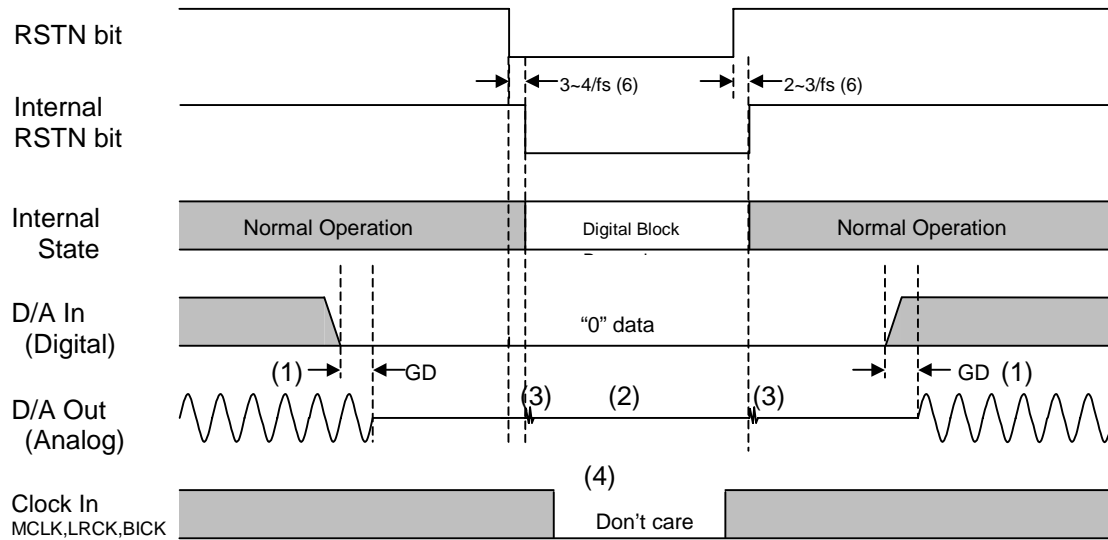
- (1) PDN pin should be "L" for 19ms or more when an electrolytic capacitor 4.7 μF is attached between VCOM pin and VSS.
- (2) The analog output corresponding to digital input has the group delay (GD).
- (3) When PDN pin = "L", the analog output is Hi-Z.
- (4) Click noise occurs in 3 ~ 4LRCK at both edges ($\uparrow \downarrow$) of PDN signal. This noise is output even if "0" data is input.
- (5) The external clocks (MCLK, BICK and LRCK) can be stopped in the power down mode (PDN pin = "L").
- (6) Please mute the analog output externally if the click noise (4) influences system application. The timing example is shown in this figure.

Figure 17. Power-down/up sequence example

■ Reset Function

(1) Reset by RSTN bit

When RSTN bit = 0, DAC is powered down but the internal register values are not initialized. The analog outputs go to VCOM voltage Figure 18 shows the example of reset by RSTN bit.



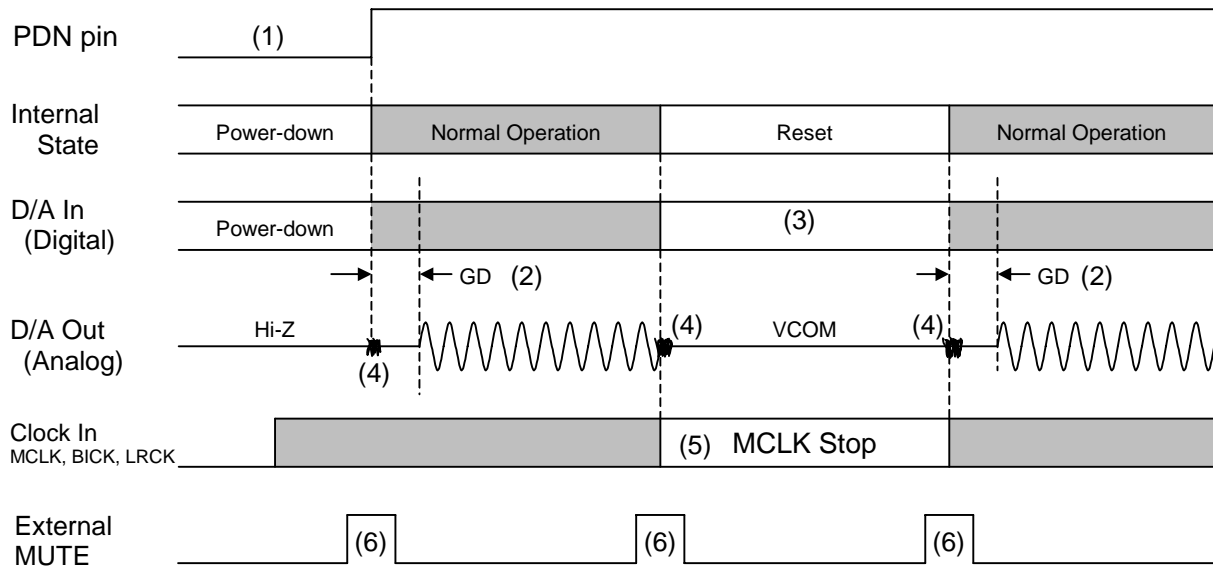
Notes:

- (1) The analog output corresponding to digital input has the group delay (GD).
- (2) Analog outputs go to VCOM voltage ($V_{DD}/2$).
- (3) Click noise occurs at the edges (“↑ ↓”) of the internal timing of RSTN bit. This noise is output even if “0” data is input.
- (4) The external clocks (MCLK, BICK and LRCK) can be stopped in the reset mode (RSTN bit = “0”).
- (5) There is a delay, $3 \sim 4/f_s$ from RSTN bit “0” to the internal RSTN bit “0”, and $2 \sim 3/f_s$ from RSTN bit “1” to the internal RSTN bit “1”.

Figure 18. Reset Sequence Example1

(2) RESET by MCLK stop (PDN pin = "H")

When MCLK stops, DAC is powered down but the internal register values are not initialized. The analog outputs go to VCOM voltage.



Notes:

- (1) PDN pin should be "L" for 19ms or more when an electrolytic capacitor 4.7 μ F is attached between VCOM pin and VSS.
- (2) The analog output corresponding to digital input has the group delay (GD).
- (3) The digital data can be stopped. The click noise after MCLK is input again by inputting the "0" data to this section can be reduced.
- (4) Click noise occurs in 3 ~ 4LRCK at both edges (\uparrow \downarrow) of PDN signal, MCLK inputs and MCLK stops. This noise is output even if "0" data is input.
- (5) The external clocks (BICK and LRCK) can be stopped in the power down mode (MCLK stop).
- (6) Please mute the analog output externally if the click noise (4) influences system application. The timing example is shown in this figure.

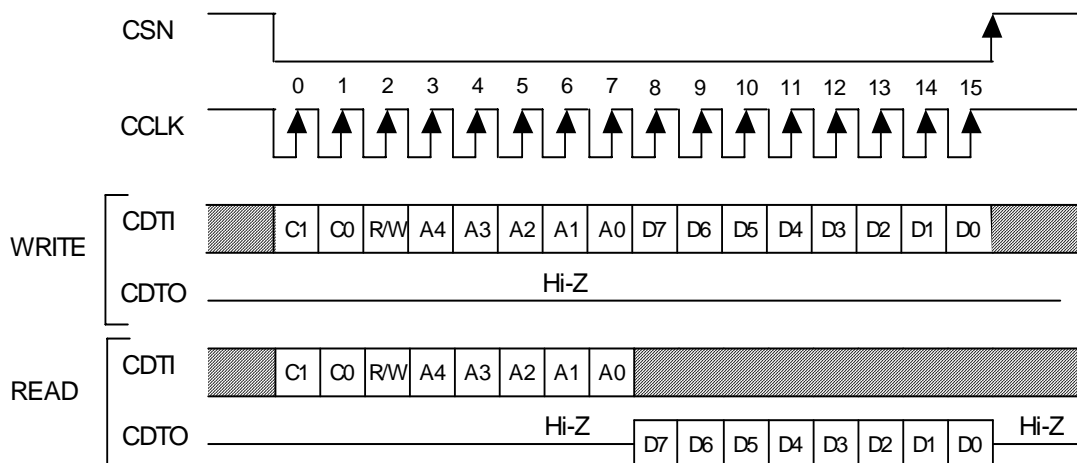
Figure 19. Reset Sequence Example 2

■ μ P Control Interface

The AK4345 can select 4-wire μ P I/F mode (MODE bit = "0") or 3-wire μ P I/F mode (MODE bit = "1").

1.4-wire μ P I/F mode (MODE bit = "0", default)

The internal registers may be either written or read by the 4-wire μ P interface pins: CSN, CCLK, CDTI and CDTO. The data on this interface consists of Chip address (2bits, C1/0; fixed to "01"), Read/Write (1bit), Register address (MSB first, 5bits) and Control data (MSB first, 8bits). Address and data are clocked in on the rising edge of CCLK and data is clocked out on the falling edge. For write operations, data is latched after the 16th rising edge of CCLK, after a high-to-low transition of CSN. CSN should be set to "H" once after 16 CCLKs. For read operations, the CDTO output goes high impedance after a low-to-high transition of CSN. The maximum speed of CCLK is 5MHz. PDN pin = "L" resets the registers to their default values.



C1-C0: Chip Address: (Fixed to "01")
 R/W: READ/WRITE (0:READ, 1:WRITE)
 A4-A0: Register Address
 D7-D0: Control Data

Figure 20. 4-wire Serial Control I/F Timing

*When the AK4345 is in the power down mode (PDN pin = "L") or the MCLK is not provided, writing into the control register is inhibited.

2.3-wire μ P I/F mode (MODE bit = "1")

Internal registers may be written by 3-wire μ P interface pins, CSN, CCLK and CDTI. The data on this interface consists of Chip Address (2bits, C1/0; fixed to "01"), Read/Write (1bit; fixed to "1", Write only), Register Address (MSB first, 5bits) and Control Data (MSB first, 8bits). AK4345 latches the data on the rising edge of CCLK, so data should be clocked in on the falling edge. The writing of data becomes valid by 16th CCLK after a high to low transition of CSN. CSN should be set to "H" once after 16 CCLKs for each address. The clock speed of CCLK is 5MHz (max).

PDN pin = "L" resets the registers to their default values. The internal timing circuit is reset by RSTN bit, but the registers are not initialized.

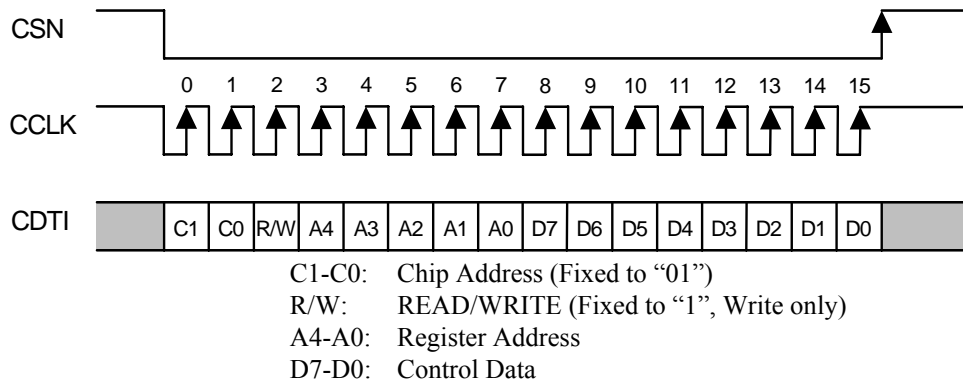


Figure 21. Control I/F Timing

*The AK4345 does not support the read command and chip address. C1/0 and R/W are fixed to "011"

*When the AK4345 is in the power down mode (PDN pin = "L") or the MCLK is not provided, writing into the control register is inhibited.

■ DAC and DIT input select

The AK4345 can select 4-wire μ P I/F mode (MODE bit = "0") or 3-wire μ P I/F mode (MODE bit = "1"). In 3-wire μ P I/F mode, the AK4345 can select the input data of DAC and DIT from SDTI1 or SDTI2 data.

MODE	SEL1	SEL0	μ P I/F	DAC input	DIT input
0	x	x	4-wire	SDTI1	SDTI1
1	0	0	3-wire	SDTI1	SDTI1
1	0	1	3-wire	SDTI2	SDTI2
1	1	0	3-wire	SDTI2	Bypass
1	1	1	Reserved		

(x: Don't care)

Table 6. DAC and DIT Input

■ Register Map

Addr	Register Name	D7	D6	D5	D4	D3	D2	D1	D0
00H	Control 1	1	0	0	0	DIF1	DIF0	PW	RSTN
01H	Control 2	0	1	0	DFS1	DFS0	DEM1	DEM0	GAIN
02H	Control 3	0	0	0	INVL	INVR	MODE	SEL1	SEL0
03H	TX	0	0	0	0	0	0	V	TXE
04H	Channel Status Byte0	CS7	CS6	CS5	CS4	CS3	CS2	CS1	CS0
05H	Channel Status Byte1	CS15	CS14	CS13	CS12	CS11	CS10	CS9	CS8
06H	Channel Status Byte2	CS23	CS22	CS21	CS20	CS19	CS18	CS17	CS16
07H	Channel Status Byte3	CS39	CS38	CS37	CS36	CS35	CS34	CS33	CS32
08H	Channel Status Byte4	CS39	CS38	CS37	CS36	CS35	CS34	CS33	CS32
09H	Channel Status Byte5	0	0	0	0	0	0	CS41	CS40

Notes:

For addresses from 0AH to 1FH, data must not be written.

When PDN pin goes “L”, the registers are initialized to their default values.

When RSTN bit goes “0”, the only internal timing is reset and the registers are not initialized to their default values. All data can be written to the register even if PW or RSTN bit is “0”.

The bits shown as “0” should be written “0” and the bits shown as “1” should be written “1”.

■ Register Definitions

Addr	Register Name	D7	D6	D5	D4	D3	D2	D1	D0
00H	Control 1	1	0	0	0	DIF1	DIF0	PW	RSTN
	R/W	R/W							
	Default	1	0	0	0	1	1	1	1

RSTN: Internal timing reset control

0: Reset. All registers are not initialized.

1: Normal Operation

When MCLK frequency or DFS changes the click noise occurs. It can be reduced by RSTN bit.

PW: Power down control

0: Power down. All registers are not initialized.

1: Normal Operation

DIF1-0: Audio data interface formats (Table 3)

Initial: “11”, Mode 3

Addr	Register Name	D7	D6	D5	D4	D3	D2	D1	D0
01H	Control 2	0	1	0	DFS1	DFS0	DEM1	DEM0	GAIN
R/W		R/W							
Default		0	1	0	1	1	0	1	1

DEM1-0: De-emphasis Response (Table 5)
Initial: "01", OFF

DFS1-0: Sampling speed control

00: Normal speed

01: Double speed

10: Half speed

11: Auto (default)

When changing between Normal/Double Speed Mode and Half Speed Mode, some click noise occurs.

GAIN: Output Voltage scale

0: $V_{out} = 0.67 \times V_{DD}$ (typ) at Full-scale voltage (0dB) .

1: $V_{out} = 0.85 \times V_{DD}$ (typ) at Full-scale voltage (0dB) .

	Register Name	D7	D6	D5	D4	D3	D2	D1	D0
02H	Control 3	0	0	0	INVL	INVR	MODE	SEL1	SEL0
R/W		R/W							
Default		0	0	0	0	0	0	0	0

INVR: Inverting Lch Output Polarity

0: Normal Output

1: Inverted Output

INVL: Inverting Rch Output Polarity

0: Normal Output

1: Inverted Output

MODE: Mode Control

0: 4 wire mode

1: 3 wire mode

SEL1-0: DAC and DIT input

00: SDTI1 input

01: SDTI2 input

10: SDTI2 input (DIT Bypass)

11: Reserved

SEL1-0 bits are disabled in 4-wire μ P I/F mode (MODE bit = "0").

SDTI1 data is input to both DAC and DIT.

	Register Name	D7	D6	D5	D4	D3	D2	D1	D0
03H	TX	1	0	0	0	0	0	V	TXE
	R/W	R/W							
	Default	1	0	0	0	0	0	0	1

V: Validity Flag

0: Valid

1: Invalid

TXE: TX output

0: "L"

1: Normal Operation

	Register Name	D7	D6	D5	D4	D3	D2	D1	D0
04H	Channel Status Byte0	CS7	CS6	CS5	CS4	CS3	CS2	CS1	CS0
	Default	0	0	0	0	0	1	0	0
05H	Channel Status Byte1	CS15	CS14	CS13	CS12	CS11	CS10	CS9	CS8
	Default	0	0	0	0	0	0	0	0
06H	Channel Status Byte2	CS23	CS22	CS21	CS20	CS19	CS18	CS17	CS16
	Default	0	0	0	0	0	0	0	0
07H	Channel Status Byte3	CS31	CS30	CS29	CS28	CS27	CS26	CS25	CS24
	Default	0	0	0	0	0	0	0	0
08H	Channel Status Byte4	CS39	CS38	CS37	CS36	CS35	CS34	CS33	CS32
	Default	0	0	0	0	0	0	0	0
09H	Channel Status Byte5	0	0	0	0	0	0	CS41	CS40
	Default	0	0	0	0	0	0	0	0

CS7-0: Transmitter Channel Status Byte 0

Default: "00000100"

CS39-8: Transmitter Channel Status Byte 4-1

Default: "00000000"

CS41-CS40: Transmitter Channel Status Byte 5

Default: "00000000", D7-D2 bits should be written "0".

SYSTEM DESIGN

Figure 22 and Figure 23 shows the system connection diagram. The evaluation board is available which demonstrates application circuits, the optimum layout, power supply arrangements and measurement results.

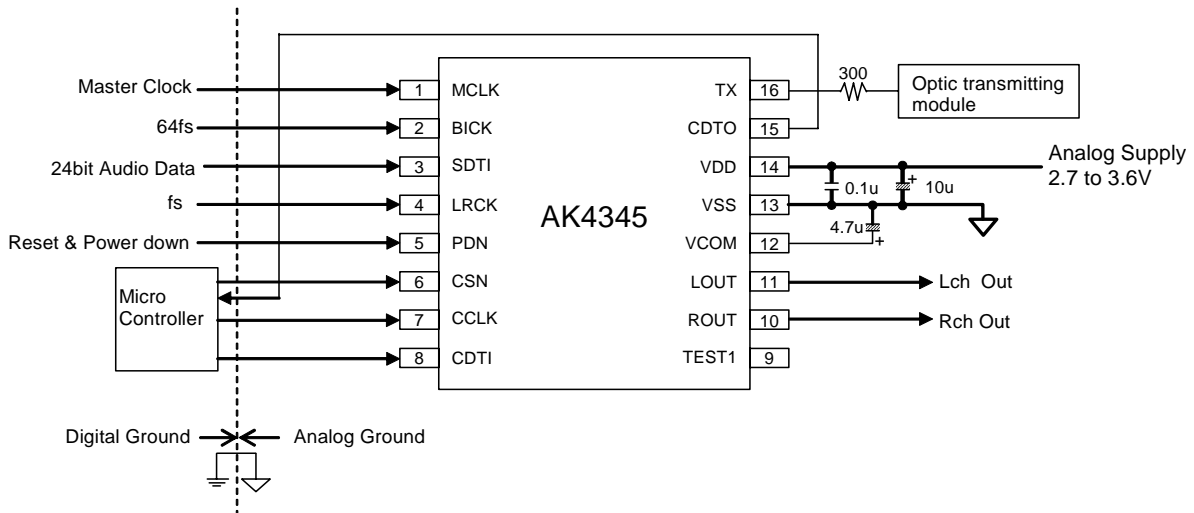


Figure 22. Typical Connection Diagram (Mode bit = "0", 4 wire mode)

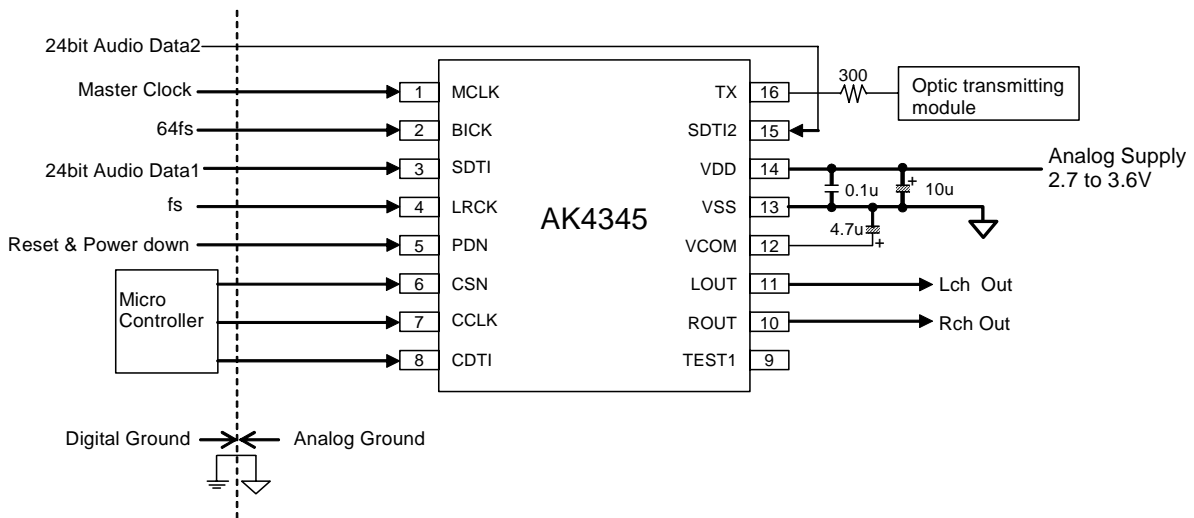


Figure 23. Typical Connection Diagram (Mode bit = "1", 3 wire mode)

1. Grounding and Power Supply Decoupling

The AK4345 requires careful attention for power supply and grounding arrangements. VDD is usually supplied from the analog supply in the system. System analog ground and digital ground should be connected together near to where the supplies are brought onto the printed circuit board. Decoupling capacitors should be as near to the AK4345 as possible, with the small value ceramic capacitor being the closest.

2. Voltage Reference

The differential Voltage between VDD and VSS sets the analog output range. VCOM is used as a common voltage of the analog signal. VCOM pin is a signal ground of this chip. An electrolytic capacitor about $4.7\mu\text{F}$ should be attached between VCOM pin and VSS. No load current may be drawn from VCOM pin. Especially, the ceramic capacitor should be connected to this pin as near as possible.

3. Analog Outputs

The analog outputs are single-ended and centered around the VCOM voltage ($0.5 \times \text{VDD}$). The output signal range is typically 2.8Vpp (typ@VDD=3.3V). The internal switched-capacitor filter and continuous-time filter attenuate the noise generated by the delta-sigma modulator beyond the audio passband. The output voltage is a positive full scale for 7FFFFFFH (@24bit) and a negative full scale for 800000H (@24bit). The ideal output is VCOM voltage ($0.5 \times \text{VDD}$) for 000000H (@24bit).

DC offsets on analog outputs are eliminated by AC coupling since analog outputs have DC offsets of VCOM + a few mV. Figure 24 shows an example of the external LPF with 2.8Vpp (1Vrms) output.

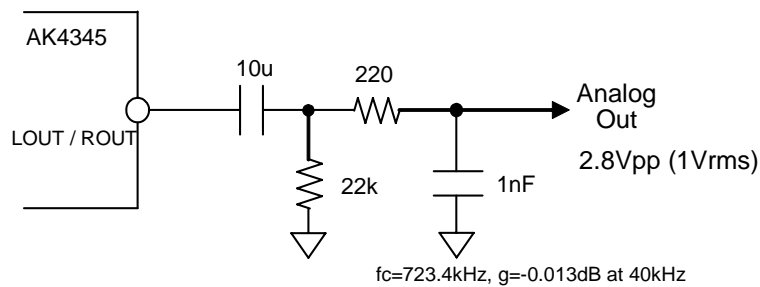
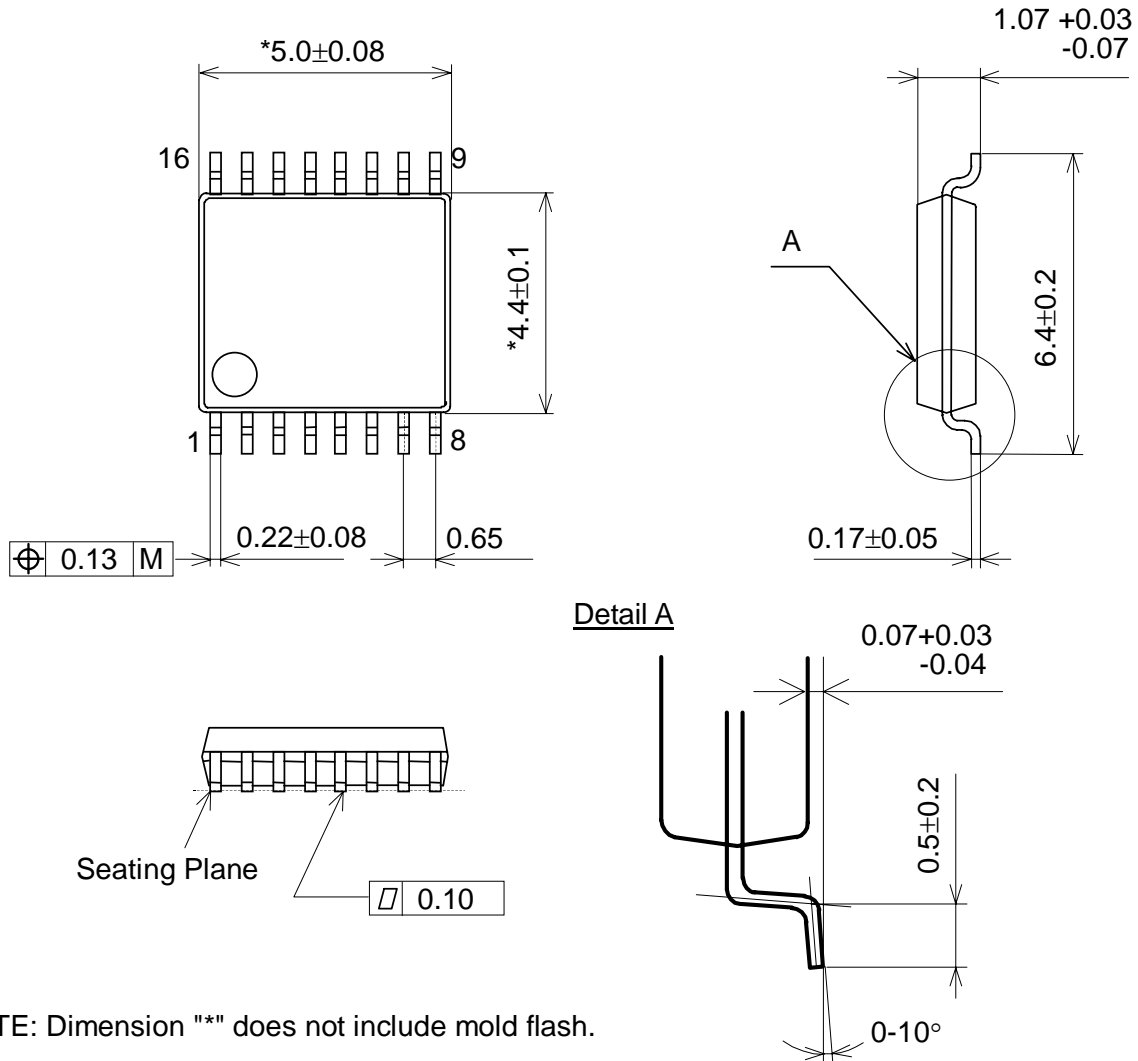


Figure 24. External 1st order LPF Circuit Example

PACKAGE

16pin TSSOP (Unit: mm)

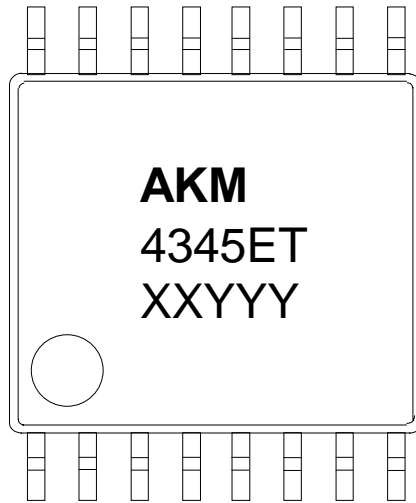


NOTE: Dimension "*" does not include mold flash.

■ Package & Lead frame material

Package molding compound:	Epoxy
Lead frame material:	Cu
Lead frame surface treatment:	Solder (Pb free) plate

MARKING



- 1) Pin #1 indication
- 2) Date Code : XXYYY (5 digits)
 XX: Lot#
 YYY: Date Code
- 3) Marketing Code : 4345ET
- 4) Asahi Kasei Logo

REVISION HISTORY

Date (YY/MM/DD)	Revision	Reason	Page	Contents
07/06/20	00	First Edition		

IMPORTANT NOTICE

- These products and their specifications are subject to change without notice.
 When you consider any use or application of these products, please make inquiries the sales office of Asahi Kasei EMD Corporation (AKEMD) or authorized distributors as to current status of the products.
- AKEMD assumes no liability for infringement of any patent, intellectual property, or other rights in the application or use of any information contained herein.
- Any export of these products, or devices or systems containing them, may require an export license or other official approval under the law and regulations of the country of export pertaining to customs and tariffs, currency exchange, or strategic materials.
- AKEMD products are neither intended nor authorized for use as critical components_{Note1)} in any safety, life support, or other hazard related device or system_{Note2)}, and AKEMD assumes no responsibility for such use, except for the use approved with the express written consent by Representative Director of AKEMD. As used here:
 Note1) A critical component is one whose failure to function or perform may reasonably be expected to result, whether directly or indirectly, in the loss of the safety or effectiveness of the device or system containing it, and which must therefore meet very high standards of performance and reliability.
 Note2) A hazard related device or system is one designed or intended for life support or maintenance of safety or for applications in medicine, aerospace, nuclear energy, or other fields, in which its failure to function or perform may reasonably be expected to result in loss of life or in significant injury or damage to person or property.
- It is the responsibility of the buyer or distributor of AKEMD products, who distributes, disposes of, or otherwise places the product with a third party, to notify such third party in advance of the above content and conditions, and the buyer or distributor agrees to assume any and all responsibility and liability for and hold AKEMD harmless from any and all claims arising from the use of said product in the absence of such notification.