



# STW54NK30Z

## N-CHANNEL 300V - 0.052Ω - 54A TO-247 Zener-Protected SuperMESH™ MOSFET

**Table 1: General Features**

TYPE	BV <sub>DSS</sub>	R <sub>DS(on)</sub>	I <sub>D</sub>	P <sub>w</sub>
STW54NK30Z	300 V	< 0.060 Ω	54 A	300 W

- TYPICAL R<sub>DS(on)</sub> = 0.052 Ω
- EXTREMELY HIGH dv/dt CAPABILITY
- 100% AVALANCHE TESTED
- GATE CHARGE MINIMIZED
- VERY LOW INTRINSIC CAPACITANCES
- VERY GOOD MANUFACTURING REPEATABILITY

### DESCRIPTION

The SuperMESH™ series is obtained through an extreme optimization of ST's well established strip-based PowerMESH™ layout. In addition to pushing on-resistance significantly down, special care is taken to ensure a very good dv/dt capability for the most demanding applications. Such series complements ST full range of high voltage MOSFETs including revolutionary MDmesh™ products.

### APPLICATIONS

- HIGH CURRENT, HIGH SPEED SWITCHING DC CHOPPERs
- IDEAL FOR OFF-LINE POWER SUPPLIES, ADAPTORS AND PFC

**Table 2: Order Codes**

SALES TYPE	MARKING	PACKAGE	PACKAGING
STW54NK30Z	W54NK30Z	TO-247	TUBE

**Figure 1: Package**

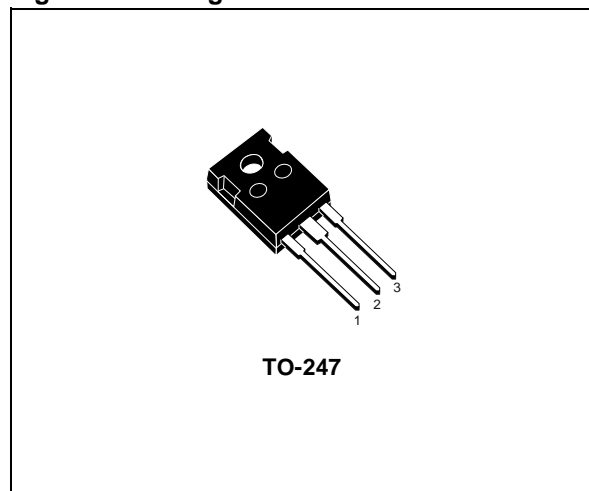

**Figure 2: Internal Schematic Diagram**

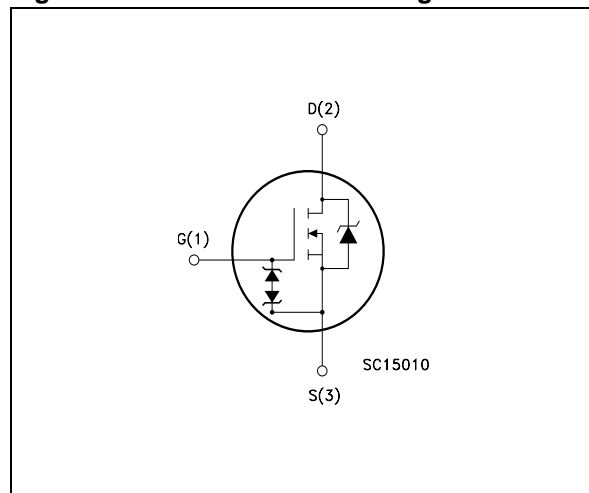

**Table 3: Absolute Maximum ratings**

Symbol	Parameter	Value	Unit
$V_{DS}$	Drain-source Voltage ( $V_{GS} = 0$ )	300	V
$V_{DGR}$	Drain-gate Voltage ( $R_{GS} = 20 \text{ k}\Omega$ )	300	V
$V_{GS}$	Gate- source Voltage	$\pm 30$	V
$I_D$	Drain Current (continuous) at $T_C = 25^\circ\text{C}$	54	A
$I_D$	Drain Current (continuous) at $T_C = 100^\circ\text{C}$	34	A
$I_{DM}(\bullet)$	Drain Current (pulsed)	200	A
$P_{TOT}$	Total Dissipation at $T_C = 25^\circ\text{C}$	300	W
	Derating Factor	2.38	$\text{W}^\circ\text{C}$
$V_{ESD(G-S)}$	Gate source ESD(HBM-C=100pF, R=1.5K $\Omega$ )	6000	V
$dv/dt(1)$	Peak Diode Recovery voltage slope	4.5	V/ns
$T_j$ $T_{stg}$	Operating Junction Temperature Storage Temperature	-55 to 150	$^\circ\text{C}$

( $\bullet$ ) Pulse width limited by safe operating area

(1)  $I_{SD} \leq 54\text{A}$ ,  $di/dt \leq 200\text{A}/\mu\text{s}$ ,  $V_{DD} \leq V_{(BR)DSS}$ ,  $T_j \leq T_{JMAX}$ .

(\*) Limited only by maximum temperature allowed

**Table 4: Thermal Data**

$R_{thj-case}$	Thermal Resistance Junction-case Max	0.42	$^\circ\text{C}/\text{W}$
$R_{thj-amb}$ $T_I$	Thermal Resistance Junction-ambient Max Maximum Lead Temperature For Soldering Purpose	30 300	$^\circ\text{C}/\text{W}$ $^\circ\text{C}$

**Table 5: Avalanche Characteristics**

Symbol	Parameter	Max Value	Unit
$I_{AR}$	Avalanche Current, Repetitive or Not-Repetitive (pulse width limited by $T_j$ max)	54	A
$E_{AS}$	Single Pulse Avalanche Energy (starting $T_j = 25^\circ\text{C}$ , $I_D = I_{AR}$ , $V_{DD} = 50 \text{ V}$ )	400	mJ

**Table 6: Gate-Source Zener Diode**

Symbol	Parameter	Test Conditions	Min.	Typ.	Max.	Unit
$BV_{GSO}$	Gate-Source Breakdown Voltage	$I_{gs} = \pm 1 \text{ mA}$ (Open Drain)	30			V

## PROTECTION FEATURES OF GATE-TO-SOURCE ZENER DIODES

The built-in back-to-back Zener diodes have specifically been designed to enhance not only the device's ESD capability, but also to make them safely absorb possible voltage transients that may occasionally be applied from gate to source. In this respect the Zener voltage is appropriate to achieve an efficient and cost-effective intervention to protect the device's integrity. These integrated Zener diodes thus avoid the usage of external components.

**ELECTRICAL CHARACTERISTICS** ( $T_{CASE} = 25^{\circ}C$  UNLESS OTHERWISE SPECIFIED)**Table 7: On/Off**

Symbol	Parameter	Test Conditions	Min.	Typ.	Max.	Unit
$V_{(BR)DSS}$	Drain-source Breakdown Voltage	$I_D = 1 \text{ mA}, V_{GS} = 0$	300			V
$I_{DSS}$	Zero Gate Voltage Drain Current ( $V_{GS} = 0$ )	$V_{DS} = \text{Max Rating}$ $V_{DS} = \text{Max Rating}, T_C = 125^{\circ}C$			1 50	$\mu\text{A}$ $\mu\text{A}$
$I_{GSS}$	Gate-body Leakage Current ( $V_{DS} = 0$ )	$V_{GS} = \pm 20\text{V}$			$\pm 10$	$\mu\text{A}$
$V_{GS(th)}$	Gate Threshold Voltage	$V_{DS} = V_{GS}, I_D = 150 \mu\text{A}$	3	3.75	4.5	V
$R_{DS(on)}$	Static Drain-source On Resistance	$V_{GS} = 10\text{V}, I_D = 27 \text{ A}$		0.052	0.060	$\Omega$

**Table 8: Dynamic**

Symbol	Parameter	Test Conditions	Min.	Typ.	Max.	Unit
$g_{fs} (1)$	Forward Transconductance	$V_{DS} = 15 \text{ V}, I_D = 27 \text{ A}$		25		S
$C_{iss}$ $C_{oss}$ $C_{rss}$	Input Capacitance Output Capacitance Reverse Transfer Capacitance	$V_{DS} = 25\text{V}, f = 1 \text{ MHz}, V_{GS} = 0$		4960 745 186		pF pF pF
$C_{oss \text{ eq.}} (3)$	Equivalent Output Capacitance	$V_{GS} = 0\text{V}, V_{DS} = 0\text{V to } 240 \text{ V}$		550		pF
$t_{d(on)}$ $t_r$ $t_{d(off)}$ $t_f$	Turn-on Delay Time Rise Time Turn-off Delay Time Fall Time	$V_{DD} = 150 \text{ V}, I_D = 27 \text{ A}$ $R_G = 4.7\Omega, V_{GS} = 10 \text{ V}$ (Resistive Load see, Figure 3)		40 45 116 35		ns ns ns ns
$Q_g$ $Q_{gs}$ $Q_{gd}$	Total Gate Charge Gate-Source Charge Gate-Drain Charge	$V_{DD} = 240\text{V}, I_D = 54\text{A},$ $V_{GS} = 10\text{V}$		158 30 90	221	nC nC nC

**Table 9: Source Drain Diode**

Symbol	Parameter	Test Conditions	Min.	Typ.	Max.	Unit
$I_{SD}$ $I_{SDM} (2)$	Source-drain Current Source-drain Current (pulsed)				54 200	A A
$V_{SD} (1)$	Forward On Voltage	$I_{SD} = 54 \text{ A}, V_{GS} = 0$			1.6	V
$t_{rr}$ $Q_{rr}$ $I_{RRM}$	Reverse Recovery Time Reverse Recovery Charge Reverse Recovery Current	$I_{SD} = 54 \text{ A}, di/dt = 100\text{A}/\mu\text{s}$ $V_{DD} = 100 \text{ V}, T_j = 25^{\circ}C$ (see test circuit, Figure 5)		328 2.8 17.2		ns $\mu\text{C}$ A
$t_{rr}$ $Q_{rr}$ $I_{RRM}$	Reverse Recovery Time Reverse Recovery Charge Reverse Recovery Current	$I_{SD} = 54 \text{ A}, di/dt = 100\text{A}/\mu\text{s}$ $V_{DD} = 100 \text{ V}, T_j = 150^{\circ}C$ (see test circuit, Figure 5)		416 4.2 20.2		ns $\mu\text{C}$ A

Note: 1. Pulsed: Pulse duration = 300  $\mu\text{s}$ , duty cycle 1.5 %.

2. Pulse width limited by safe operating area.

3.  $C_{oss \text{ eq.}}$  is defined as a constant equivalent capacitance giving the same charging time as  $C_{oss}$  when  $V_{DS}$  increases from 0 to 80%  $V_{DSS}$ .

Figure 3: Safe Operating Area

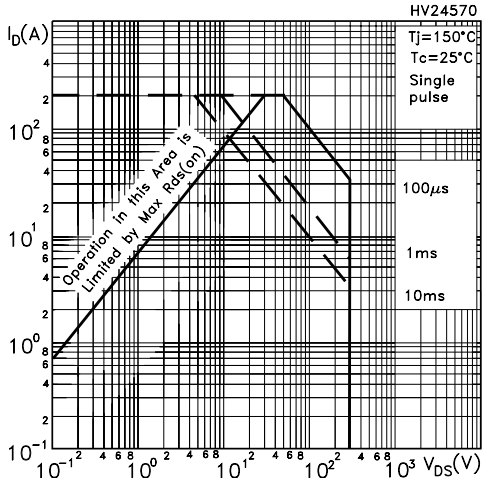

Figure 4: Output Characteristics

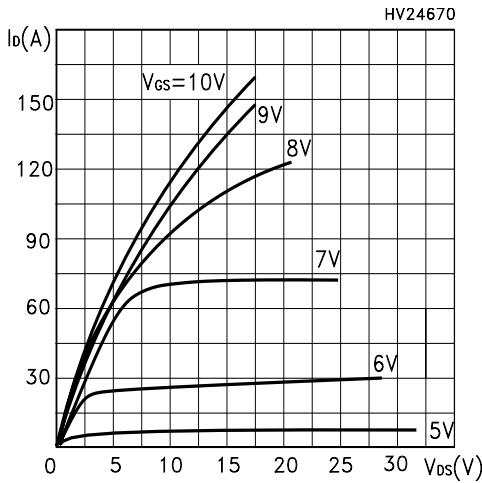

Figure 5: Transconductance

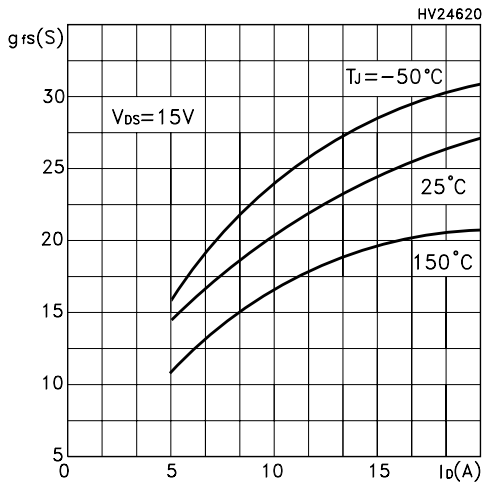

Figure 6: Thermal Impedance

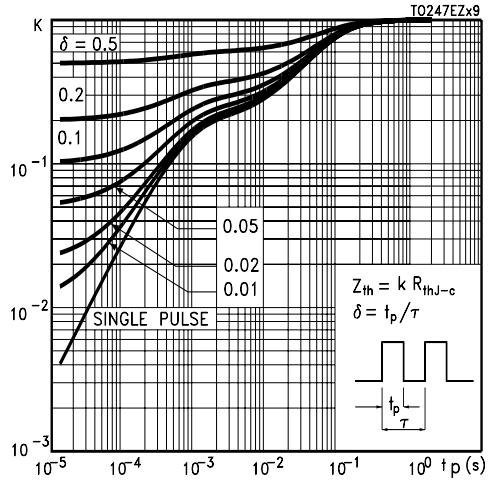

Figure 7: Transfer Characteristics

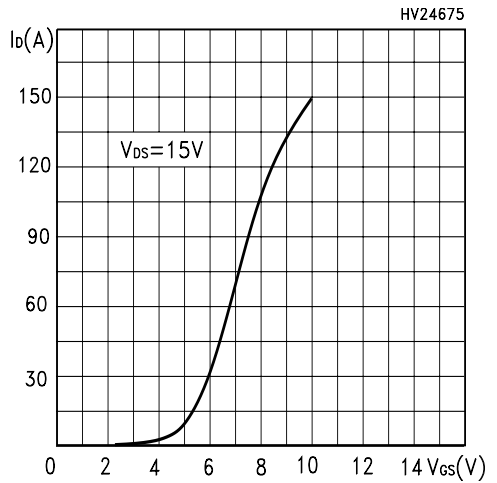

Figure 8: Static Drain-source On Resistance

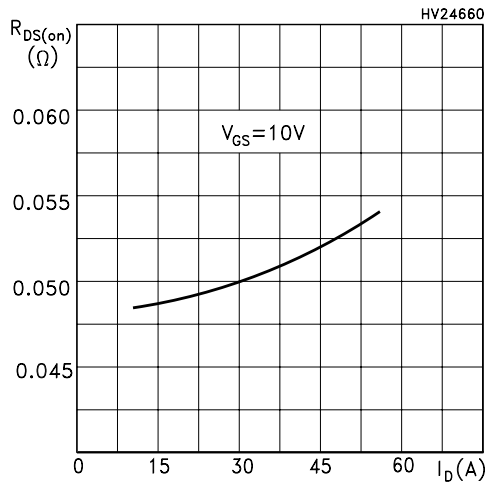

Figure 9: Gate Charge vs Gate-source Voltage

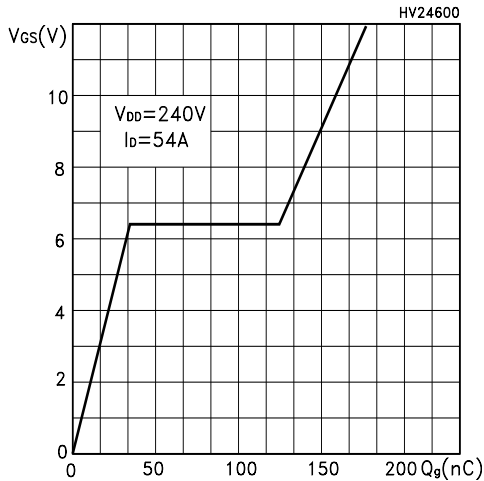

Figure 10: Normalized Gate Threshold Voltage vs Temperature

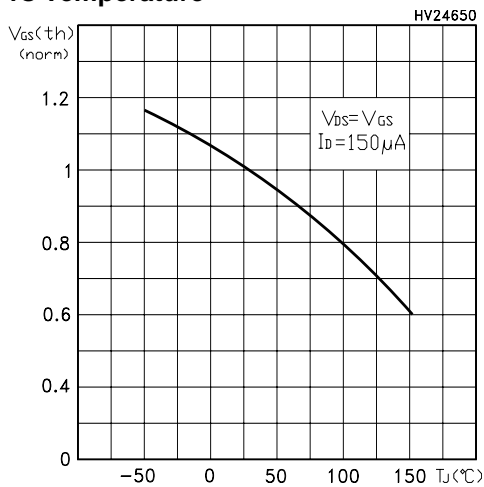

Figure 11: Source-Drain Diode Forward Characteristics

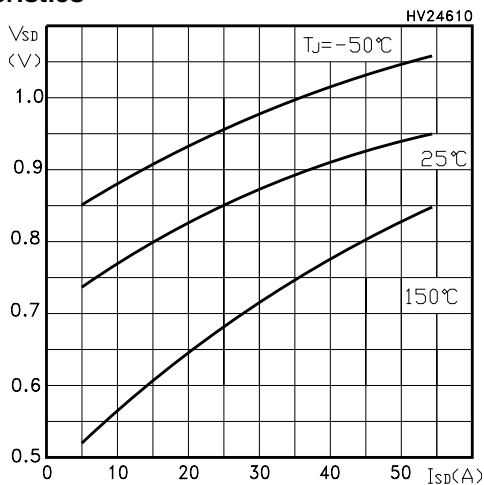

Figure 12: Capacitance Variations

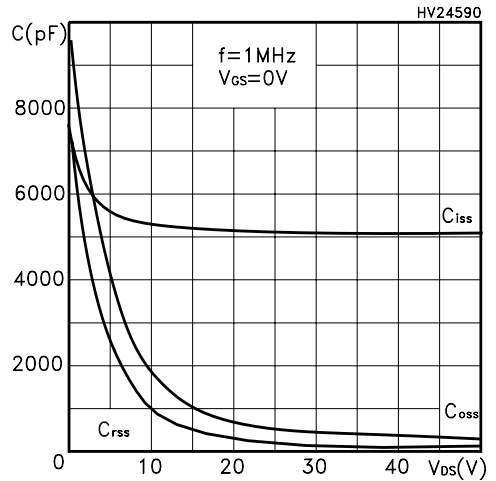

Figure 13: Normalized On Resistance vs Temperature

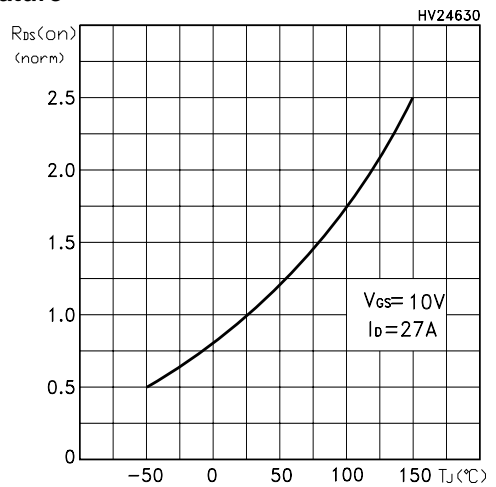

Figure 14: Normalized BVds vs Temperature

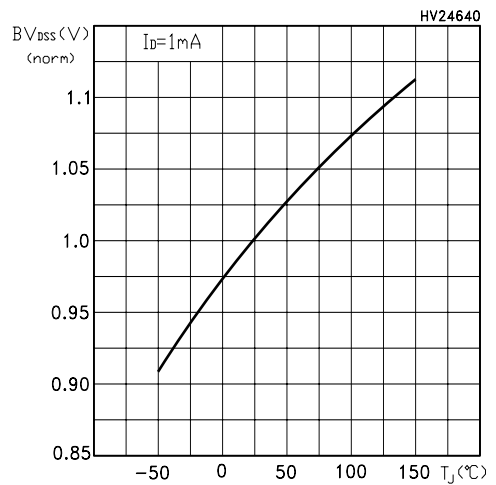

Figure 15: Avalanche Energy vs Starting Tj

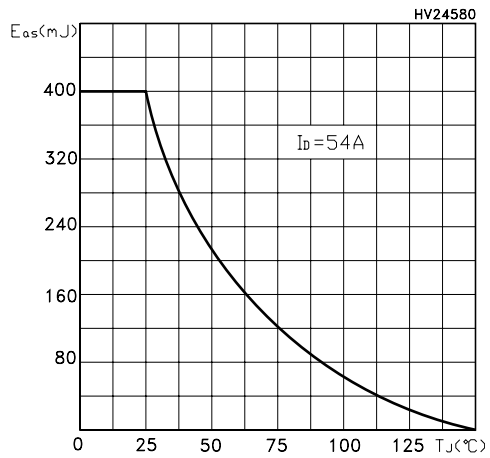

Figure 16: Unclamped Inductive Load Test Circuit

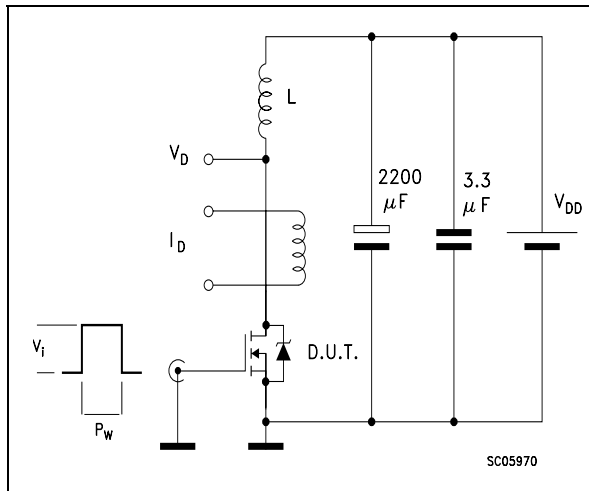

Figure 17: Switching Times Test Circuit For Resistive Load

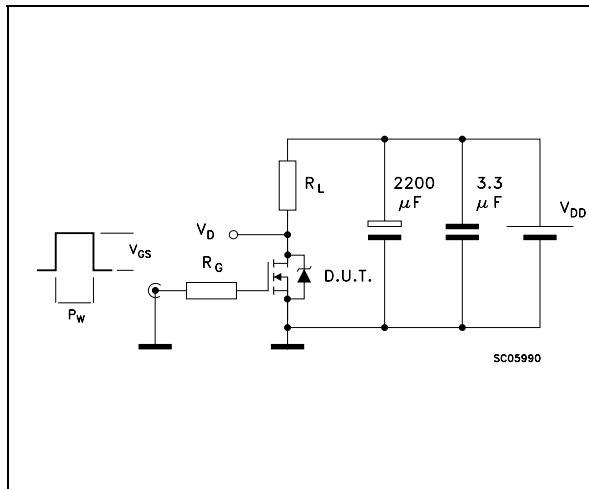

Figure 18: Test Circuit For Inductive Load Switching and Diode Recovery Times

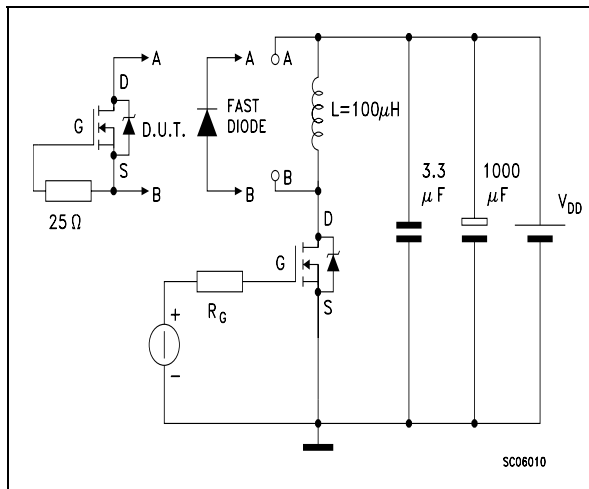

Figure 19: Unclamped Inductive Waferform

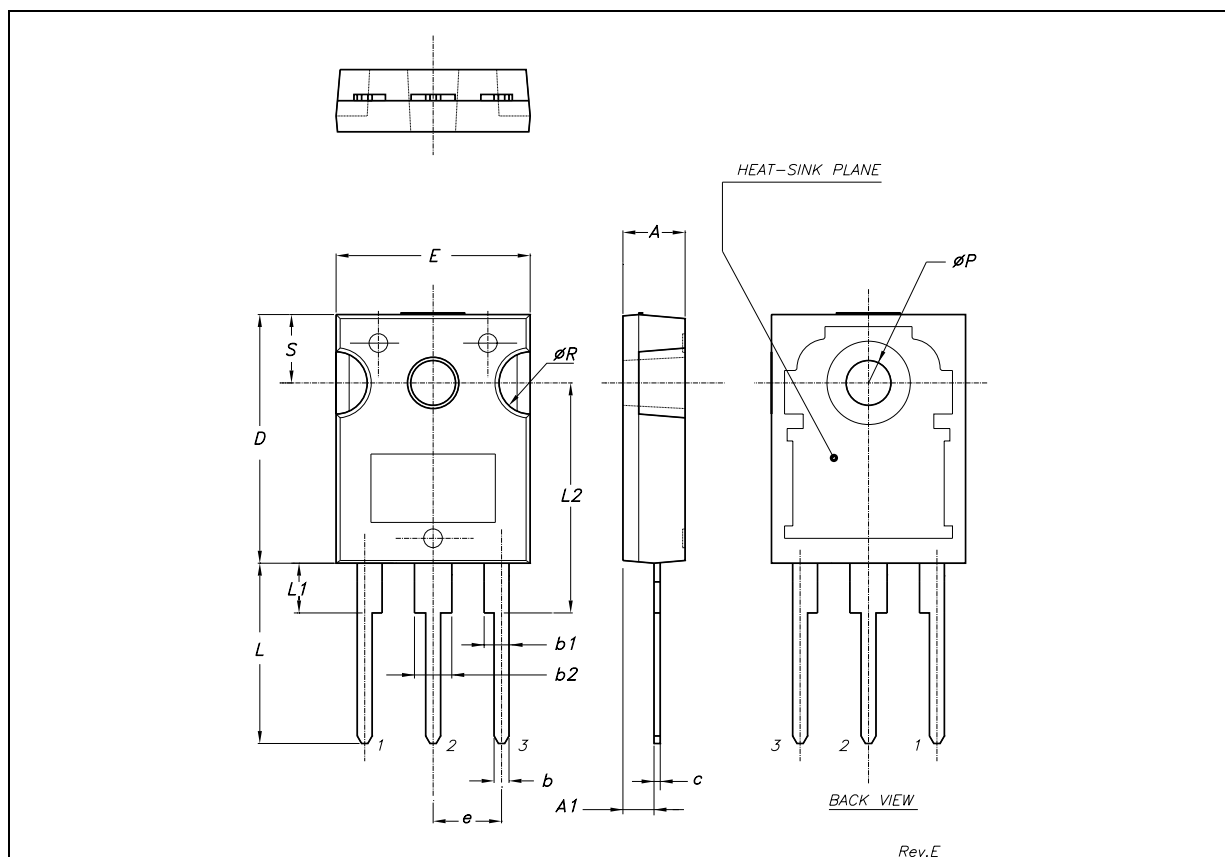

Figure 20: Gate Charge Test Circuit



## TO-247 MECHANICAL DATA

DIM.	mm.			inch		
	MIN.	TYP.	MAX.	MIN.	TYP.	MAX.
A	4.85		5.15	0.19		0.20
A1	2.20		2.60	0.086		0.102
b	1.0		1.40	0.039		0.055
b1	2.0		2.40	0.079		0.094
b2	3.0		3.40	0.118		0.134
c	0.40		0.80	0.015		0.03
D	19.85		20.15	0.781		0.793
E	15.45		15.75	0.608		0.620
e		5.45			0.214	
L	14.20		14.80	0.560		0.582
L1	3.70		4.30	0.14		0.17
L2		18.50			0.728	
øP	3.55		3.65	0.140		0.143
øR	4.50		5.50	0.177		0.216
S		5.50			0.216	





**Table 10: Revision History**

Date	Revision	Description of Changes
31-Jan-2005	1	Complete datasheet

Information furnished is believed to be accurate and reliable. However, STMicroelectronics assumes no responsibility for the consequences of use of such information nor for any infringement of patents or other rights of third parties which may result from its use. No license is granted by implication or otherwise under any patent or patent rights of STMicroelectronics. Specifications mentioned in this publication are subject to change without notice. This publication supersedes and replaces all information previously supplied. STMicroelectronics products are not authorized for use as critical components in life support devices or systems without express written approval of STMicroelectronics.

The ST logo is a registered trademark of STMicroelectronics

All other names are the property of their respective owners

© 2005 STMicroelectronics - All Rights Reserved

STMicroelectronics group of companies

Australia - Belgium - Brazil - Canada - China - Czech Republic - Finland - France - Germany - Hong Kong - India - Israel - Italy - Japan - Malaysia - Malta - Morocco - Singapore - Spain - Sweden - Switzerland - United Kingdom - United States of America