

VISION & IMAGING

CUSTOMER DATASHEET **CD6500-STV0672S-A**: October 1999

USB VGA Digital Camera Chipset VV6500 and STV0672

The USB camera chipsets from STMicroelectronics are at the heart of a variety of products which have proven to be highly successful in a demanding marketplace. Supported by comprehensive reference designs, technical backup and fully-featured software drivers, STMicroelectronics offers camera manufacturers the opportunity to benefit from rapid time to market with a product of proven quality.

The VV6500 is a ColorMOS™ digital CMOS sensor that delivers outstanding picture quality. This VGA-resolution sensor has been created specifically to meet the standards required for high quality personal video communications. This sensor features automatic black and dark level calibration to ensure optimum image quality.

The STV0672 (CPIA2) co-processor receives image data from the sensor, that is processed, compressed and passed to the USB port. It incorporates a digital video processor engine to perform automatic exposure, automatic gain control and automatic white balance, together with colour matrixing, gamma correction, aperture correction, automatic defect correction and noise cancellation logic. This data is passed to the proprietary video compression that delivers high frame rates with minimum impact on image quality. The USB interface supports USB isochronous data transfer mode, ensuring access to guaranteed bandwidth at all time, irrespective of how many peripherals are then added.

The chipset is backed by a fully-featured driver which provides a host of user-definable settings for optimum camera setup. The user interface supports a degree of customisation.

STMicroelectronics offers a range of support services to guarantee product quality, including test specifications and test software.



KEY FEATURES

- Real-time video - up to 15fps VGA (30fps CIF)
- Multiple output image formats supported
- USB 1.1 compliant
- High quality MPEG compression
- Isochronous and bulk USB modes supported
- Automatic black level calibration
- Automatic dark level calibration
- Full VfW and TWAIN driver support
- Integrated voltage regulation
- Minimal BOM for complete USB camera
- Programmable vendor ID

APPLICATIONS

- High quality PC Camera
- Biometric identification
- Toys and games
- Image capture systems

SPECIFICATIONS

Pixel resolution	640 x 480 (VGA)
Array size	1/3" lens format
Exposure control	Automatic (>1000000:1)
Gain control	Automatic (to +24dB)
Signal/Noise ratio	57dB
Supply voltage	4.1v-5.25v DC (internally regulated)
USB Compatibility	USB Specification V1.1 Meets full power management requirements with no external components
Supply current	100mA approximately
Operating temperature (ambient)	0°C - 40°C (for extended temp. info please contact STMicroelectronics)
Package type	VV6500C001: 48CLCC STV0672: 64TQFP



USB VGA Digital Camera Chipset
VV6500 and STV0672

EXAMPLE APPLICATIONS

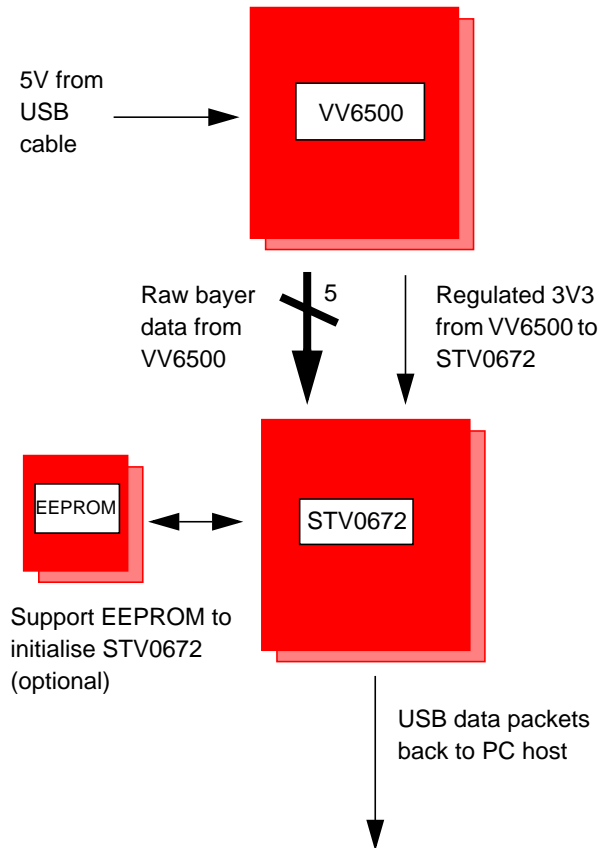

This chipset allows the implementation of a high quality PC camera with a minimum of external components. The support EEPROM is optionally populated if a custom USB enumeration sequence is required.

The STV0672 can perform inter-frame MPEG compression to a ratio of approximately 10:1. The companion ASIC can now also perform on the fly defect correction .

No transceivers are required to interface to the USB bus, and no external components are required to meet the power management requirements of the USB specification. VV6500 has an ultra low power mode where the sensor will consume less than 50uA.

ABOUT VISION & IMAGING TECHNOLOGY

Our unique CMOS technology enables integration of the sensor array and associated support circuitry on a single VLSI microchip. CMOS sensors are compact, highly integrated devices that require reduced power consumption over traditional CCD devices while offering equivalent image quality.

The VV6500 and STV0672 are part of a comprehensive range of image sensing and co-processor products from STMicroelectronics for applications including videoconferencing, digital stills cameras, toys, security and biometrics. Visit the VISION & IMAGING web site at www.vvl.co.uk for more information.

SUPPORT DOCUMENTATION

STMicroelectronics have produced comprehensive Reference Design documentation for design-in of this chipset. The reference design includes schematics, gerbers, BOM and documentation to allow the implementation of a full production-ready camera. Contact STMicroelectronics for further details.

ORDERING DETAILS

Part Number	Description
VV6500-C048	VGA resolution CMOS sensor, 48LCC package
STV0672-001	CPiA2 coprocessor
STV-USB/VGA-E01	USB chipset

Information furnished is believed to be accurate and reliable. However, STMicroelectronics assumes no responsibility for the consequences of use of such information nor for any infringement of patents or other rights of third parties which may result from its use. No license is granted by implication or otherwise under any patent or patent rights of STMicroelectronics. Specifications mentioned in this publication are subject to change without notice. This publication supersedes and replaces all information previously supplied. STMicroelectronics products are not authorized for use as critical components in life support devices or systems without express written approval of STMicroelectronics
 The ST logo is a registered trademark of STMicroelectronics
 © 1999 STMicroelectronics - All Rights Reserved