

FEATURES

- 25, 35, 45, and 55 ns Read Access & R/W Cycle Times
- Unlimited Read/Write Endurance
- Pin compatible with Industry Standard SRAMs
- Software-initiated Non-Volatile *STORE*
- Automatic *RECALL* to SRAM on Power Up
- Unlimited *RECALL* cycles
- 1 Million *STORE* Cycles
- 100-Year Non-volatile Data Retention
- Single 5V \pm 10% Operation
- Commercial, Industrial, and Military Temperatures
- 28 pin 330 mil SOIC (RoHS-Compatible)
- 28-pin CDIP and LCC packages

DESCRIPTION

The Simtek STK11C68 is a 64Kb fast static RAM with a nonvolatile Quantum Trap storage element included with each memory cell.

The SRAM provides the fast access & cycle times, ease of use, and unlimited read & write endurance of a normal SRAM.

Data transfers under software control to the non-volatile storage cells (the *STORE* operation). On power-up, data is automatically restored to the SRAM (the *RECALL* operation). *RECALL* operations are also available under software control.

The Simtek nvSRAM is the first monolithic non-volatile memory to offer unlimited writes and reads. It is the highest performance, most reliable non-volatile memory available.

BLOCK DIAGRAM

BLOCK DIAGRAM

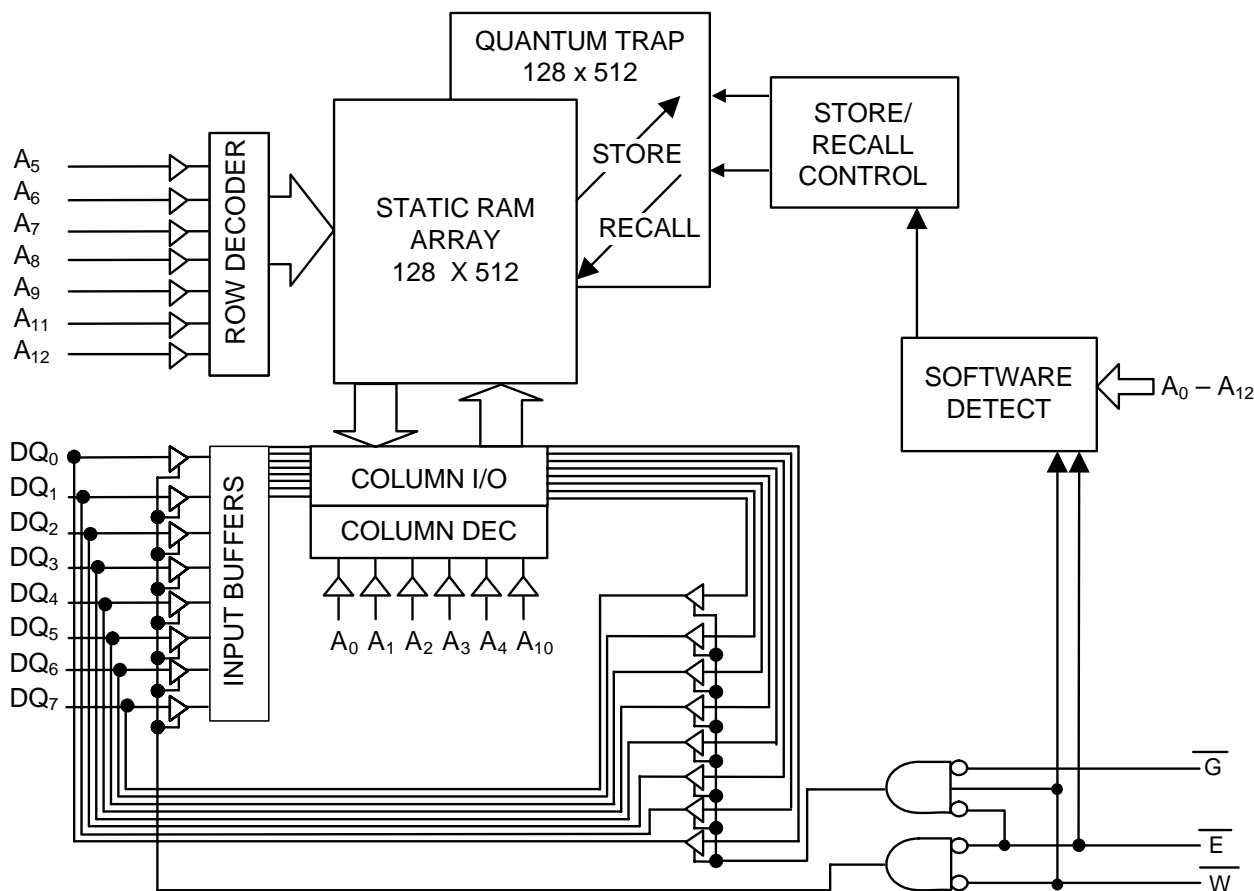

PIN CONFIGURATIONS

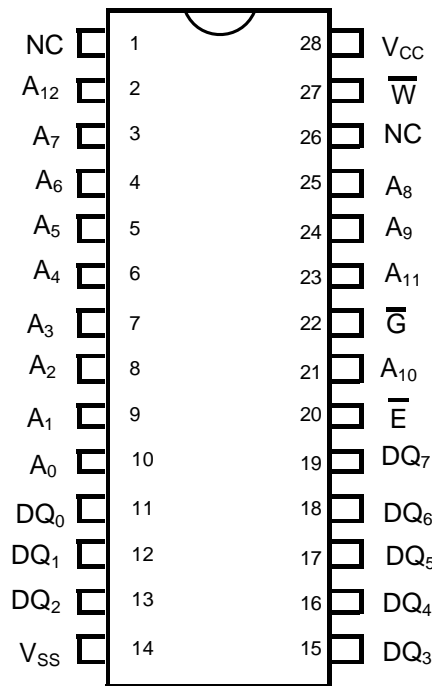

28-Pin DIP

28-Pin SOIC

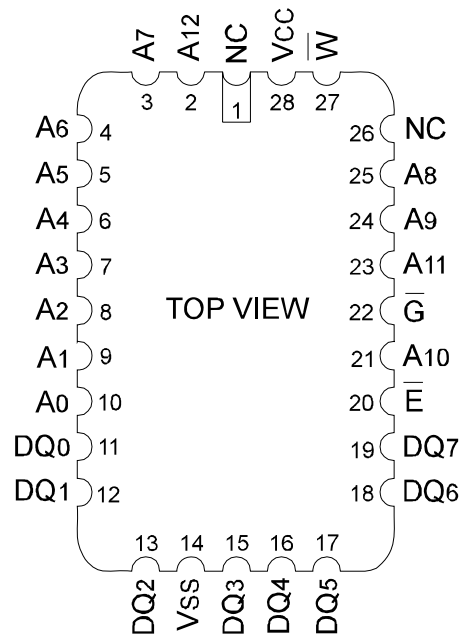

28-Pin LCC

PIN NAMES

Pin Name	I/O	Description
A ₁₂ -A ₀	Input	Address: The 13 address inputs select one of 8,192 bytes in the nvSRAM array
DQ ₇ -DQ ₀	I/O	Data: Bi-directional 8-bit data bus for accessing the nvSRAM
\bar{E}	Input	Chip Enable: The active low \bar{E} input selects the device
\bar{W}	Input	Write Enable: The active low \bar{W} enables data on the DQ pins to be written to the address location latched by the falling edge of \bar{E}
\bar{G}	Input	Output Enable: The active low \bar{G} input enables the data output buffers during read cycles. De-asserting \bar{G} high caused the DQ pins to tri-state.
V _{CC}	Power Supply	Power: 5.0V, ±10%
V _{SS}	Power Supply	Ground

ABSOLUTE MAXIMUM RATINGS^a

Voltage on Input Relative to Ground	-0.5V to 7.0V
Voltage on Input Relative to V _{SS}	-0.6V to (V _{CC} + 0.5V)
Voltage on DQ ₀₋₇	-0.5V to (V _{CC} + 0.5V)
Temperature under Bias	-55°C to 125°C
Storage Temperature	-65°C to 150°C
Power Dissipation	1W
DC Output Current (1 output at a time, 1s duration)	15mA

Note a: Stresses greater than those listed under "Absolute Maximum Ratings" may cause permanent damage to the device. This is a stress rating only, and functional operation of the device at conditions above those indicated in the operational sections of this specification is not implied. Exposure to absolute maximum rating conditions for extended periods may affect reliability.

DC CHARACTERISTICS

(V_{CC} = 5.0V ± 10%)

SYMBOL	PARAMETER	COMMERCIAL		INDUSTRIAL/ MILITARY		UNITS	NOTES
		MIN	MAX	MIN	MAX		
I _{CC1} ^b	Average V _{CC} Current		90 75 65 N/A		90 75 65 55	mA	t _{AVAV} = 25ns t _{AVAV} = 35ns t _{AVAV} = 45ns t _{AVAV} = 55ns
I _{CC2} ^c	Average V _{CC} Current during STORE		3		3	mA	All Inputs Don't Care, V _{CC} = max
I _{CC3} ^b	Average V _{CC} Current at t _{AVAV} = 200ns 5V, 25°C, Typical		10		10	mA	$\bar{W} \geq (V_{CC} - 0.2V)$ All Others Cycling, CMOS Levels
I _{SB1} ^d	Average V _{CC} Current (Standby, Cycling TTL Input Levels)		27 23 20 N/A		28 24 21 20	mA	t _{AVAV} = 25ns, $\bar{E} \geq V_{IH}$ t _{AVAV} = 35ns, $\bar{E} \geq V_{IH}$ t _{AVAV} = 45ns, $\bar{E} \geq V_{IH}$ t _{AVAV} = 55ns, $\bar{E} \geq V_{IH}$
I _{SB2} ^d	V _{CC} Standby Current (Standby, Stable CMOS Input Levels)		750		1500	μA	$\bar{E} \geq (V_{CC} - 0.2V)$ All Others V _{IN} ≤ 0.2V or ≥ (V _{CC} - 0.2V)
I _{ILK}	Input Leakage Current		±1		±1	μA	V _{CC} = max V _{IN} = V _{SS} to V _{CC}
I _{OLK}	Off-State Output Leakage Current		±5		±5	μA	V _{CC} = max V _{IN} = V _{SS} to V _{CC} , \bar{E} or $\bar{G} \geq V_{IH}$
V _{IH}	Input Logic "1" Voltage	2.2	V _{CC} + .5	2.2	V _{CC} + .5	V	All Inputs
V _{IL}	Input Logic "0" Voltage	V _{SS} - .5	0.8	V _{SS} - .5	0.8	V	All Inputs
V _{OH}	Output Logic "1" Voltage	2.4		2.4		V	I _{OUT} = -4mA
V _{OL}	Output Logic "0" Voltage		0.4		0.4	V	I _{OUT} = 8mA
T _A	Operating Temperature	0	70	-40	85	°C	

Note b: I_{CC1} and I_{CC3} are dependent on output loading and cycle rate. The specified values are obtained with outputs unloaded.

Note c: I_{CC2} is the average current required for the duration of the STORE cycle (t_{STORE}).

Note d: $\bar{E} \geq V_{IH}$ will not produce standby current levels until any nonvolatile cycle in progress has timed out.

AC TEST CONDITIONS

Input Pulse Levels	0V to 3V
Input Rise and Fall Times	≤ 5ns
Input and Output Timing Reference Levels	1.5V
Output Load	See Figure 1

CAPACITANCE^e (T_A = 25°C, f = 1.0MHz)

SYMBOL	PARAMETER	MAX	UNITS	CONDITIONS
C _{IN}	Input capacitance	8	pF	ΔV = 0 to 3V
C _{OUT}	Output Capacitance	7	pF	ΔV = 0 to 3V

Note e: These parameters are guaranteed but not tested.

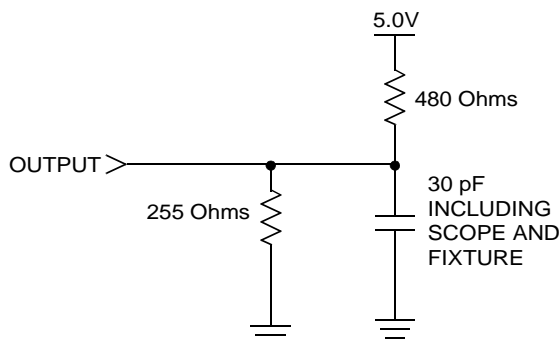

Figure 1: AC Output Loading

SRAM READ CYCLES #1 & #2

($V_{CC} = 5.0V \pm 10\%$)

NO.	SYMBOLS		PARAMETER	STK11C68-25		STK11C68-35		STK11C68-45		STK11C68-55		UNITS
	#1, #2	Alt.		MIN	MAX	MIN	MAX	MIN	MAX	MIN	MAX	
1	t_{ELQV}	t_{ACS}	Chip Enable Access Time		25		35		45		55	ns
2	t_{AVAV}^f	t_{RC}	Read Cycle Time	25		35		45		55		ns
3	t_{AVQV}^g	t_{AA}	Address Access Time		25		35		45		55	ns
4	t_{GLQV}	t_{OE}	Output Enable to Data Valid		10		15		20		25	ns
5	t_{AXQX}^g	t_{OH}	Output Hold after Address Change	5		5		5		5		ns
6	t_{ELQX}	t_{LZ}	Chip Enable to Output Active	5		5		5		5		ns
7	t_{EHQZ}^h	t_{HZ}	Chip Disable to Output Inactive		10		13		15		25	ns
8	t_{GLQX}	t_{OLZ}	Output Enable to Output Active	0		0		0		0		ns
9	t_{GHQZ}^h	t_{OHZ}	Output Disable to Output Inactive		10		13		15		25	ns
10	t_{ELICCH}^e	t_{PA}	Chip Enable to Power Active	0		0		0		0		ns
11	$t_{EHICCL}^{d,e}$	t_{PS}	Chip Disable to Power Standby		25		35		45		55	ns

Note f: \bar{W} must be high during SRAM READ cycles and low during SRAM WRITE cycles.

Note g: I/O state assumes $\bar{E}, \bar{G} < V_{IL}$ and $W > V_{IH}$; device is continuously selected.

Note h: Measured $\pm 200mV$ from steady state output voltage.

SRAM READ CYCLE #1: Address Controlled^{f, g}

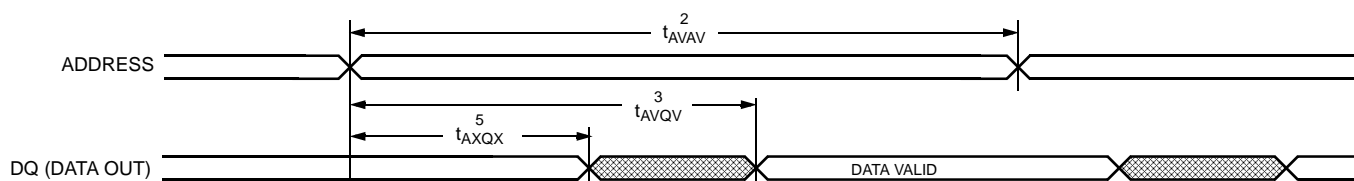

SRAM READ CYCLE #2: \bar{E} Controlled^f

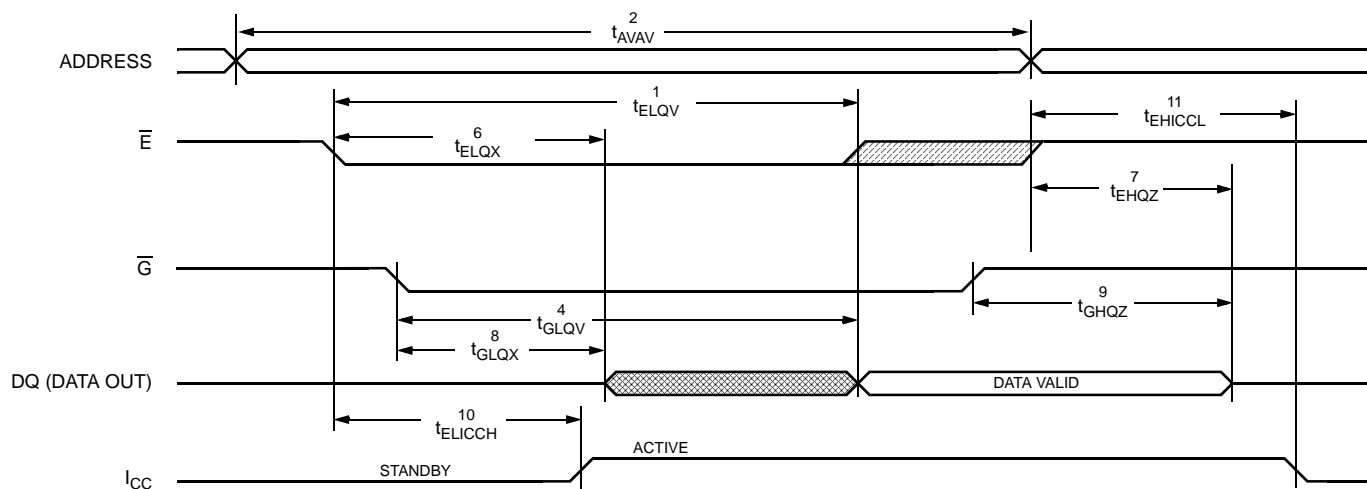

SRAM WRITE CYCLES #1 & #2

($V_{CC} = 5.0V \pm 10\%$)

NO.	SYMBOLS			PARAMETER	STK11C68-25		STK11C68-35		STK11C68-45		STK11C68-55		UNITS
	#1	#2	Alt.		MIN	MAX	MIN	MAX	MIN	MAX	MIN	MAX	
12	t_{AVAV}	t_{AVAV}	t_{WC}	Write Cycle Time	25		35		45		55		ns
13	t_{WLWH}	t_{WLEH}	t_{WP}	Write Pulse Width	20		25		30		45		ns
14	t_{ELWH}	t_{ELEH}	t_{CW}	Chip Enable to End of Write	20		25		30		45		ns
15	t_{DVWH}	t_{DVEH}	t_{DW}	Data Set-up to End of Write	10		12		15		30		ns
16	t_{WHDX}	t_{EHDX}	t_{DH}	Data Hold after End of Write	0		0		0		0		ns
17	t_{AVWH}	t_{AVEH}	t_{AW}	Address Set-up to End of Write	20		25		30		45		ns
18	t_{AVWL}	t_{AVEL}	t_{AS}	Address Set-up to Start of Write	0		0		0		0		ns
19	t_{WHAX}	t_{EHAX}	t_{WR}	Address Hold after End of Write	0		0		0		0		ns
20	$t_{WLQZ}^{h,i}$		t_{WZ}	Write Enable to Output Disable		10		13		15		35	ns
21	t_{WHQX}		t_{OW}	Output Active after End of Write	5		5		5		5		ns

Note i: If \bar{W} is low when \bar{E} goes low, the outputs remain in the high-impedance state.

Note j: \bar{E} or \bar{W} must be $\geq V_{IH}$ during address transitions.

SRAM WRITE CYCLE #1: \bar{W} Controlled^j

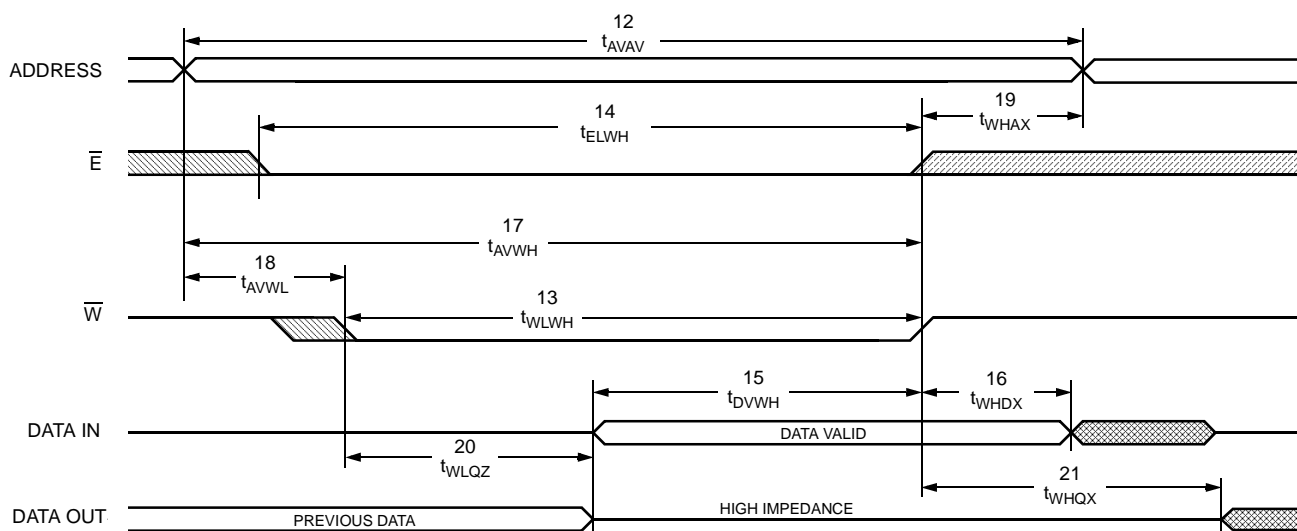

SRAM WRITE CYCLE #2: \bar{E} Controlled^j

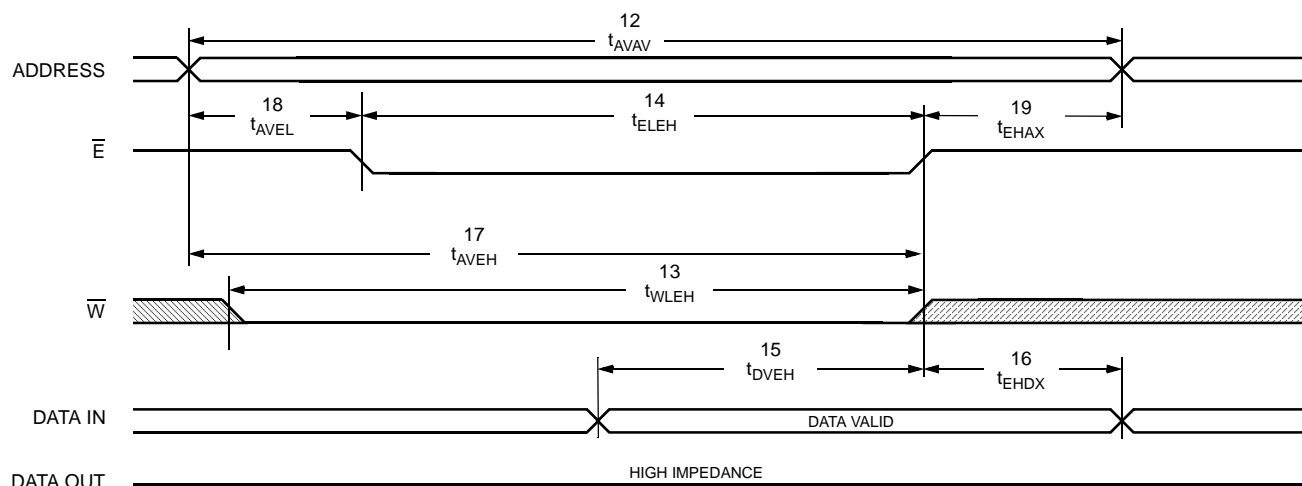

STORE INHIBIT/POWER-UP RECALL

($V_{CC} = 5.0V \pm 10\%$)

NO.	SYMBOLS	PARAMETER	STK11C68		UNITS	NOTES
	Standard		MIN	MAX		
22	$t_{RESTORE}$	Power-up <i>RECALL</i> Duration		550	μs	k
23	t_{STORE}	<i>STORE</i> Cycle Duration		10	ms	
24	V_{SWITCH}	Low Voltage Trigger Level	4.0	4.5	V	
25	V_{RESET}	Low Voltage Reset Level		3.6	V	

Note k: $t_{RESTORE}$ starts from the time V_{CC} rises above V_{SWITCH} .

STORE INHIBIT/POWER-UP RECALL

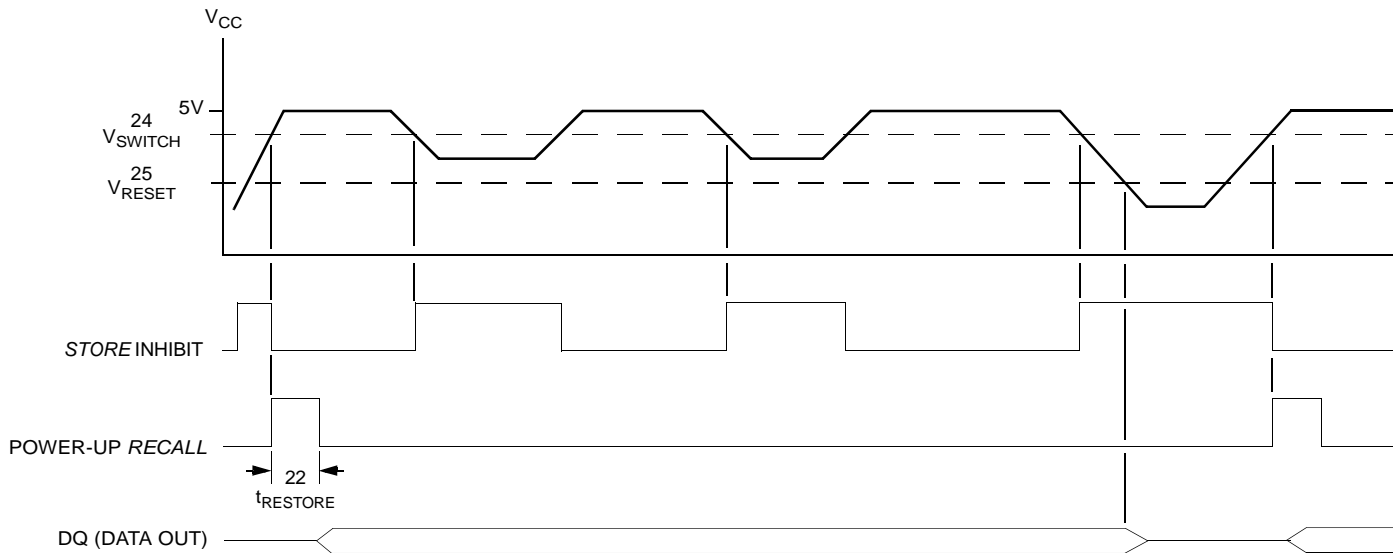

POWER-UP
RECALL

BROWN OUT
STORE INHIBIT
NO *RECALL*
(V_{CC} DID NOT GO
BELOW V_{RESET})

BROWN OUT
STORE INHIBIT
NO *RECALL*
(V_{CC} DID NOT GO
BELOW V_{RESET})

BROWN OUT
STORE INHIBIT
RECALL WHEN
 V_{CC} RETURNS
ABOVE V_{SWITCH}

SOFTWARE STORE/RECALL MODE SELECTION

\bar{E}	\bar{W}	A ₁₂ - A ₀ (hex)	MODE	I/O	NOTES
L	H	0000	Read SRAM	Output Data	I
		1555	Read SRAM	Output Data	
		0AAA	Read SRAM	Output Data	
		1FFF	Read SRAM	Output Data	
		10F0	Read SRAM	Output Data	
		0F0F	Nonvolatile STORE	Output High Z	
L	H	0000	Read SRAM	Output Data	I
		1555	Read SRAM	Output Data	
		0AAA	Read SRAM	Output Data	
		1FFF	Read SRAM	Output Data	
		10F0	Read SRAM	Output Data	
		0F0E	Nonvolatile RECALL	Output High Z	

Note I: The six consecutive addresses must be in the order listed. \bar{W} must be high during all six consecutive cycles to enable a nonvolatile cycle.

SOFTWARE STORE/RECALL CYCLE^{m, n}

(V_{CC} = 5.0V ± 10%)

NO.	SYMBOLS	PARAMETER	STK11C68-25		STK11C68-35		STK11C68-45		STK11C68-55		UNITS
			MIN	MAX	MIN	MAX	MIN	MAX	MIN	MAX	
26	t _{AVAV}	STORE/RECALL Initiation Cycle Time	25		35		45		55		ns
27	t _{AVEL} ^m	Address Set-up Time	0		0		0		0		ns
28	t _{ELEH} ^m	Clock Pulse Width	20		25		30		35		ns
29	t _{ELAX} ^m	Address Hold Time	20		20		20		20		ns
30	t _{RECALL} ^m	RECALL Duration		20		20		20		20	μs

Note m: The software sequence is clocked with \bar{E} controlled reads.

Note n: The six consecutive addresses must be in the order listed in the Software STORE/RECALL Mode Selection Table: (0000, 1555, 0AAA, 1FFF, 10F0, 0F0F) for a STORE cycle or (0000, 1555, 0AAA, 1FFF, 10F0, 0F0E) for a RECALL cycle. \bar{W} must be high during all six consecutive cycles.

SOFTWARE STORE/RECALL CYCLE: \bar{E} Controlledⁿ

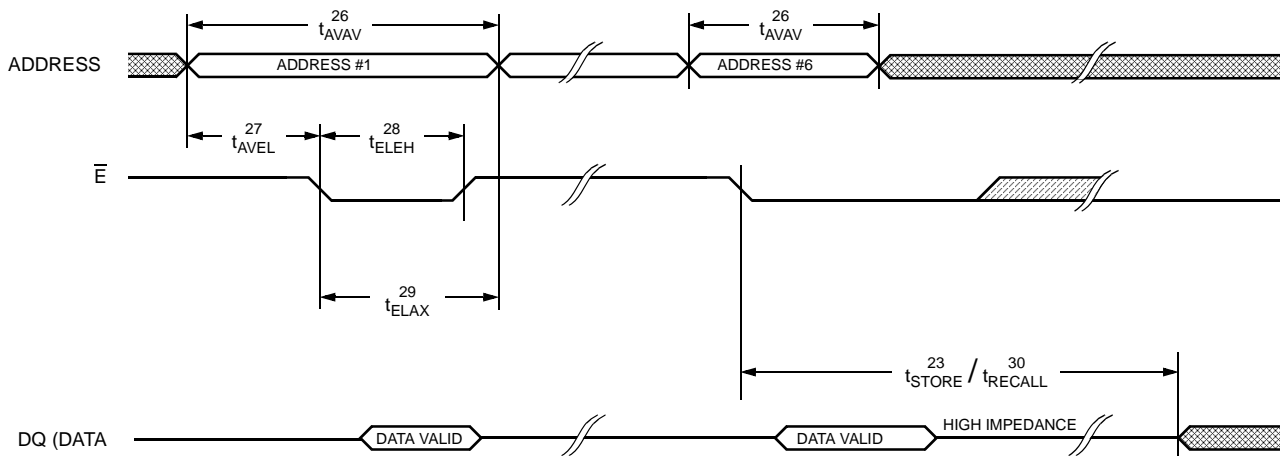

DEVICE OPERATION

The STK11C68 is a versatile memory chip that provides several modes of operation. The STK11C68 can operate as a standard 8K x 8 SRAM. It has an 8K x 8 Nonvolatile Elements shadow to which the SRAM information can be copied or from which the SRAM can be updated in nonvolatile mode.

NOISE CONSIDERATIONS

Note that the STK11C68 is a high-speed memory and so must have a high-frequency bypass capacitor of approximately 0.1µF connected between V_{CC} and V_{SS} , using leads and traces that are as short as possible. As with all high-speed CMOS ICs, normal careful routing of power, ground and signals will help prevent noise problems.

SRAM READ

The STK11C68 performs a READ cycle whenever \overline{E} and \overline{G} are low and \overline{W} is high. The address specified on pins A_{0-12} determines which of the 8,192 data bytes will be accessed. When the READ is initiated by an address transition, the outputs will be valid after a delay of t_{AVQV} (READ cycle #1). If the READ is initiated by \overline{E} or \overline{G} , the outputs will be valid at t_{ELQV} or at t_{GLQV} , whichever is later (READ cycle #2). The data outputs will repeatedly respond to address changes within the t_{AVQV} access time without the need for transitions on any control input pins, and will remain valid until another address change or until \overline{E} or \overline{G} is brought high.

SRAM WRITE

A WRITE cycle is performed whenever \overline{E} and \overline{W} are low. The address inputs must be stable prior to entering the WRITE cycle and must remain stable until either \overline{E} or \overline{W} goes high at the end of the cycle. The data on the common I/O pins DQ_{0-7} will be written into the memory if it is valid t_{DVWH} before the end of a \overline{W} controlled WRITE or t_{DVEH} before the end of an \overline{E} controlled WRITE.

It is recommended that \overline{G} be kept high during the entire WRITE cycle to avoid data bus contention on the common I/O lines. If \overline{G} is left low, internal circuitry will turn off the output buffers t_{WLQZ} after \overline{W} goes low.

SOFTWARE NONVOLATILE STORE

The STK11C68 software STORE cycle is initiated by executing sequential READ cycles from six specific address locations. During the STORE cycle an erase of the previous nonvolatile data is first performed, followed by a program of the nonvolatile elements. The program operation copies the SRAM data into nonvolatile memory. Once a STORE cycle is initiated, further input and output are disabled until the cycle is completed.

Because a sequence of READs from specific addresses is used for STORE initiation, it is important that no other READ or WRITE accesses intervene in the sequence or the sequence will be aborted and no STORE or RECALL will take place.

To initiate the software STORE cycle, the following READ sequence must be performed:

1. Read address	0000 (hex)	Valid READ
2. Read address	1555 (hex)	Valid READ
3. Read address	0AAA (hex)	Valid READ
4. Read address	1FFF (hex)	Valid READ
5. Read address	10F0 (hex)	Valid READ
6. Read address	0F0F (hex)	Initiate STORE cycle

The software sequence must be clocked with \overline{E} controlled READs.

Once the sixth address in the sequence has been entered, the STORE cycle will commence and the chip will be disabled. It is important that READ cycles and not WRITE cycles be used in the sequence, although it is not necessary that \overline{G} be low for the sequence to be valid. After the t_{STORE} cycle time has been fulfilled, the SRAM will again be activated for READ and WRITE operation.

SOFTWARE NONVOLATILE RECALL

A software RECALL cycle is initiated with a sequence of READ operations in a manner similar to the software STORE initiation. To initiate the RECALL cycle, the following sequence of READ operations must be performed:

1. Read address	0000 (hex)	Valid READ
2. Read address	1555 (hex)	Valid READ
3. Read address	0AAA (hex)	Valid READ
4. Read address	1FFF (hex)	Valid READ
5. Read address	10F0 (hex)	Valid READ
6. Read address	0F0E (hex)	Initiate RECALL cycle

Internally, *RECALL* is a two-step procedure. First, the SRAM data is cleared, and second, the nonvolatile information is transferred into the SRAM cells. After the t_{RECALL} cycle time the SRAM will once again be ready for READ and WRITE operations. The *RECALL* operation in no way alters the data in the Nonvolatile Elements. The nonvolatile data can be recalled an unlimited number of times.

POWER-UP RECALL

During power up, or after any low-power condition ($V_{CC} < V_{RESET}$), an internal *RECALL* request will be latched. When V_{CC} once again exceeds the sense voltage of V_{SWITCH} , a *RECALL* cycle will automatically be initiated and will take $t_{RESTORE}$ to complete.

If the STK11C68 is in a WRITE state at the end of power-up *RECALL*, the SRAM data will be corrupted. To help avoid this situation, a 10K Ohm resistor should be connected either between \overline{W} and system V_{CC} or between \overline{E} and system V_{CC} .

HARDWARE PROTECT

The STK11C68 offers hardware protection against inadvertent *STORE* operation during low-voltage conditions. When $V_{CC} < V_{SWITCH}$, software *STORE* operations are inhibited.

LOW AVERAGE ACTIVE POWER

The STK11C68 draws significantly less current when it is cycled at times longer than 50ns. Figure 2 shows the relationship between I_{CC} and READ cycle time. Worst-case current consumption is shown for both CMOS and TTL input levels (commercial temperature range, $V_{CC} = 5.5V$, 100% duty cycle on chip enable). Figure 3 shows the same relationship for WRITE cycles. If the chip enable duty cycle is less than 100%, only standby current is drawn when the chip is disabled. The overall average current drawn by the STK11C68 depends on the following items: 1) CMOS vs. TTL input levels; 2) the duty cycle of chip enable; 3) the overall cycle rate for accesses; 4) the ratio of READs to WRITEs; 5) the operating temperature; 6) the V_{CC} level; and 7) I/O loading.

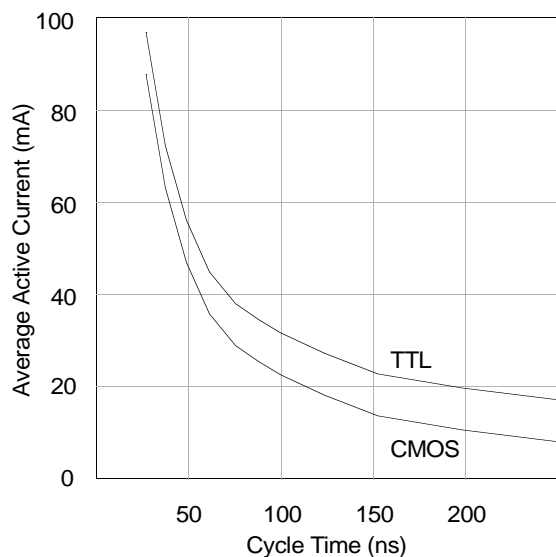

Figure 2: I_{CC} (max) Reads

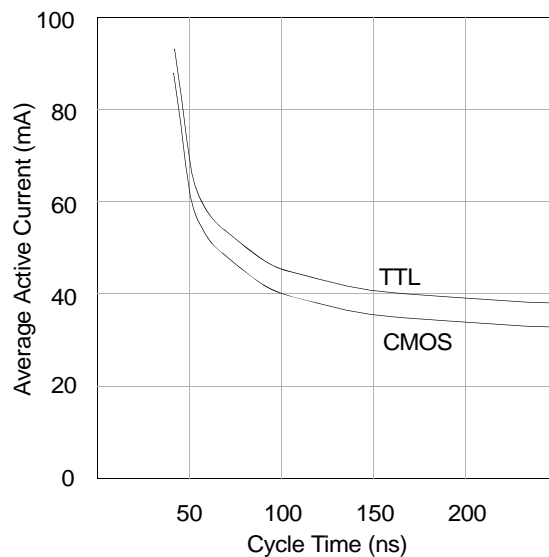
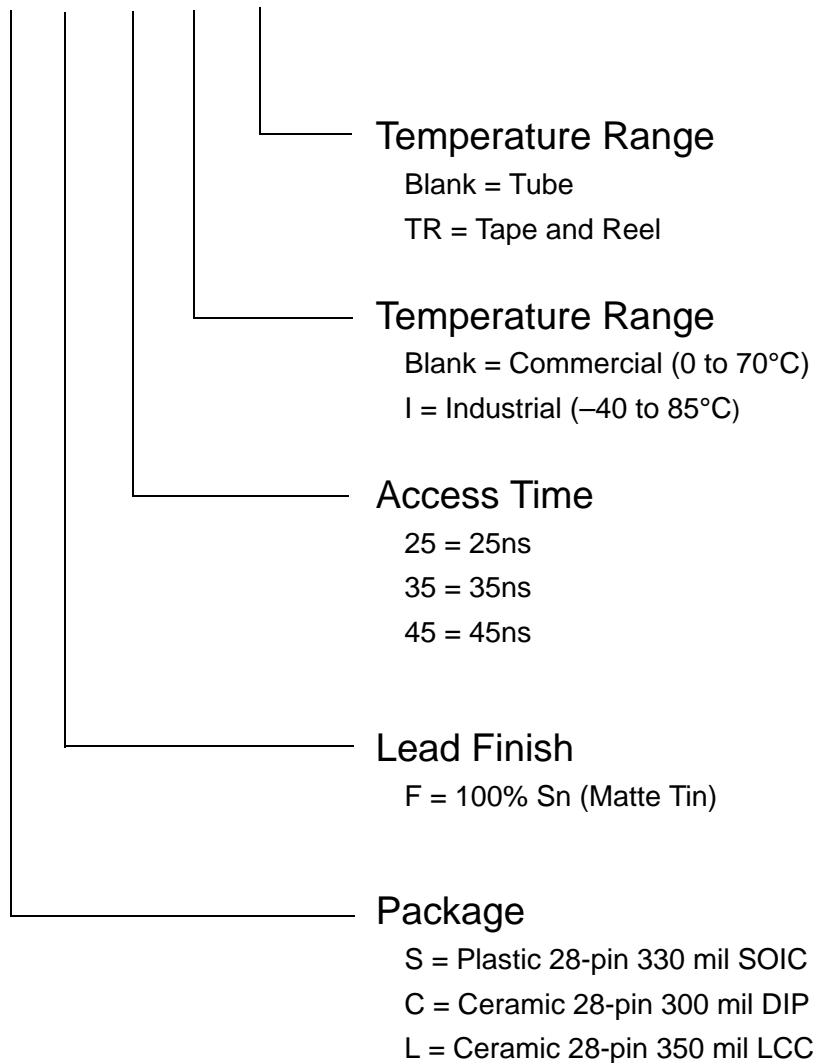

Figure 3: I_{CC} (max) Writes

Commercial/Industrial Ordering Information

STK11C68 - S F 45 I TR



Military Ordering Information

STK11C68 - 5 C 45 M

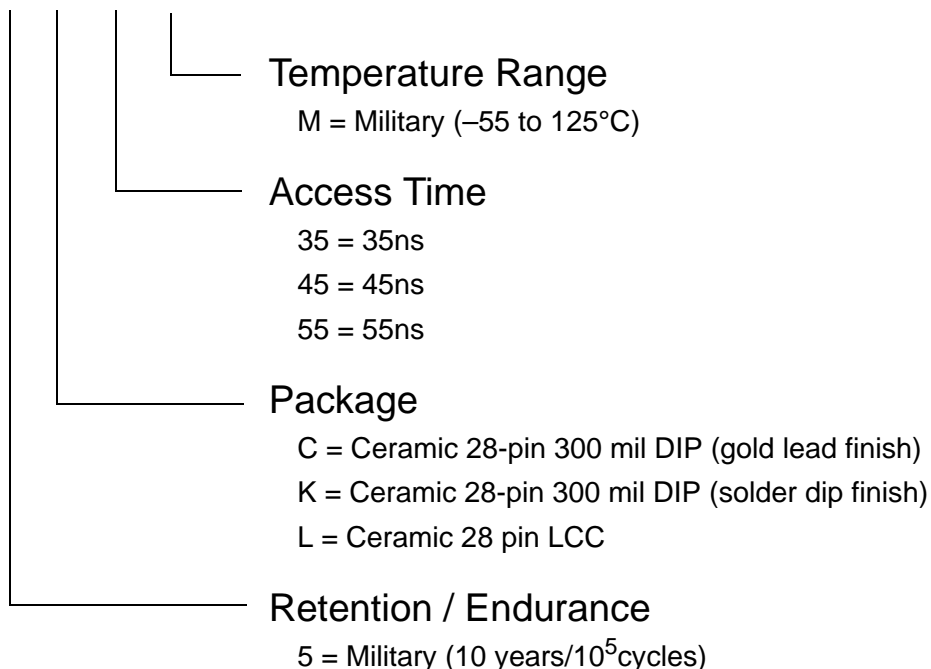

SMD5962-92324 04 MX X

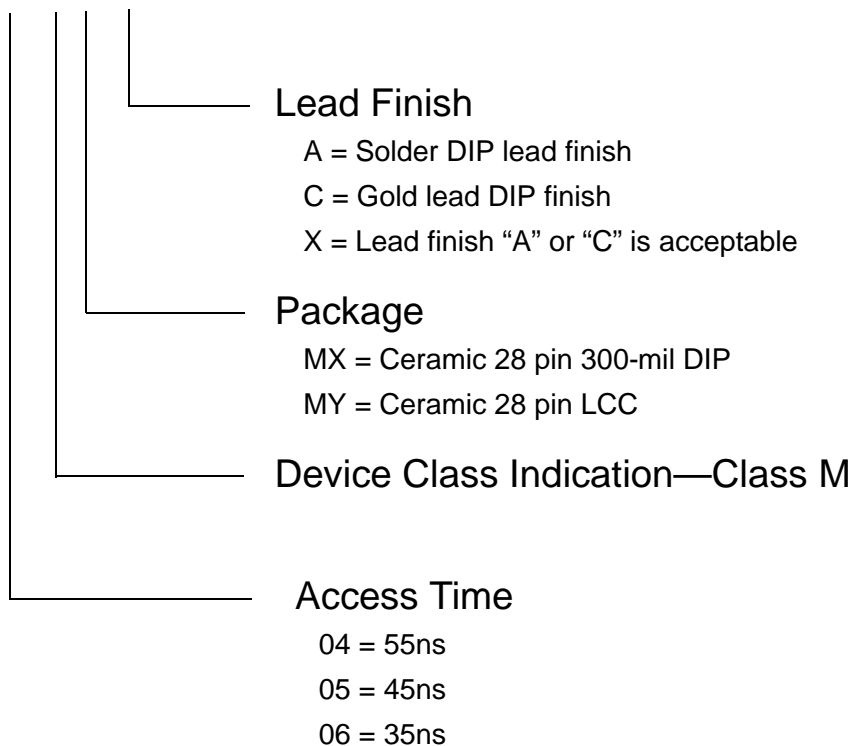

Ordering Information

Part Number	Description	Temperature
STK11C68-SF25	5V 64K-8b SoftStore nvSRAM SOP28-330	Commercial
STK11C68-SF35	5V 64K-8b SoftStore nvSRAM SOP28-330	Commercial
STK11C68-SF45	5V 64K-8b SoftStore nvSRAM SOP28-330	Commercial
STK11C68-SF25TR	5V 64K-8b SoftStore nvSRAM SOP28-330	Commercial
STK11C68-SF35TR	5V 64K-8b SoftStore nvSRAM SOP28-330	Commercial
STK11C68-SF45TR	5V 64K-8b SoftStore nvSRAM SOP28-330	Commercial
STK11C68-L35	5V 64K-8b SoftStore nvSRAM CLCC28	Commercial
STK11C68-L45	5V 64K-8b SoftStore nvSRAM CLCC28	Commercial
STK11C68-C35	5V 64K-8b SoftStore nvSRAM CDIP28-300	Commercial
STK11C68-C45	5V 64K-8b SoftStore nvSRAM CDIP28-300	Commercial
STK11C68-SF25I	5V 64K-8b SoftStore nvSRAM SOP28-330	Industrial
STK11C68-SF35I	5V 64K-8b SoftStore nvSRAM SOP28-330	Industrial
STK11C68-SF45I	5V 64K-8b SoftStore nvSRAM SOP28-330	Industrial
STK11C68-SF25ITR	5V 64K-8b SoftStore nvSRAM SOP28-330	Industrial
STK11C68-SF35ITR	5V 64K-8b SoftStore nvSRAM SOP28-330	Industrial
STK11C68-SF45ITR	5V 64K-8b SoftStore nvSRAM SOP28-330	Industrial
STK11C68-L35I	5V 64K-8b SoftStore nvSRAM CLCC28	Industrial
STK11C68-L45I	5V 64K-8b SoftStore nvSRAM CLCC28	Industrial
STK11C68-C35I	5V 64K-8b SoftStore nvSRAM CDIP28-300	Industrial
STK11C68-C45I	5V 64K-8b SoftStore nvSRAM CDIP28-300	Industrial
STK11C68-5L35M	5V 64K-8b SoftStore nvSRAM CLCC28	Military
STK11C68-5L45M	5V 64K-8b SoftStore nvSRAM CLCC28	Military
STK11C68-5L55M	5V 64K-8b SoftStore nvSRAM CLCC28	Military
STK11C68-5C35M	5V 64K-8b SoftStore nvSRAM CDIP28-300	Military
STK11C68-5C45M	5V 64K-8b SoftStore nvSRAM CDIP28-300	Military
STK11C68-5C55M	5V 64K-8b SoftStore nvSRAM CDIP28-300	Military
STK11C68-5K35M	5V 64K-8b SoftStore nvSRAM CDIP28-300	Military
STK11C68-5K45M	5V 64K-8b SoftStore nvSRAM CDIP28-300	Military
STK11C68-5K55M	5V 64K-8b SoftStore nvSRAM CDIP28-300	Military
SMD5962-9232406MXA	5V 64K-8b SoftStore nvSRAM CDIP28-300	Military
SMD 5962-9232405MXA	5V 64K-8b SoftStore nvSRAM CDIP28-300	Military
SMD 5962-9232404MXA	5V 64K-8b SoftStore nvSRAM CDIP28-300	Military
SMD 5962-9232406MXC	5V 64K-8b SoftStore nvSRAM CDIP28-300	Military
SMD 5962-9232405MXC	5V 64K-8b SoftStore nvSRAM CDIP28-300	Military
SMD 5962-9232404MXC	5V 64K-8b SoftStore nvSRAM CDIP28-300	Military
SMD 5962-9232406MXX	5V 64K-8b SoftStore nvSRAM CDIP28-300	Military
SMD 5962-9232405MXX	5V 64K-8b SoftStore nvSRAM CDIP28-300	Military
SMD 5962-9232404MXX	5V 64K-8b SoftStore nvSRAM CDIP28-300	Military
SMD 5962-9232406MYA	5V 64K-8b SoftStore nvSRAM CLCC28	Military
SMD 5962-9232405MYA	5V 64K-8b SoftStore nvSRAM CLCC28	Military
SMD 5962-9232404MYA	5V 64K-8b SoftStore nvSRAM CLCC28	Military
SMD 5962-9232406MYX	5V 64K-8b SoftStore nvSRAM CLCC28	Military
SMD 5962-9232405MYX	5V 64K-8b SoftStore nvSRAM CLCC28	Military
SMD 5962-9232404MYX	5V 64K-8b SoftStore nvSRAM CLCC28	Military

Package Diagrams

28 Pin 330 mil SOIC

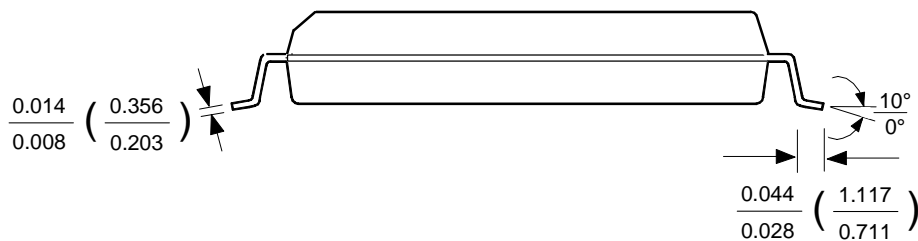
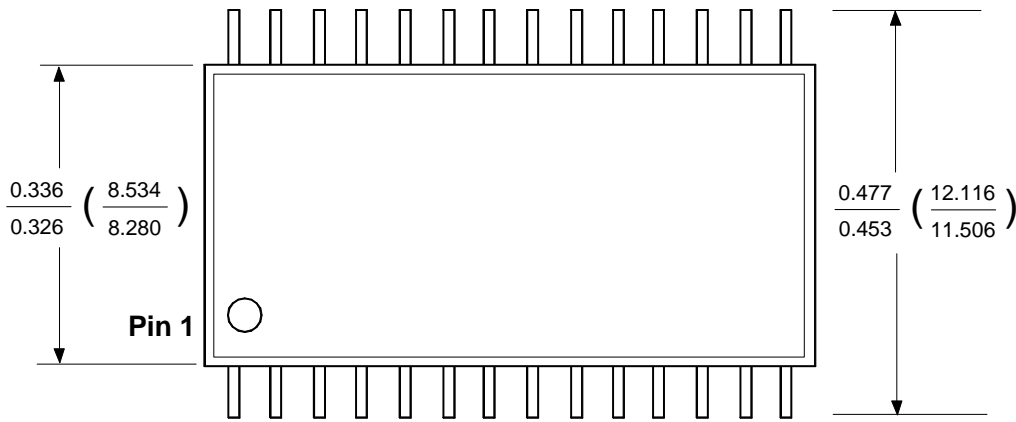
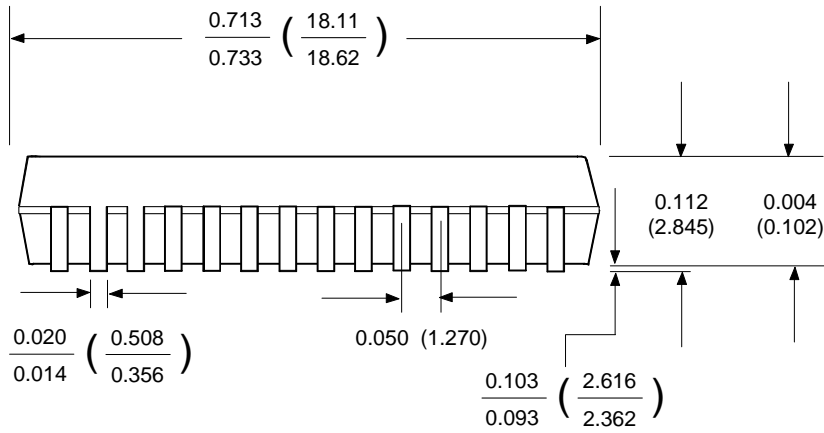

DIM = INCHES $\frac{\text{MIN}}{\text{MAX}}$

DIM = mm ($\frac{\text{MIN}}{\text{MAX}}$)

STK11C68 (SMD5962-92324)

28 Pin 300 mil SP DIL Sidebrazed

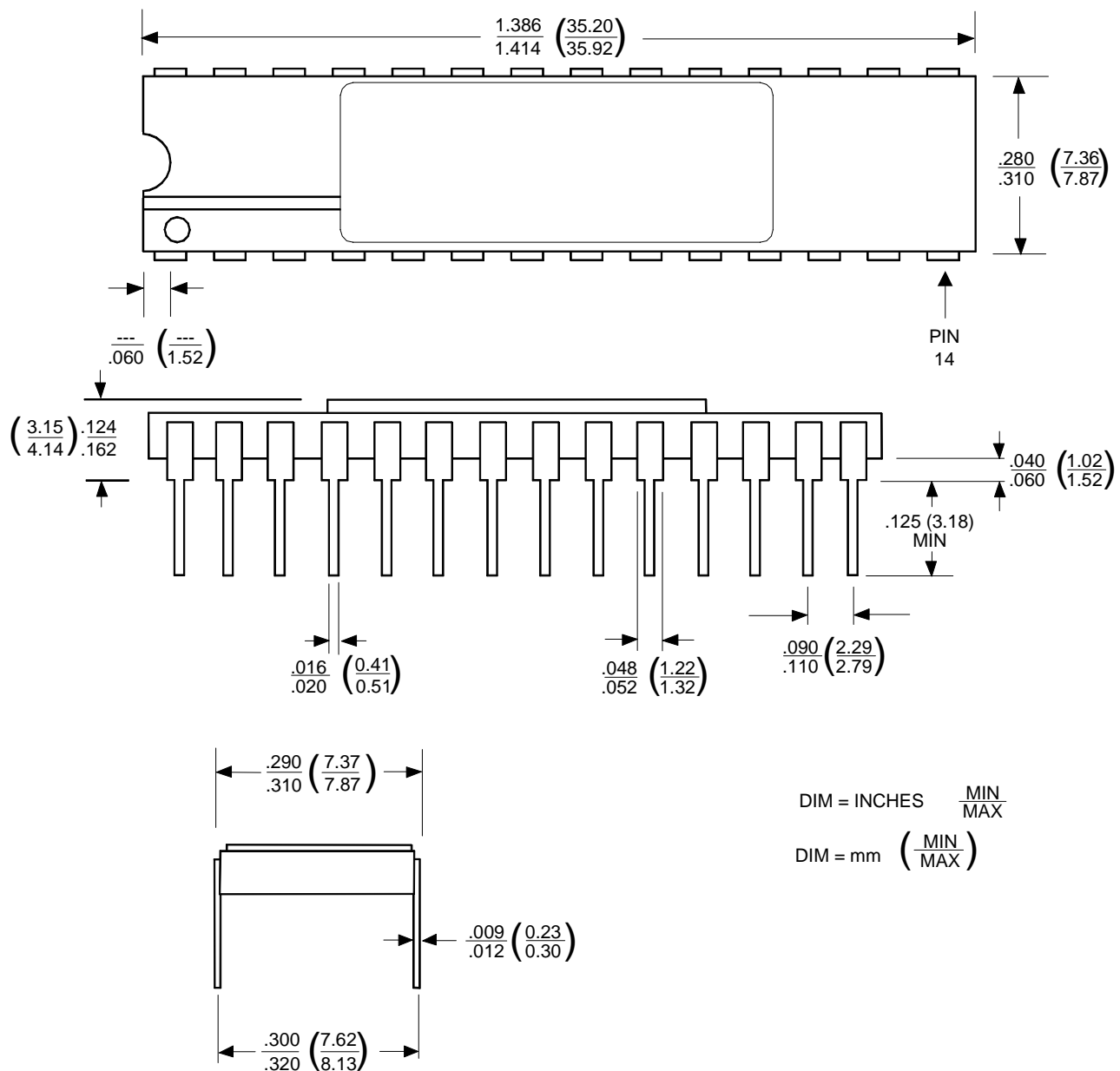

28 Pin 350 mil LCC

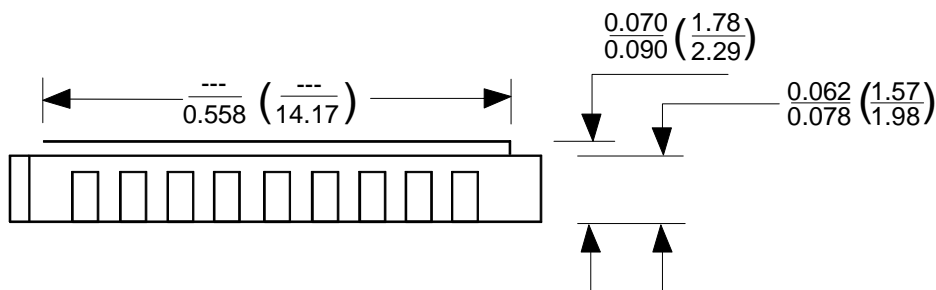
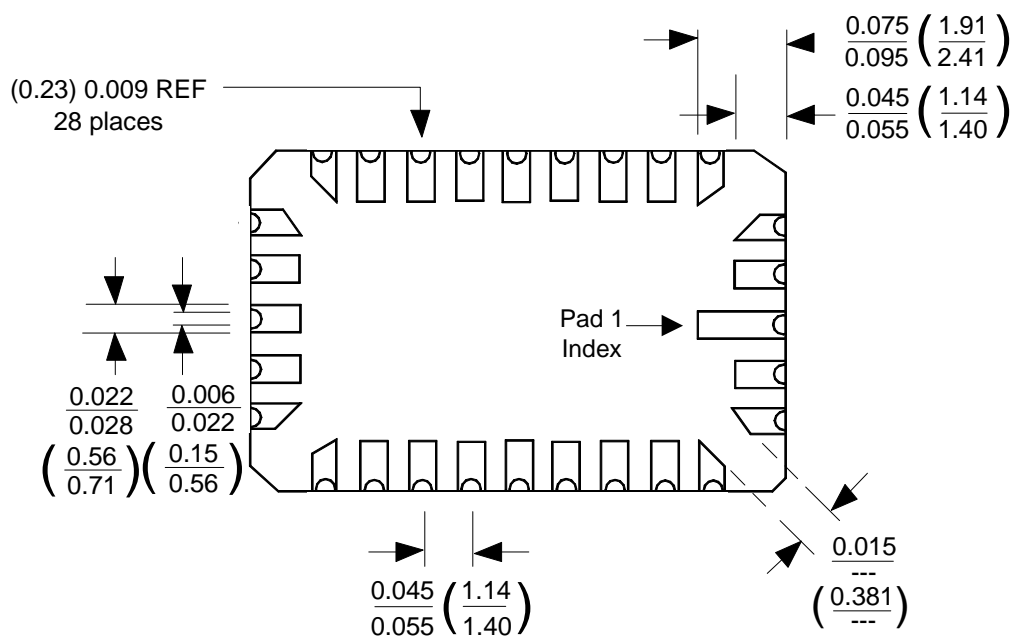
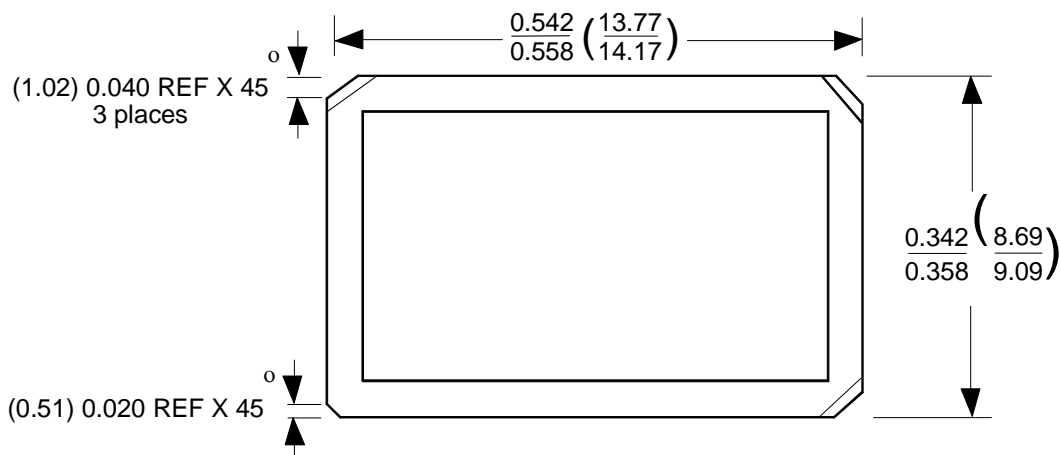

DIM = INCHES $\frac{\text{MIN}}{\text{MAX}}$
 DIM = mm $\left(\frac{\text{MIN}}{\text{MAX}}\right)$

Document Revision History

Revision	Date	Summary
0.0	December 2002	Combined commercial, industrial and military data sheets. Removed 20 nsec device.
0.1	September 2003	Added lead-free lead finish
0.2	March 2006	Removed leaded lead finish for all Commercial/Industrial Parts, Removed "P" package.
0.3	February 2007	Add fast power-down slew RSK information Restore Comm/Ind C & L Package Options Add Tape Reel Ordering Options Add Product Ordering Code Listing Add Package Outline Drawings Reformat Entire Document

SIMTEK STK11C68 Datasheet, February 2007

Copyright 2007, Simtek Corporation. All rights reserved.

This datasheet may only be printed for the expressed use of Simtek Customers. No part of the datasheet may be reproduced in any other form or means without the express written permission from Simtek Corporation. The information contained in this publication is believed to be accurate, but changes may be made without notice. Simtek does not assume responsibility for, or grant or imply any warranty, including MERCHANTABILITY or FITNESS FOR A PARTICULAR PURPOSE regarding this information, the product or its use. Nothing herein constitutes a license, grant or transfer of any rights to any Simtek patent, copyright, trademark, or other proprietary right.