

Nine-Channel DC/DC Digitally Programmable System Power Manager
FEATURES & APPLICATIONS

- Digital programming of all major parameters via I²C interface and non-volatile memory
 - Output voltage set point
 - Output power-up/down sequencing
 - Digital soft-start and output slew rate
 - Input/battery voltage monitoring
 - Dynamic Voltage Management
 - UV/OV monitoring of all outputs
 - Enable/disable outputs independently
- Nine output channels
 - Four synchronous step-down (buck) channels
 - Three step-up (boost) channels
 - One inverting (buck-boost) channel
 - One 3.3V fixed LDO channel
- User friendly Graphical User Interface (GUI)
- 2.7V to 6.0V Input Range
- Highly accurate reference and output voltage (<0.5%) with Active DC Output Control (ADOC™) technology
- Undervoltage Lockout (UVLO) with hysteresis
- 800 kHz operating frequency (trimmable)
- 96 bytes of user configurable nonvolatile memory
- Eight Phase PWM with Phase Locked Loop (PLL)
- 100% Maximum Duty Cycle for Buck channels
- 0% Duty Cycle option for boost and buck-boost channels

Applications

- Digital camcorders/still cameras
- Portable DVD/MP3/GPS
- Camera phones
- TFT/LCD Displays/Monitors/TV's
- Mobile Computing
- Consumer battery-operated equipment
- Intel X-Scale™-based consumer devices

SIMPLIFIED APPLICATIONS DRAWING

Figure 1 – Applications schematic featuring the SMB120 Nine-Channel DC-DC Digitally Programmable Power Manager. This DC/DC controller provides power-on/off control, sequencing, fault monitoring, and Dynamic Voltage Management. Note: This is an applications example only. Some pins, components and values are not shown.

INTRODUCTION

The SMB120 is a highly integrated and flexible nine-channel programmable power manager designed for use in a wide range of portable applications. The built-in digital programmability allows system designers to custom tailor the device to suit almost any multi-channel power supply application from digital camcorders to mobile phones. Complete with a user friendly GUI, all programmable settings including output voltages and input/output voltage monitoring can be customized with ease.

The SMB120 integrates all the essential blocks required to implement a complete nine-channel power subsystem including four synchronous step-down “buck” controllers, three step-up “boost” controllers, one inverting “buck-boost” controller, and one linear regulator (LDO). Additionally sophisticated power control/monitoring functions required by complex systems are built-in. These include digitally programmable output voltage set point, power-up/down sequencing, enable/disable, dynamic voltage management and UV/OV/input monitoring on all channels.

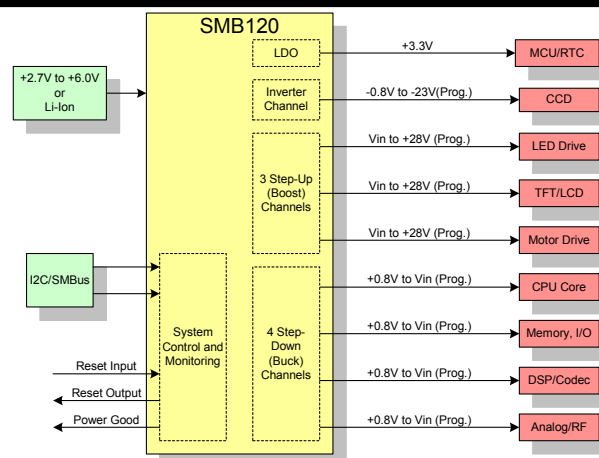
The integration of features and built-in flexibility of the SMB120 allows the system designer to create a “platform solution” that can be easily modified via software without major hardware changes. Combined with the re-programmability of the SMB120 this facilitates rapid design cycles and proliferation from a base design to future generations of product.

The SMB120 is suited to battery-powered applications with an input range of 2.7V to 6.0V. Output voltages are extremely accurate (<0.5%) employing proprietary ADOC™ technology. Communication is via the industry standard I²C bus. All user-programmed settings are stored in non-volatile EEPROM of which 96 bytes may be used for general-purpose memory applications. The commercial operating temperature range is 0°C to +70°C and the industrial temperature range is –40°C to +85°C The SMB120 is available in a lead-free, RoHS compliant 9mm x 9mm 64 pin QFN package.