



rev D

## General Purpose EMI Reduction IC

### Features

- FCC approved method of EMI attenuation
- Provides up to 15 dB of EMI suppression
- Generates a **1 X** or **½ X** low EMI spread spectrum clock of the input frequency
- Output frequency from **6MHz to 20MHz**
- Digital spread selections
- Spreading ranges from +/-0.4% to +/-5.0%
- Ultra low cycle-to-cycle jitter
- Zero-cycle slip
- 3.3V and 5.0V operating voltage range
- 10 mA output drives
- TTL or CMOS compatible outputs
- Ultra-low power CMOS design
- Available in 8 pin SOIC and TSSOP

### Product Description

The P2681A is a versatile spread spectrum frequency modulator designed specifically for digital camera and other digital video and imaging applications. The P2681A reduces electromagnetic interference (EMI) at the clock source, which provides system wide reduction of EMI of all clock dependent signals. The P2681A allows significant

system cost savings by reducing the number of circuit board layers and shielding that are traditionally required to pass EMI regulations.

The P2681A uses the most efficient and optimized modulation profile approved by the FCC.

The P2681A modulates the output of a single PLL in order to “spread” the bandwidth of a synthesized clock and, more importantly, decreases the peak amplitudes of its harmonics. This results in significantly lower system EMI compared to the typical narrow band signal produced by oscillators and most frequency generators. Lowering EMI by increasing a signal’s bandwidth is called “spread spectrum clock generation”.

### Applications

The P2681A is targeted towards MFP, xDSL, fax modem, set-top box, USB controller, DSC, and embedded systems.

### Block Diagram

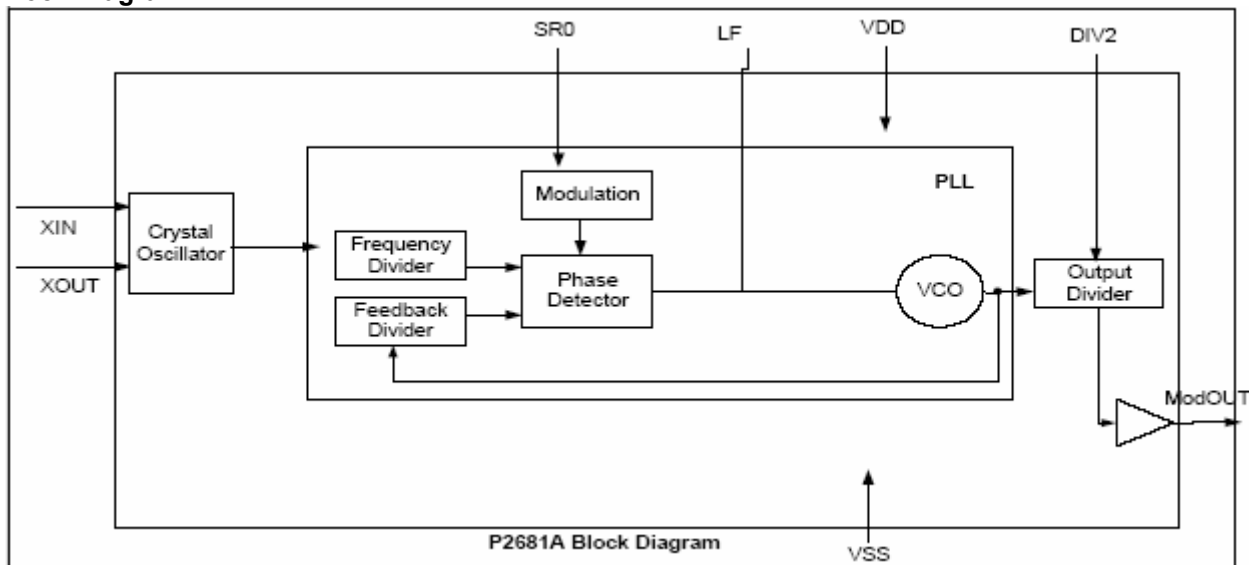

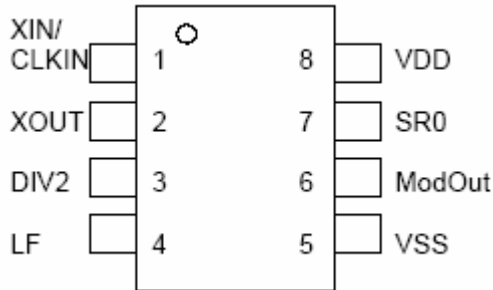

rev D

**Pin Configuration****Pin Description**

Pin#	Pin Name	Type	Description
1	XIN/CLKIN	I	Connect to crystal or clock input.
2	XOUT	I	Crystal output
3	DIV2	I	Digital logic input used to select normal output mode or divide-by-2 output mode. When this pin is Low, the frequency of the output clock is the same as the input clock frequency. When it is tied High, the output frequency is half the input clock frequency. This pin has an internal pull-low resistor.
4	LF	I	External Loop Filter for the PLL. By changing the value of the CRC circuit, the % spread can be adjusted accordingly. See Table 1.2 for detail value.
5	VSS	I	Ground Connection. Connect to system ground.
6	ModOUT	O	Spread Spectrum Clock Output.
7	SR0	I	Digital logic input used to select Spreading Range between large or small for a given LF value (see Table 1.1 and 1.2). When SR0=0, the spreading % is smaller than SR0=1. This pin has an internal pull-up resistor.
8	VDD	P	Connect to +3.3V or 5.0V



rev D

Table 1 - Modulation Output and Spreading Selection VDD @ 3.3V

DIV=0	Xin	6 MHz	8 MHz	10 MHz	12 MHz	16 MHz	Modulation Rate
	ModOut	6 MHz	8 MHz	10 MHz	12 MHz	16 MHz	
SR0	0	TBD	TBD	+/-0.75%	+/-0.75%	+/-0.75%	ModOut/256
	1	TBD	TBD	+/-1.30%	+/-1.30%	+/-1.30%	ModOut/256
Loop filter value*		TBD	TBD	C1=1,000 pF C2=10,000 pF R1=1K	C1=1,000 pF C2=10,000 pF R1=1.5K	C1=390 pF C2=3,900 pF R1=2.2K	

DIV=0	Xin	6 MHz	8 MHz	10 MHz	12 MHz	16 MHz	Modulation Rate
	ModOut	3 MHz	4 MHz	5 MHz	6 MHz	8 MHz	
SR0	0	TBD	TBD	+/-0.75%	+/-0.75%	+/-0.75%	ModOut/128
	1	TBD	TBD	+/-1.30%	+/-1.30%	+/-1.30%	ModOut/128
Loop filter value*		TBD	TBD	C1=1,000 pF C2=10,000 pF R1=1K	C1=1,000 pF C2=10,000 pF R1=1.5K	C1=390 pF C2=3,900 pF R1=2.2K	

\*For additional spread % selection please refer to Loop Filter Selection Table

Table 2 - Loop Filter Selection Table VDD @ 3.3V

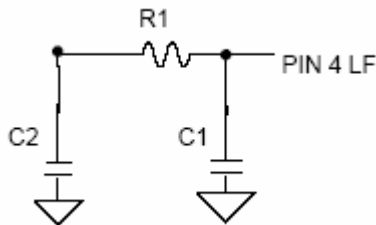

Please contact Alliance Semiconductor for more information



rev D

**Spread Spectrum Selection**

The P2681A performs Zero Cycle Slip when sets at low % spreading. This allows no occurrence of system timing error. The optimal setting should minimize system EMI to the fullest without affecting system performance. The spreading is described as a percentage deviation of the center frequency (Note: the center frequency is the frequency of the external reference input on CLKIN, Pin 1).

**Example:** The P2681A is designed for PC peripheral applications. It is not only optimized for operation between 6MHz – 16MHz range, but its output frequency can be extended down to one half of the input clock frequency using the Divide-by-Two feature. This feature extends low frequency operation to as low as 3MHz. Setting Pin 3 high (**DIV2=1**; Divide-by-Two mode) sets the output frequency (**ModOUT**) to half the frequency of the input clock (**CLKIN**). This is a simple way to generate a spread spectrum modulated low frequency clock when only a higher frequency signal is available. If you want the output frequency to be the same as the input, you need to set **DIV2=0**.

The P2681A's spread % selection is determined by the external LF value specified in Table 2. Table 1 provides a particular LF value which allows the % spreading to be selected between +/-0.75% or +/-1.30% by setting SR0 to either 0 and 1. At a specified LF value (See Table 2), SR0 pin allows the user to have the flexibility to digitally select between large or small % spreading by setting SR0=1 or SR0=0 respectively.

**P2681A Application Schematic**

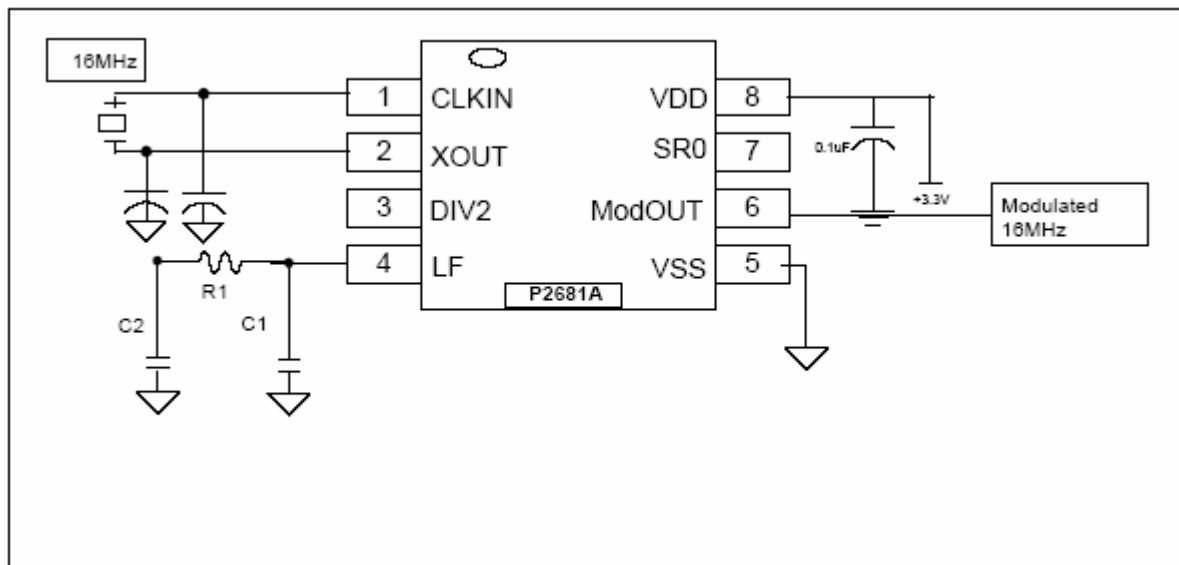



rev D

### EMC Software Simulation

By using Alliance Semiconductor's proprietary EMC simulation software – EMI-lator®, radiated system level EMI analysis can be made easier to allow a quantitative assessment on Alliance's EMI reduction products. The simulation engine of this EMC software has already been characterized to correlate with the electrical characteristics of Alliance EMI reduction IC's. The figure below is an example of the simulation result. Please visit our web site at [www.alsc.com](http://www.alsc.com) for information on how to obtain a free copy and demonstration of EMI-lator®.

### Simulation Result from EMI-lator®

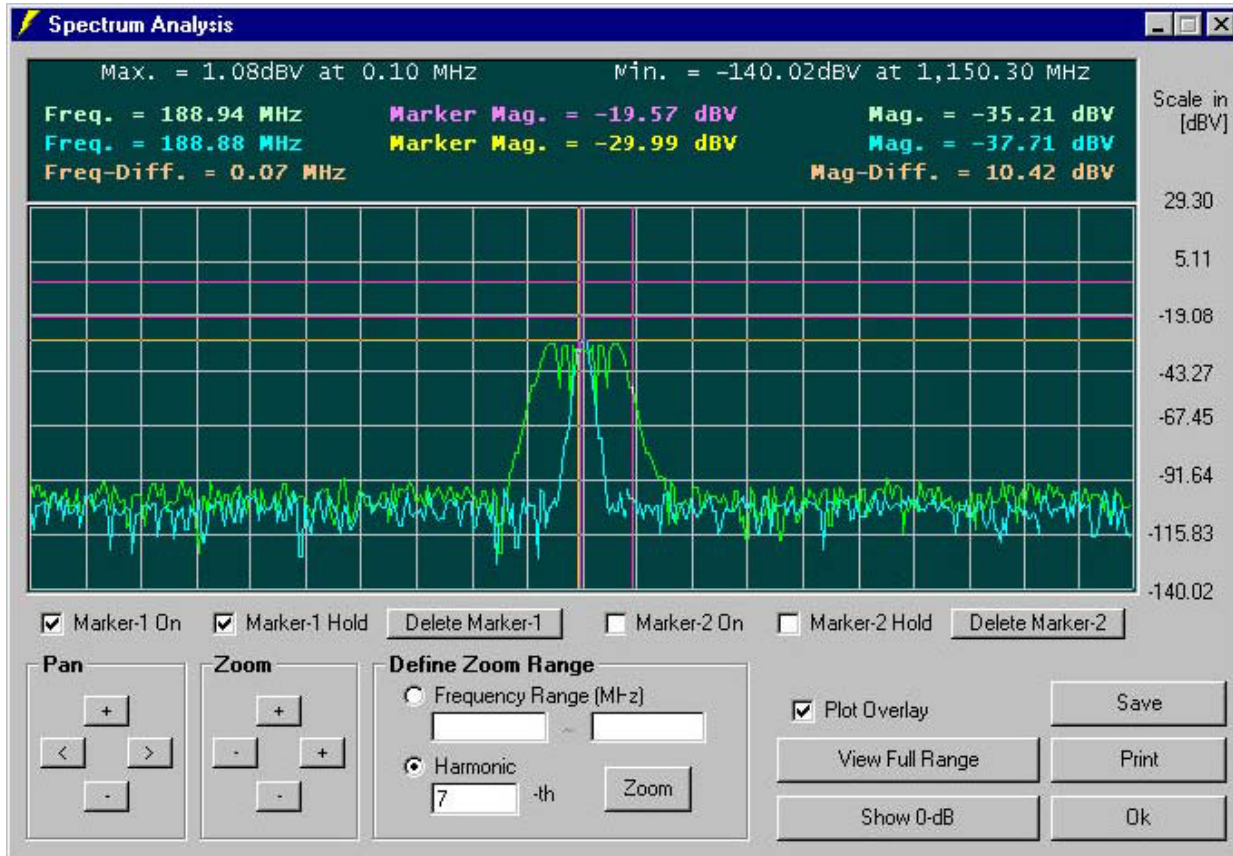



## rev D

## Absolute Maximum Ratings

Symbol	Parameter	Rating	Unit
$V_{DD}, V_{IN}$	Voltage on any pin with respect to GND	-0.5 to + 7.0	V
$T_{STG}$	Storage temperature	-65 to +125	°C
$T_A$	Operating temperature	0 to +70	°C

## DC Electrical Characteristics

Symbol	Parameter	Min	Typ	Max	Unit
$V_{IL}$	Input Low Voltage	GND – 0.3	-	0.8	V
$V_{IH}$	Input High Voltage	2.0	-	$V_{DD} + 0.3$	V
$I_{IL}$	Input Low Current (internal input pull-up resistor on DIV2 and SR0)	-	TBD	-	$\mu$ A
$I_{IH}$	Input High Current (internal input pull-up resistor on DIV2 and SR0)	-	TBD	-	$\mu$ A
$I_{XOL}$	XOUT Output Low Current (@ 0.4V, $V_{DD} = 3.3V$ )	-	TBD	-	mA
$I_{XOH}$	XOUT Output High Current (@ 2.5V, $V_{DD} = 3.3V$ )	-	TBD	-	mA
$V_{OL}$	Output Low Voltage ( $V_{DD} = 3.3V$ , $I_{OL} = 20$ mA)	-	-	0.4	V
$V_{OH}$	Output High Voltage ( $V_{DD} = 3.3V$ , $I_{OH} = 20$ mA)	2.5	-	-	V
$I_{DD}$	Static Supply Current	-	TBD	-	mA
$I_{CC}$	Dynamic Supply Current (3.3V and 10 pF loading)	3 Xin=6MHz	TBD	15 Xin=20MHz	mA
$V_{DD}$	Operating Voltage	TBD	3.3	TBD	V

## AC Electrical Characteristics

Symbol	Parameter	Min	Typ	Max	Unit
$f_{IN}$	Input Frequency when	6	-	20	MHz
$t_{LH}^*$	Output rise time (Measured at 0.8V to 2.0V)		TBD		ns
$t_{HL}^*$	Output fall time (Measured at 0.8V to 2.0V)		TBD		ns
$t_{JC}$	Jitter (cycle to cycle)	-	-	TBD	ps
$t_D$	Output duty cycle	45	50	55	%

\* $t_{LH}$  and  $t_{HL}$  are measured into a capacitive load of 15pF



rev D

Package Information

Mechanical Package Outline 8-Pin SOIC

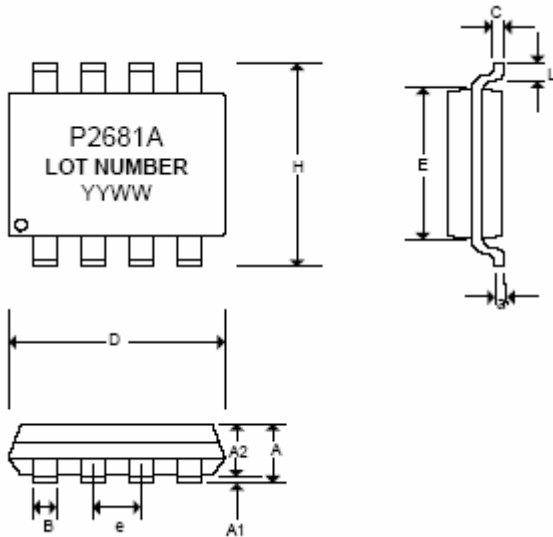

Symbol	Dimensions in inches			Dimensions in millimeters		
	Min	Nor	Max	Min	Nor	Max
A	0.057	0.064	0.071	1.45	1.63	1.80
A1	0.004	0.007	0.010	0.10	0.18	0.25
A2	0.053	0.061	0.069	1.35	1.55	1.75
B	0.012	0.016	0.020	0.31	0.41	0.51
C	0.004	0.006	0.01	0.10	0.15	0.25
D	0.186	0.194	0.202	4.72	4.92	5.12
E	0.148	0.156	0.164	3.75	3.95	4.15
e	0.050 BSC			1.27 BSC		
H	0.224	0.236	0.248	5.70	6.00	6.30
L	0.012	0.020	0.028	0.30	0.50	0.70
a	0°	5°	8°	0°	5°	8°

Note: Controlling dimensions are millimeters



rev D

**Mechanical Package Outline 8-Pin TSSOP**

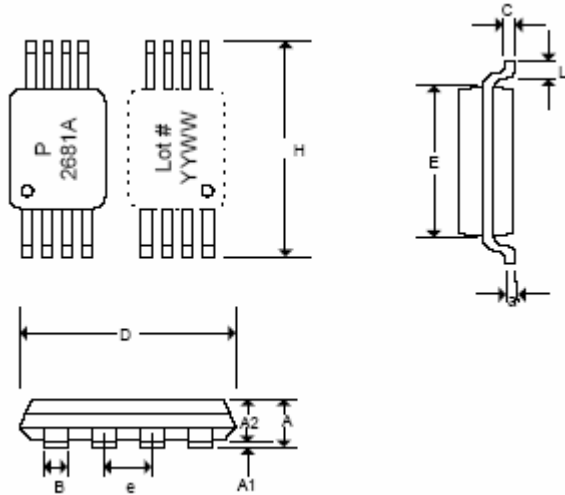

Symbol	Dimensions in inches			Dimensions in millimeters		
	Min	Nor	Max	Min	Nor	Max
A			0.047			1.10
A1	0.002		0.006	0.05		0.15
A2	0.031	0.039	0.041	0.80	1.00	1.05
B	0.007		0.012	0.19		0.30
C	0.004		0.008	0.09		0.20
D	0.114	0.118	0.122	2.90	3.00	3.10
E	0.169	0.173	0.177	4.30	4.40	4.50
e	0.026 BSC			0.65 BSC		
H	0.244	0.252	0.260	6.20	6.40	6.60
L	0.018	0.024	0.030	0.45	0.60	0.75
a	0°	5°	8°	0°	5°	8°

Note: Controlling dimensions are millimeters





rev D

## Ordering Codes

Part Number	Marking	Package Type	Qty per reel	Temperature (°C)
P2681A-08ST	P2681A	8-pin SOIC, tube		0 to 70
P2681A-08SR	P2681A	8-pin SOIC, tape & reel	2500	0 to 70
P2681A-08TT	P2681A	8-pin TSSOP, tube		0 to 70
P2681A-08TR	P2681A	8-pin TSSOP, tape & reel	2500	0 to 70

Licensed under US patent Nos 5,488,627 and 5,631,920.  
Preliminary datasheet. Specification subject to change without notice.



rev D



Alliance Semiconductor Corporation  
2595, Augustine Drive,  
Santa Clara, CA 95054  
Tel# 408-855-4900  
Fax: 408-855-4999  
www.alsc.com

Copyright © Alliance Semiconductor  
All Rights Reserved  
Part Number: P2681A  
Document Version: D

© Copyright 2003 Alliance Semiconductor Corporation. All rights reserved. Our three-point logo, our name and Intelliwatt are trademarks or registered trademarks of Alliance. All other brand and product names may be the trademarks of their respective companies. Alliance reserves the right to make changes to this document and its products at any time without notice. Alliance assumes no responsibility for any errors that may appear in this document. The data contained herein represents Alliance's best data and/or estimates at the time of issuance. Alliance reserves the right to change or correct this data at any time, without notice. If the product described herein is under development, significant changes to these specifications are possible. The information in this product data sheet is intended to be general descriptive information for potential customers and users, and is not intended to operate as, or provide, any guarantee or warranty to any user or customer. Alliance does not assume any responsibility or liability arising out of the application or use of any product described herein, and disclaims any express or implied warranties related to the sale and/or use of Alliance products including liability or warranties related to fitness for a particular purpose, merchantability, or infringement of any intellectual property rights, except as express agreed to in Alliance's Terms and Conditions of Sale (which are available from Alliance). All sales of Alliance products are made exclusively according to Alliance's Terms and Conditions of Sale. The purchase of products from Alliance does not convey a license under any patent rights, copyrights; mask works rights, trademarks, or any other intellectual property rights of Alliance or third parties. Alliance does not authorize its products for use as critical components in life-supporting systems where a malfunction or failure may reasonably be expected to result in significant injury to the user, and the inclusion of Alliance products in such life-supporting systems implies that the manufacturer assumes all risk of such use and agrees to indemnify Alliance against all claims arising from such use.