

Features

1. Uni-directional data transmission using plastic fiber
2. Signal transmission speed
:MAX. 13.2 Mbps (NRZ signal)
3. Operating voltage :4.75 to 5.25 V
4. TTL compatible
5. Suitable for MOF-T3C4 Transmitter

Outline Dimensions

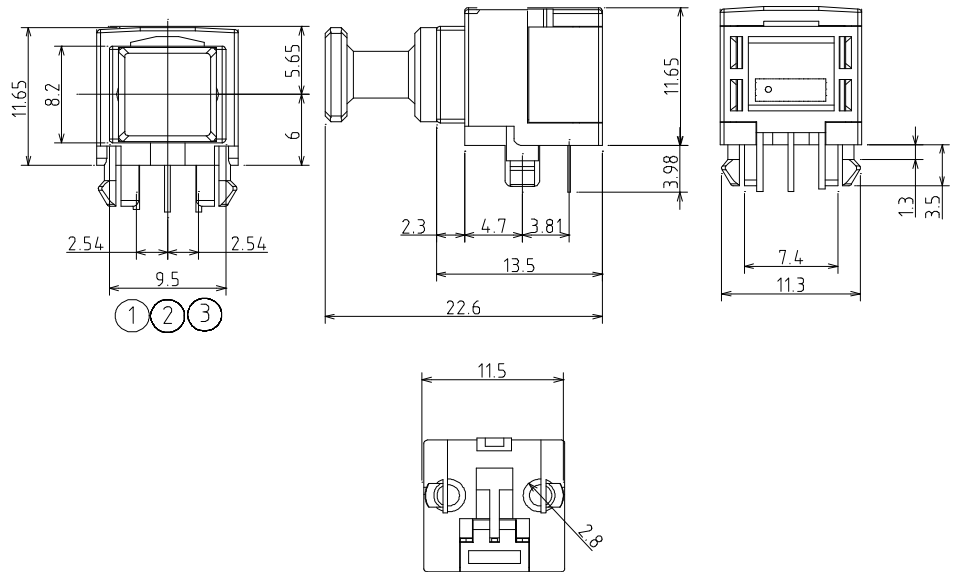

Recommended drilling as viewed from the soldering face

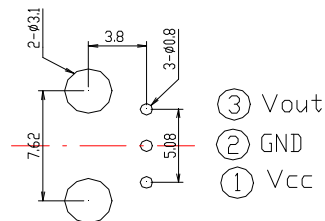

NOTES:

Tolerance is $\pm 0.3\text{mm}$ unless otherwise noted.

Absolute Maximum Ratings

@ $T_A = 25^\circ\text{C}$

Parameter	Symbol	Rating	Unit
Supply voltage	V_{cc}	-0.5 to +6	V
High Level Output Current	I_{OH}	-1	mA
Low Level Output Current	I_{OL}	5	mA
Operating temperature	T_{opr}	-20 to +70	$^\circ\text{C}$
Storage temperature	T_{stg}	-30 to +80	$^\circ\text{C}$
Soldering Temperature	T_{SOL}	260*	$^\circ\text{C}$

* For 5s (1 times or less)

Recommended Operating Conditions

Parameter	Symbol	MIN.	TYP.	MAX.	Unit
Operating supply voltage	V_{cc}	4.75	5.0	5.25	V
Operating transfer rate	T	0.1	---	13.2	Mbps
receiver input optical power level	P_c	-24	---	-14.5	dBm

Recommended Connection Method

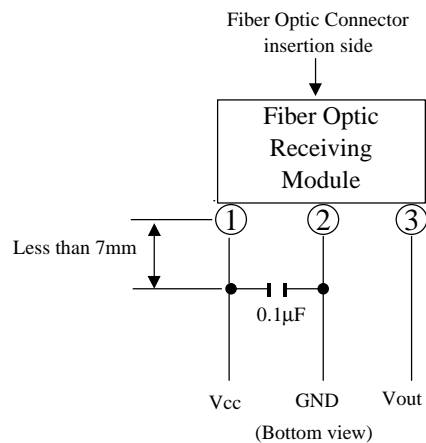

Electro-Optical Characteristics

Parameter	Symbol	Conditions	MIN.	TYP.	MAX.	Unit
Dissipation current	I_{cc}	Refer to Fig. 1	---	15	40	mA
High level output voltage	V_{OH}	Refer to Fig. 2	2.4	4.8	---	V
Low level output voltage	V_{OL}	Refer to Fig. 2	---	0.2	0.4	V
Rise time	t_r	Refer to Fig. 2	---	10	20	ns
Fall time	t_f	Refer to Fig. 2	---	10	20	ns
Low High delay time	t_{pLH}	Refer to Fig. 2	---	100	180	ns
High Low delay time	t_{pHL}	Refer to Fig. 2	---	100	180	ns
Pulse width distortion	Δ_{tw}	Refer to Fig. 2	-15	---	+15	ns

Fig. 1 Measuring Method of Supply Current.

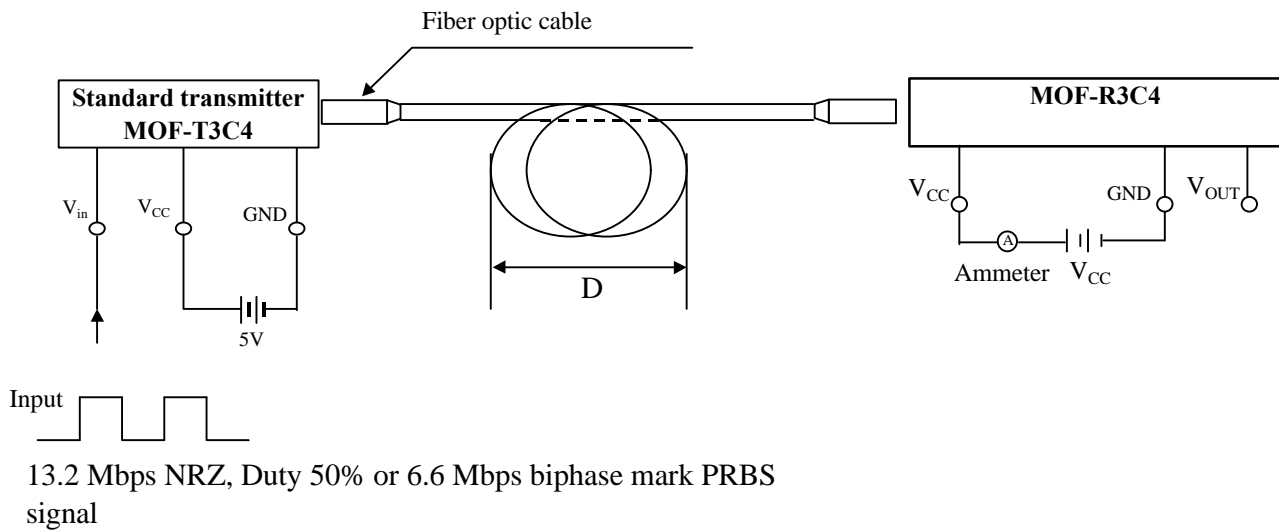

Notes (1) $V_{cc}=5.0V$ (State of operating)

(2) To bundle up the standard fiber optic cable, make it into a loop with the diameter $D=10cm$ or more.

(3) $P_c = -14.5 \text{ dBm}$

(4) Measured on an ammeter.

Fig. 2 Measuring Method of Output Voltage and Pulse Response

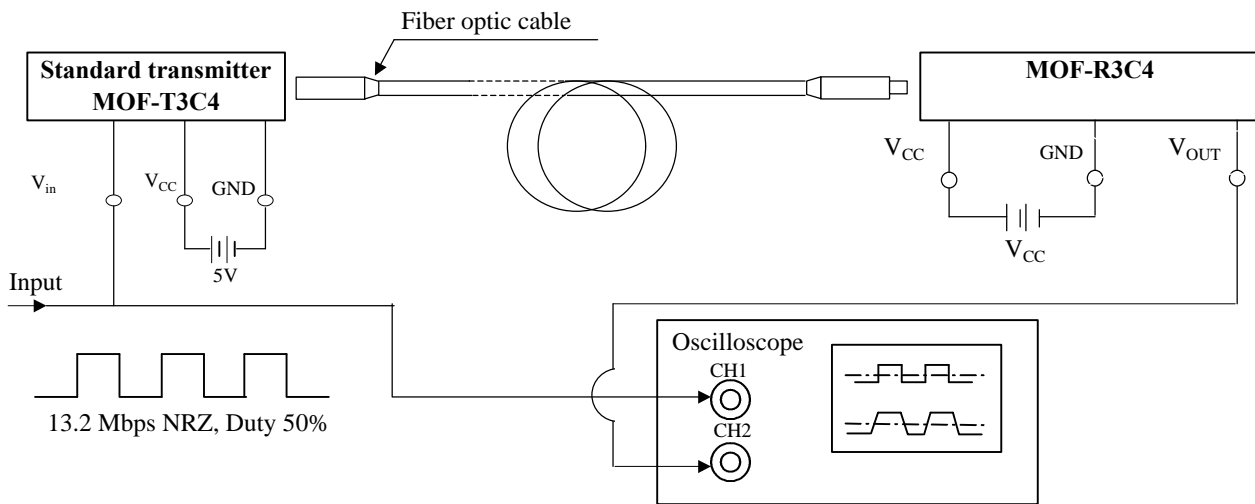

Test item

Test item	Symbol
Low High pulse delay time	t_{PLH}
High Low pulse delay time	t_{PHL}
Rise time	t_r
Fall time	t_f
Pulse width distortion $tw = t_{PHL} - t_{PLH}$	tw
High level output voltage	V_{OH}
Low level output voltage	V_{OL}

