

16-bit Proprietary Microcontroller

CMOS

F²MC-16LX MB90460 Series

MB90462/467/F462/V460

■ DESCRIPTION

The MB90460 series is a line of general-purpose, Fujitsu 16-bit microcontrollers designed for process control applications which require high-speed real-time processing, such as consumer products.

While inheriting the AT architecture of the F²MC^{*} family, the instruction set for the F²MC-16LX CPU core of the MB90460 series incorporates additional instructions for high-level languages, supports extended addressing modes, and contains enhanced multiplication and division instructions as well as a substantial collection of improved bit manipulation instructions. In addition, the MB90460 has an on-chip 32-bit accumulator which enables processing of long-word data.

The peripheral resources integrated in the MB90460 series include : an 8/10-bit A/D converter, UARTs (SCI) 0 to 1, 16-bit PPG timer, a multi-functional timer (16-bit free-run timer, input capture units (ICUs) 0 to 3, output compare units (OCUs) 0 and 5, 16-bit PPG timer, a waveform generator) , a multi-pulse generator (16-bit PPG timer, 16-bit reload timer, waveform sequencer) , PWC 0 to 1, 16-bit reload timer and DTP/external interrupt.

* : F²MC stands for FUJITSU Flexible Microcontroller, a registered trademark of FUJITSU LIMITED.

■ FEATURES

- Minimum execution time : 62.5 ns/4 MHz oscillation (Uses PLL clock multiplication) maximum multiplier = 4
- Maximum memory space
16 Mbyte
Linear/bank access

(Continued)

■ PACKAGES

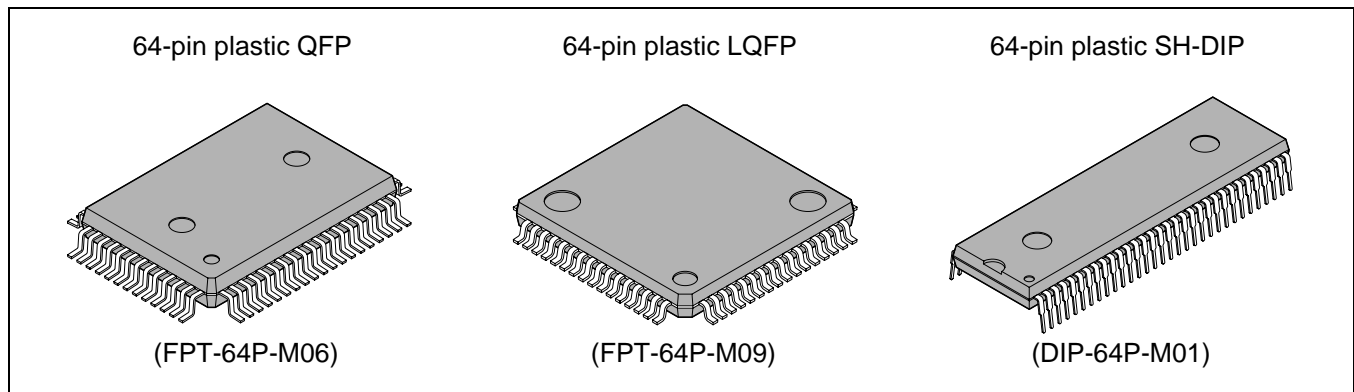

MB90460 Series

(Continued)

- Instruction set optimized for controller applications
 - Supported data types : bit, byte, word, and long-word types
 - Standard addressing modes : 23 types
 - 32-bit accumulator enhancing high-precision operations
 - Signed multiplication/division and extended RETI instructions
- Enhanced high level language (C) and multi-tasking support instructions
 - Use of a system stack pointer
 - Symmetrical instruction set and barrel shift instructions
- Program patch function (for two address pointers)
- Enhanced execution speed : 4 byte instruction queue
- Enhanced interrupt function
 - Up to eight programmable priority levels
 - External interrupt inputs : 8 lines
- Automatic data transmission function independent of CPU operation
 - Up to 16 channels for the extended intelligent I/O service
 - DTP request inputs : 8 lines
- Internal ROM
 - FLASH : 64 Kbyte (with flash security)
 - MASKROM : 64 Kbyte
- Internal RAM
 - EVA : 8 Kbyte
 - FLASH : 2 Kbyte
 - MASKROM : 2 Kbyte
- General-purpose ports
 - Up to 51 channels (Input pull-up resistor settable for : 16 channels)
- A/D Converter (RC) : 8 ch
 - 8/10-bit resolution selectable
 - Conversion time : 6.13 μ s (Min) , 16 MHz operation
- UART : 2 channels
- 16 bit PPG : 3 channels
 - Mode switching function provided (PWM mode or one-shot mode)
 - Can be worked with a multi-functional timer, a multi-pulse generator or individually
- 16 bit reload timer : 2 channels
 - Can be worked with multi-pulse generator or individually
- 16-bit PWC timer : 2 channels
- A multi-functional timer
 - Input capture : 4 channels
 - Output compare with selectable buffer : 6 channels
 - Free-run timer with up or up/down mode selection and selectable buffer : 1 channel
 - 16-bit PPG : 1 channel
 - A waveform generator : (16-bit timer : 3 channels, 3-phase waveform or dead time)
- A multi-pulse generator
 - 16-bit PPG : 1 channel
 - 16-bit reload timer : 1 channel
 - Waveform sequencer : (16-bit timer with buffer and compare clear function)
- Time-base counter/watchdog timer : 18-bit

- Low-power consumption mode :
 - Sleep mode
 - Stop mode
 - CPU intermittent operation mode
- Package :
 - QFP-64 (FPT-64P-M09 : 0.65 mm pitch)
 - QFP-64 (FPT-64P-M06 : 1.00 mm pitch)
 - SDIP-64 (DIP-64P-M01 : 1.78 mm pitch)
- CMOS technology

MB90460 Series

■ PRODUCT LINEUP

Part number Item	MB90V460	MB90F462	MB90462	MB90467
Classification	Development/evaluation product	Mass-produced products (Flash ROM)	Mass-produced products (Mask ROM)	
ROM size	—	64 KBytes		
RAM size	8 KBytes	2 KBytes		
CPU function	Number of Instruction : 351 Minimum execution time : 62.5 ns / 4 MHz (PLL × 4) Addressing mode : 23 Data bit length : 1, 8, 16 bits Maximum memory space : 16 MBytes			
I/O port	I/O port (CMOS) : 51			
PWC	Pulse width counter timer : 2 channels			Pulse width counter timer : 1ch
	Timer function (select the counter timer from three internal clocks) Various Pulse width measuring function (H pulse width, L pulse width, rising edge to falling edge period, falling edge to rising edge period, rising edge to rising edge period and falling edge to falling edge period)			
UART	UART : 2 channels With full-duplex double buffer (8-bit length) Clock asynchronized or clock synchronized transmission (with start and stop bits) can be selectively used Transmission can be one-to-one (bi-directional communication) or one-to-n (Master-Slave communication)			
16-bit reload timer	Reload timer : 2 channels Reload mode, single-shot mode or event count mode selectable Can be worked with a multi-pulse generator or individually			
16-bit PPG timer	PPG timer : 3 channels			PPG timer : 2ch
	PWM mode or single-shot mode selectable Can be worked with multi-functional timer / multi-pulse generator or individually			
Multi-functional timer (for AC/DC motor control)	16-bit free-running timer with up or up/down mode selection and buffer : 1 channel 16-bit output compare : 6 channels 16-bit input capture : 4 channels 16-bit PPG timer : 1 channel Waveform generator (16-bit timer : 3 channels, 3-phase waveform or dead time)			
Multi-pulse generator (for DC motor control)	16-bit PPG timer : 1 channel 16-bit reload timer operation (toggle output, one shot output selectable) Event counter function : 1 channel built-in A waveform sequencer (includes 16-bit timer with buffer and compare clear function)			—
8/10-bit A/D converter	8/10-bit resolution (8 channels) Conversion time : Less than 6.13 μS (16 MHz internal clock)			
DTP/External interrupt	8 independent channels Selectable causes : Rising edge, falling edge, "L" level or "H" level			
Lower power consumption	Stop mode / Sleep mode / CPU intermittent operation mode			

(Continued)

MB90460 Series

(Continued)

Part number Item	MB90V460	MB90F462	MB90462	MB90467
Package	PGA256	LQFP-64 (FPT-64P-M09 : 0.65 mm pitch) QFP-64 (FPT-64P-M06 : 1.00 mm pitch) SDIP-64 (DIP-64P-M01 : 1.78 mm pitch)		
Power supply voltage for operation*	4.5 V to 5.5 V *			
Process	CMOS			

* : Varies with conditions such as the operating frequency (See section “■ ELECTRICAL CHARACTERISTICS”) . Assurance for the MB90V460 is given only for operation with a tool at a power supply voltage of 4.5 V to 5.5 V, an operating temperature of 0 to +25 °C, and an operating frequency of 1 MHz to 16 MHz.

■ PACKAGE AND CORRESPONDING PRODUCTS

Package	MB90V460	MB90F462	MB90462	MB90467
PGA256	○	×	×	×
FPT-64P-M09	×	○	○	○
FPT-64P-M06	×	○	○	○
DIP-64P-M01	×	○	○	○

○ : Available, × : Not available

Note : For more information about each package, see section “■ PACKAGE DIMENSIONS”.

■ DIFFERENCES AMONG PRODUCTS

Memory Size

In evaluation with an evaluation product, note the difference between the evaluation product and the product actually used. The following items must be taken into consideration.

- The MB90V460 does not have an internal ROM, however, operations equivalent to chips with an internal ROM can be evaluated by using a dedicated development tool, enabling selection of ROM size by settings of the development tool.
- In the MB90V460, images from FF4000_H to FFFFFFF_H are mapped to bank 00, and FE0000_H to FF3FFF_H are mapped to bank FF only. (This setting can be changed by configuring the development tool.)
- In the MB90462/F462/467, images from FF4000_H to FFFFFFF_H are mapped to bank 00, and FF0000_H to FF3FFF_H are mapped to bank FF only.

MB90460 Series

PIN ASSIGNMENT

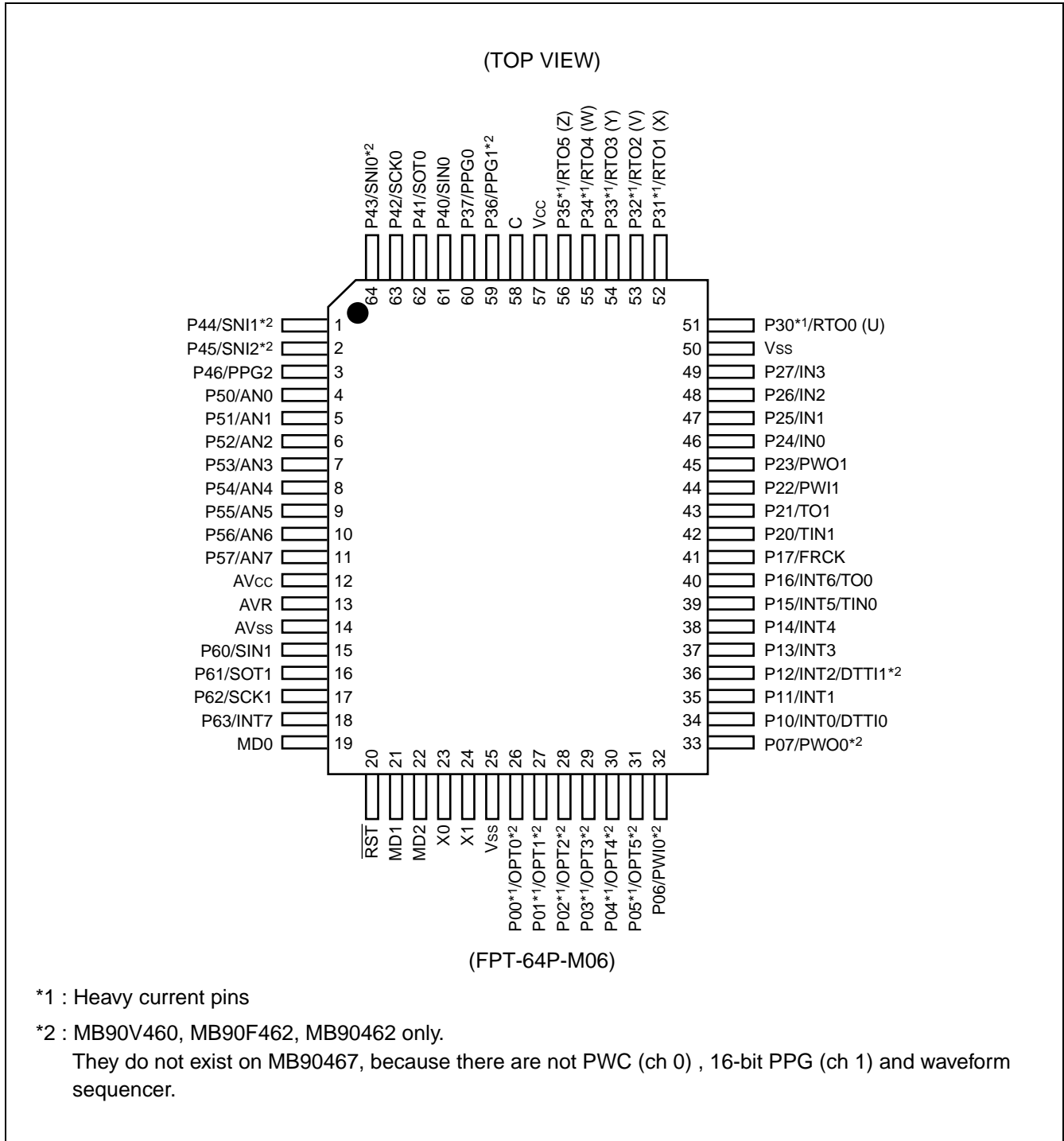

(Continued)

(TOP VIEW)

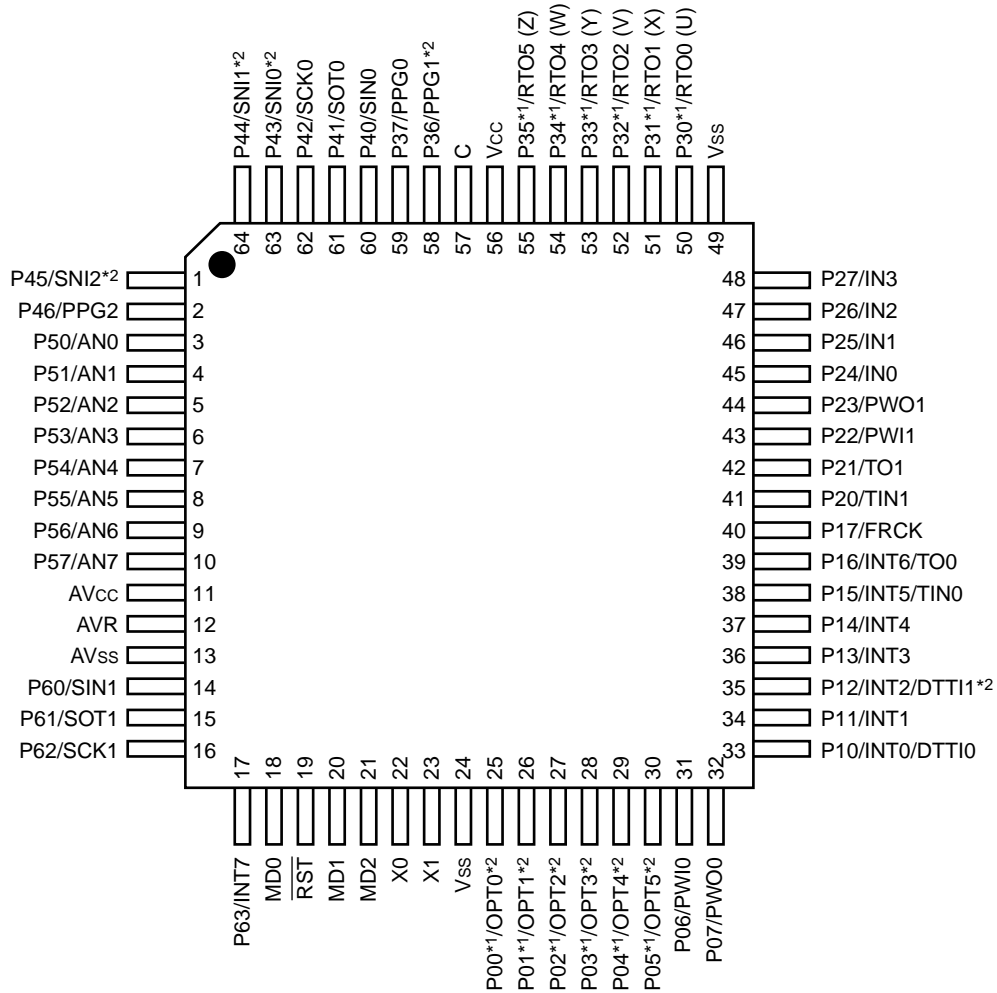

(FPT-64P-M09)

*1 : Heavy current pins

*2 : MB90V460, MB90F462, MB90462 only.

They do not exist on MB90467, because there are not PWC (ch 0) , 16-bit PPG (ch 1) and waveform sequencer.

(Continued)

MB90460 Series

(Continued)

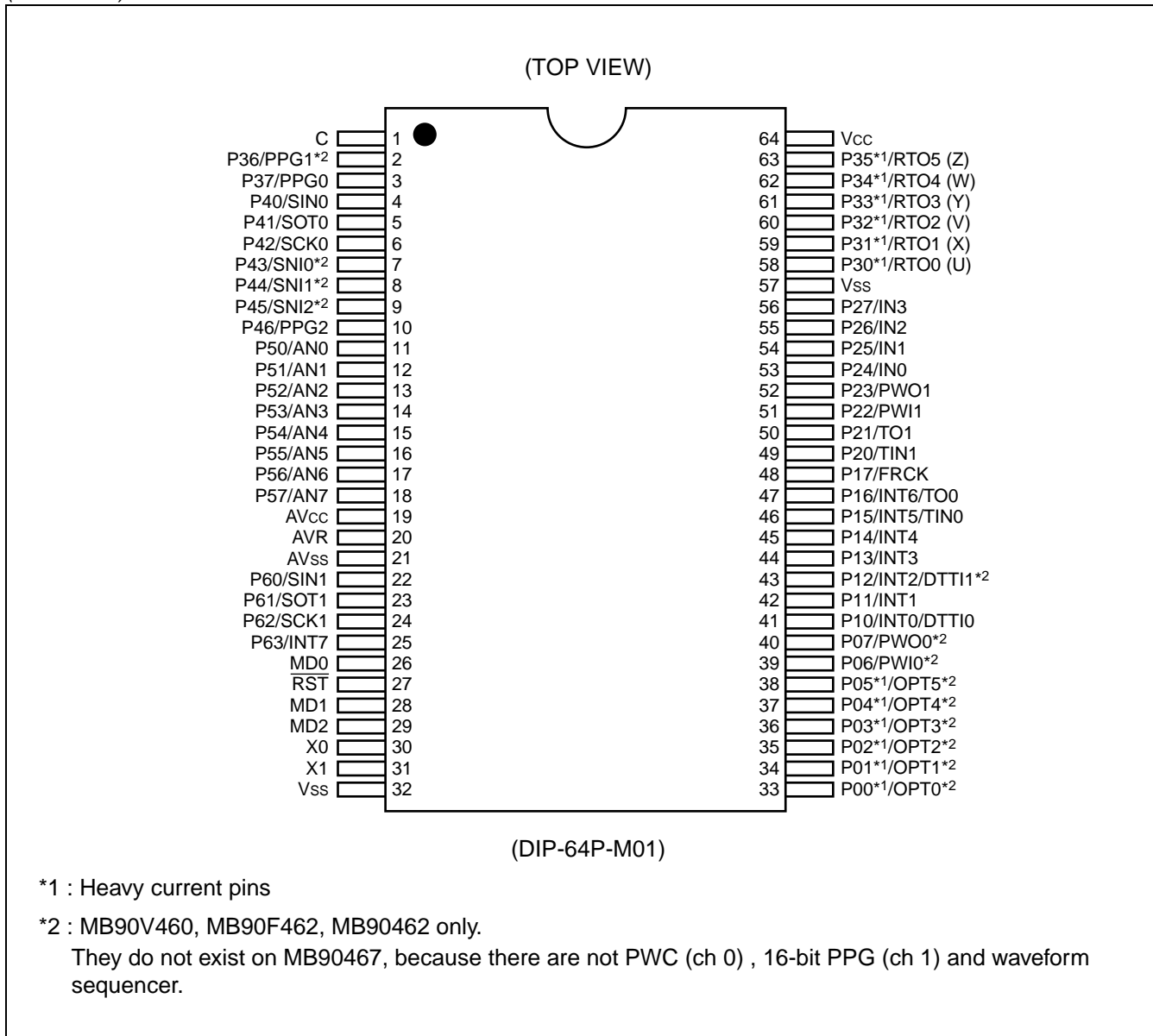

■ PIN DESCRIPTION

Pin No.			Pin name	I/O circuit	Function
QFP-M06*2	LQFP-M09*1	SDIP*3			
23, 24	22, 23	30, 31	X0, X1	A	Oscillation input pins.
20	19	27	\overline{RST}	B	External reset input pin.
26 to 31	25 to 30	33 to 38	P00 to P05	D	General-purpose I/O ports.
			OPT0 to OPT5*4		Output terminals OPT0 to 5 of the waveform sequencer. These pins output the waveforms specified at the output data registers of the waveform sequencer circuit. Output is generated when OPE0 to 5 of OPCR is enabled.*4
32	31	39	P06	E	General-purpose I/O ports.
			PWIO*4		PWC 0 signal input pin.*4
33	32	40	P07	E	General-purpose I/O ports.
			PWO0*4		PWC 0 signal output pin.*4
34	33	41	P10	C	General-purpose I/O ports.
			INT0		Can be used as interrupt request input channels 0. Input is enabled when 1 is set in EN0 in standby mode.
			DTTI0		RTO0 to 5 pins for fixed-level input. This function is enabled when the waveform generator enables its input bits.
35	34	42	P11	C	General-purpose I/O ports.
			INT1		Can be used as interrupt request input channels 1. Input is enabled when 1 is set in EN1 in standby mode.
36	35	43	P12	C	General-purpose I/O ports.
			INT2		Can be used as interrupt request input channels 2. Input is enabled when 1 is set in EN2 in standby mode.
			DTTI1*4		OPT0 to 5 pins for fixed-level input. This function is enabled when the waveform sequencer enables its input bit.*4
37 to 38	36 to 37	44 to 45	P13 to P14	C	General-purpose I/O ports.
			INT3 to INT4		Can be used as interrupt request input channels 3 to 4. Input is enabled when 1 is set in EN3 to EN4 in standby mode.
39	38	46	P15	C	General-purpose I/O ports.
			INT5		Can be used as interrupt request input channel 5. Input is enabled when 1 is set in EN5 in standby mode.
			TIN0		External clock input pin for reload timer 0.

(Continued)

MB90460 Series

Pin No.			Pin name	I/O circuit	Function
QFP-M06*2	LQFP-M09*1	SDIP*3			
40	39	47	P16	C	General-purpose I/O ports.
			INT6		Can be used as interrupt request input channels 6. Input is enabled when 1 is set in EN6 in standby mode.
			TO0		Event output pin for reload timer 0.
41	40	48	P17	C	General-purpose I/O ports.
			FRCK		External clock input pin for free-running timer.
42	41	49	P20	F	General-purpose I/O ports.
			TIN1		External clock input pin for reload timer 1.
43	42	50	P21	F	General-purpose I/O ports.
			TO1		Event output pin for reload timer 1.
44	43	51	P22	F	General-purpose I/O ports.
			PWI1		PWC 1 signal input pin.
45	44	52	P23	F	General-purpose I/O ports.
			PWO1		PWC 1 signal output pin.
46 to 49	45 to 48	53 to 56	P24 to P27	F	General-purpose I/O ports.
			IN0 to IN3		Trigger input pins for input capture channels 0 to 3. When input capture channels 0 to 3 are used for input operation, these pins are enabled as required and must not be used for any other I/P.
51 to 56	50 to 55	58 to 63	P30 to P35	G	General-purpose I/O ports.
			RTO0(U) to RTO5(Z)		Waveform generator output pins. These pins output the waveforms specified at the waveform generator. Output is generated when waveform generator output is enabled. (U) to (Z) show the coils that control 3-phase motor.
59	58	2	P36	H	General-purpose I/O ports.
			PPG1*4		Output pins for PPG channels 1. This function is enabled when PPG channels 1 enable output.*4
60	59	3	P37	H	General-purpose I/O ports.
			PPG0		Output pins for PPG channels 0. This function is enabled when PPG channels 0 enable output.
61	60	4	P40	F	General-purpose I/O ports.
			SIN0		Serial data input pin for UART channel 0. While UART channel 0 is operating for input, the input of this pin is used as required and must not be used for any other input.
62	61	5	P41	F	General-purpose I/O ports.
			SOT0		Serial data output pin for UART channel 0. This function is enabled when UART channel 0 enables data output.

MB90460 Series

(Continued)

(Continued)

Pin No.			Pin name	I/O circuit	Function
QFP-M06*2	LQFP-M09*1	SDIP*3			
63	62	6	P42	F	General-purpose I/O ports.
			SCK0		Serial clock I/O pin for UART channel 0. This function is enabled when UART channel 0 enables clock output.
64	63	7	P43	F	General-purpose I/O ports.
			SNI0*4		Trigger input pins for position detection of the waveform sequencer. When this pin is used for input operation, it is enabled as required and must not be used for any other I/P.*4
1	64	8	P44	F	General-purpose I/O ports.
			SNI1*4		Trigger input pins for position detection of the Multi-pulse generator. When this pin is used for input operation, it is enabled as required and must not be used for any other I/P.*4
2	1	9	P45	F	General-purpose I/O ports.
			SNI2*4		Trigger input pins for position detection of the Multi-pulse generator. When this pin is used for input operation, it is enabled as required and must not be used for any other I/P.*4
3	2	10	P46	F	General-purpose I/O ports.
			PPG2		Output pins for PPG channel 2. This function is enabled when PPG channel 2 enables output.
4 to 11	3 to 10	11 to 18	P50 to P57	I	General-purpose I/O ports.
			AN0 to AN7		A/D converter analog input pins. This function is enabled when the analog input specification is enabled. (ADER) .
12	11	19	AV _{cc}	—	V _{cc} power input pin for analog circuits.
13	12	20	AVR	—	Reference voltage (+) input pin for the A/D converter. This voltage must not exceed V _{cc} and AV _{cc} . Reference voltage (–) is fixed to AV _{ss} .
14	13	21	AV _{ss}	—	V _{ss} power input pin for analog circuits.
15	14	22	P60	F	General-purpose I/O ports.
			SIN1		Serial data input pin for UART channel 1. While UART channel 1 is operating for input, the input of this pin is used as required and must not be used for any other in-put.
16	15	23	P61	F	General-purpose I/O ports.
			SOT1		Serial data output pin for UART channel 1. This function is enabled when UART channel 1 enables data output.

(Continued)

MB90460 Series

(Continued)

Pin No.			Pin name	I/O circuit	Function
QFP-M06*2	LQFP-M09*1	SDIP*3			
17	16	24	P62	F	General-purpose I/O port.
			SCK1		Serial clock I/O pin for UART channel 1. This function is enabled when UART channel 1 enables clock output.
18	17	25	P63	F	General-purpose I/O port.
			INT7		Usable as interrupt request input channel 7. Input is enabled when 1 is set in EN7 in standby mode.
19	18	26	MD0	J	Input pin for operation mode specification. Connect this pin directly to V _{CC} or V _{SS} .
21, 22	20, 21	28, 29	MD1, MD2	J	Input pin for operation mode specification. Connect this pin directly to V _{CC} or V _{SS} .
25, 50	24, 49	32, 57	V _{SS}	—	Power (0 V) input pin.
57	56	64	V _{CC}	—	Power (5 V) input pin.
58	57	1	C	—	Capacity pin for power stabilization. Please connect to an approximately 0.1 μF ceramic capacitor.

*1 : FPT-64P-M09

*2 : FPT-64P-M06

*3 : DIP-64P-M01

*4 : MB90V460, MB90F462, MB90462 only.

They do not exist on MB90467, because there are not PWC (ch 0) , 16-bit PPG (ch 1) and waveform sequencer.

■ I/O CIRCUIT TYPE

Classification	Type	Remarks
A		<p>Main clock (main clock crystal oscillator)</p> <ul style="list-style-type: none"> • At an oscillation feedback resistor of approximately 1 MΩ
B		<ul style="list-style-type: none"> • Hysteresis input • Pull-up resistor approximately 50 kΩ
C		<ul style="list-style-type: none"> • CMOS output • Hysteresis input • Selectable pull-up resistor approximately 50 kΩ • $I_{OL} = 4$ mA • Standby control available
D		<ul style="list-style-type: none"> • CMOS output • CMOS input • Selectable pull-up resistor approximately 50 kΩ • Standby control available • $I_{OL} = 12$ mA

(Continued)

MB90460 Series

Classification	Type	Remarks
E		<ul style="list-style-type: none"> • CMOS output • CMOS input • Selectable pull-up resistor approximately 50 kΩ • Standby control available • I_{OL} = 4 mA
F		<ul style="list-style-type: none"> • CMOS output • Hysteresis input • Standby control available • I_{OL} = 4 mA
G		<ul style="list-style-type: none"> • CMOS output • CMOS input • Standby control available • I_{OL} = 12 mA
H		<ul style="list-style-type: none"> • CMOS output • CMOS input • Standby control available • I_{OL} = 4 mA

(Continued)

(Continued)

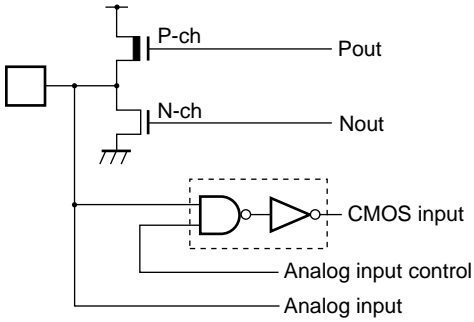
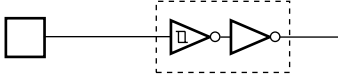
Classification	Type	Remarks
I	 <p>The diagram shows a CMOS output stage with a P-channel MOSFET (P-ch) and an N-channel MOSFET (N-ch). The gates of both transistors are connected to a common input node. The P-ch MOSFET's source is connected to V_{DD} and its drain is labeled Pout. The N-ch MOSFET's source is connected to ground and its drain is labeled Nout. Below this, there is a CMOS input stage consisting of an AND gate and an inverter. The AND gate has two inputs: 'Analog input control' and 'Analog input'. Its output is connected to the input of an inverter, which is labeled 'CMOS input'.</p>	<ul style="list-style-type: none"> • CMOS output • CMOS input • Analog input • I_{OL} = 4 mA
J	 <p>The diagram shows a hysteresis input stage. It consists of two inverters connected in a feedback loop. The output of the first inverter is connected to the input of the second inverter, and the output of the second inverter is connected back to the input of the first inverter. The input of the first inverter is connected to a square symbol representing an external input.</p>	<ul style="list-style-type: none"> • Hysteresis input

MB90460 Series

■ HANDLING DEVICES

1. Preventing Latchup

CMOS ICs may cause latchup in the following situations :

- When a voltage higher than V_{CC} or lower than V_{SS} is applied to input or output pins.
- When a voltage exceeding the rating is applied between V_{CC} and V_{SS} .
- When AV_{CC} power is supplied prior to the V_{CC} voltage.

If latchup occurs, the power supply current increases rapidly, sometimes resulting in thermal breakdown of the device. Use meticulous care not to let it occur.

For the same reason, also be careful not to let the analog power-supply voltage exceed the digital power-supply voltage.

2. Handling unused input pins

Unused input pins left open may cause abnormal operation, or latch-up leading to permanent damage. Unused input pins should be pulled up or pulled down through at least 2 k Ω resistance.

Unused input/output pins may be left open in the output state, but if such pins are in the input state they should be handled in the same way as input pins.

3. Use of the external clock

When the device uses an external clock, drive only the X0 pin while leaving the X1 pin open (See the illustration below) .

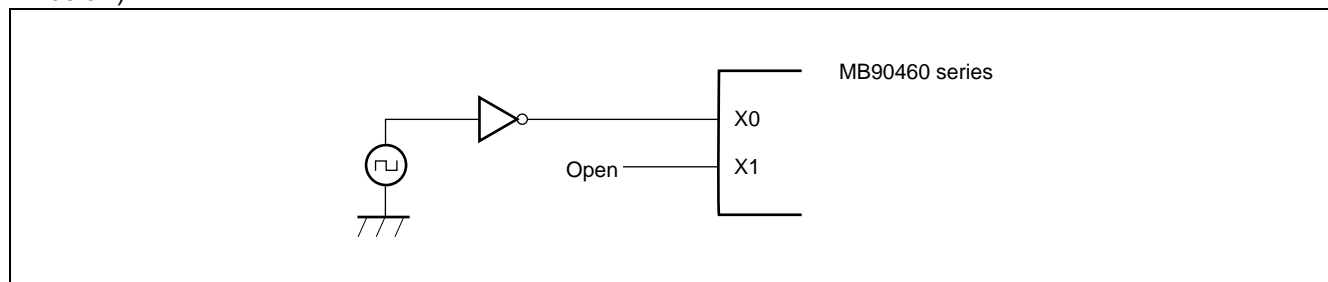

4. Power Supply Pins (V_{CC}/V_{SS})

In products with multiple V_{CC} or V_{SS} pins, the pins of a same potential are internally connected in the device to avoid abnormal operations including latch-up. However, connect the pins external power and ground lines to lower the electro-magnetic emission level to prevent abnormal operation of strobe signals caused by the rise in the ground level, and to conform to the total current rating.

Make sure to connect V_{CC} and V_{SS} pins via the lowest impedance to power lines.

It is recommended to provide a bypass capacitor of around 0.1 μ F between V_{CC} and V_{SS} pins near the device.

5. Crystal Oscillator Circuit

Noise around X0 or X1 pins may cause abnormal operations. Make sure to provide bypass capacitors via the shortest distance from X0, X1 pins, crystal oscillator (or ceramic resonator) and ground lines, and make sure, to the utmost effort, that lines of oscillation circuit not cross the lines of other circuits.

It is highly recommended to provide a printed circuit board art work surrounding X0 and X1 pins with the ground area for stabilizing the operation.

6. Turning-on Sequence of Power Supply to A/D Converter and Analog Inputs

Make sure to turn on the A/D converter power supply (AV_{CC} , AV_{SS} , AVR) and analog inputs (AN0 to AN7) after turning-on the digital power supply (V_{CC}) .

Turn-off the digital power after turning off the A/D converter supply and analog inputs. In this case, make sure that the voltage of AVR dose not exceed AV_{CC} (turning on/off the analog and digital power supplies simultaneously is acceptable) .

7. Connection of Unused Pins of A/D Converter

Connect unused pin of A/D converter to $AV_{CC} = V_{CC}$, $AV_{SS} = AVR = V_{SS}$.

8. N.C. Pin

The N.C. (internally connected) pin must be opened for use.

9. Notes on Energization

To prevent the internal regulator circuit from malfunctioning, set the voltage rise time during energization at 50 μ s or more.

10. Initialization

In the device, there are internal registers which are initialized only by a power-on reset. To initialize these registers, please turn on the power again.

11. Return from standby state

If the power-supply voltage goes below the standby RAM holding voltage in the standby state, the device may fail to return from the standby state. In this case, reset the device via the external reset pin to return to the normal state.

MB90460 Series

■ BLOCK DIAGRAM

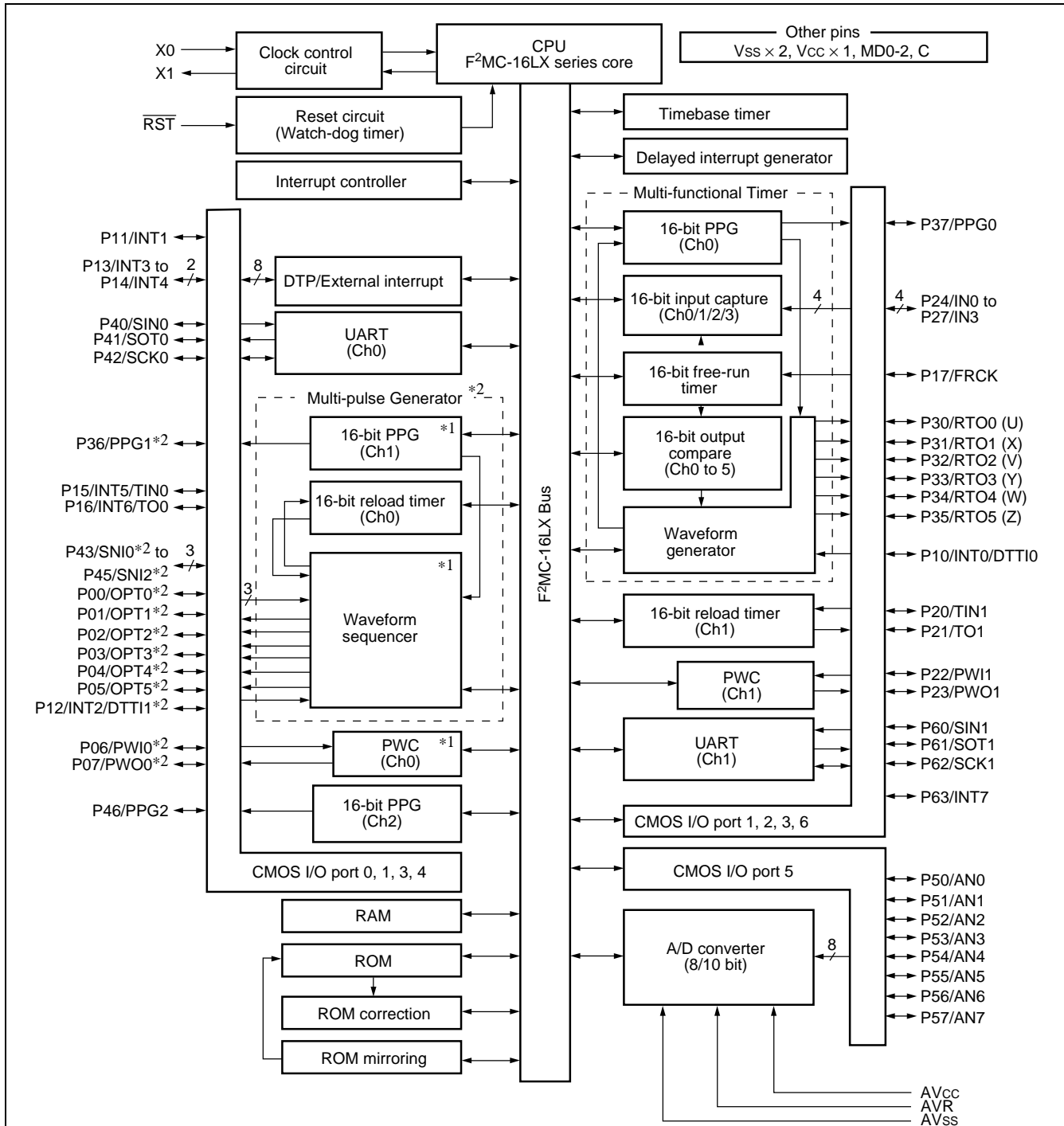

Note : P00 to P07 (8 channels) : With registers that can be used as input pull-up resistors

P10 to P17 (8 channels) : With registers that can be used as input pull-up resistors

*1: Only MB90V460, MB90F462 and MB90462 have PWC (ch 0) , 16-bit PPG (ch 1) and waveform sequencer. They do not exist on MB90467.

*2: The multi-pulse generator function can be used only by MB90V460, MB90F462 and MB90462. This function can not be used by MB90467.

MEMORY MAP

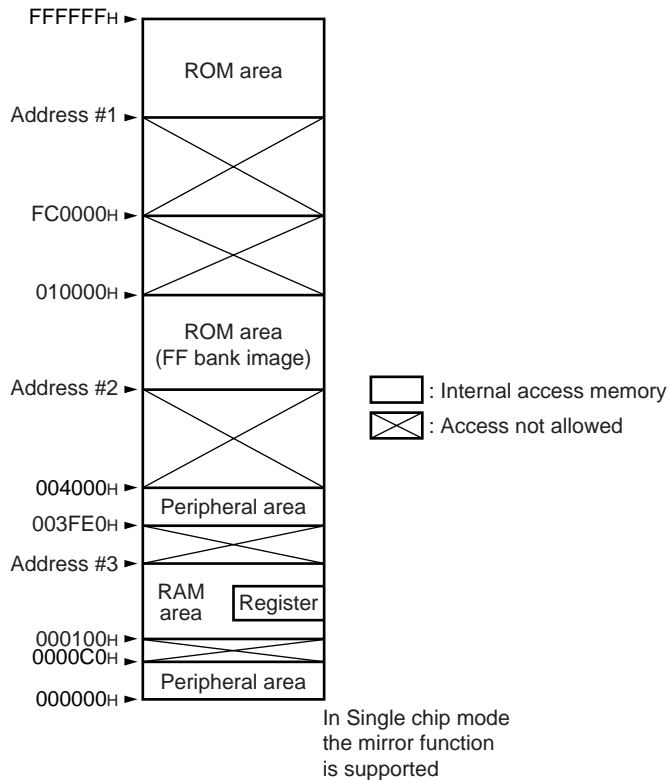

Parts No.	Address#1	Address#2	Address#3
MB90462/467	FF0000 _H	004000 _H	000900 _H
MB90F462	FF0000 _H	004000 _H	000900 _H
MB90V460	(FF0000 _H)	004000 _H	002100 _H

Note : The ROM data of bank FF is reflected in the upper address of bank 00, realizing effective use of the C compiler small model. The lower 16-bit is assigned to the same address, enabling reference of the table on the ROM without stating "far". For example, if an attempt has been made to access 00C000_H, the contents of the ROM at FFC000_H are accessed actually. Since the ROM area of the FF bank exceeds 48 Kbytes, the whole area cannot be reflected in the image for the 00 bank. The ROM data at FF4000_H to FFFFFFF_H looks, therefore, as if it were the image for 004000_H to 00FFFF_H. Thus, it is recommended that the ROM data table be stored in the area of FF4000_H to FFFFFFF_H.

MB90460 Series

■ I/O MAP

Address	Abbreviation	Register	Byte access	Word access	Resource name	Initial value
00000H	PDR0	Port 0 data register	R/W	R/W	Port 0	XXXXXXXX _B
00001H	PDR1	Port 1 data register	R/W	R/W	Port 1	XXXXXXXX _B
00002H	PDR2	Port 2 data register	R/W	R/W	Port 2	XXXXXXXX _B
00003H	PDR3	Port 3 data register	R/W	R/W	Port 3	XXXXXXXX _B
00004H	PDR4	Port 4 data register	R/W	R/W	Port 4	-XXXXXXXX _B
00005H	PDR5	Port 5 data register	R/W	R/W	Port 5	XXXXXXXX _B
00006H	PDR6	Port 6 data register	R/W	R/W	Port 6	----XXXX _B
00007H	Prohibited area					
00008H	PWCSL0	PWC control status register CH0	R/W	R/W	PWC timer (CH0)	0000000 _B
00009H	PWCSH0		R/W	R/W		0000000 _B
0000AH	PWC0	PWC data buffer register CH0	—	R/W		XXXXXXXX _B
0000BH			XXXXXXXX _B			
0000CH	DIV0	Divide ratio control register CH0	R/W	R/W		-----00 _B
0000DH to 0FH	Prohibited area					
00010H	DDR0	Port 0 direction register	R/W	R/W	Port 0	0000000 _B
00011H	DDR1	Port 1 direction register	R/W	R/W	Port 1	0000000 _B
00012H	DDR2	Port 2 direction register	R/W	R/W	Port 2	0000000 _B
00013H	DDR3	Port 3 direction register	R/W	R/W	Port 3	0000000 _B
00014H	DDR4	Port 4 direction register	R/W	R/W	Port 4	-000000 _B
00015H	DDR5	Port 5 direction register	R/W	R/W	Port 5	0000000 _B
00016H	DDR6	Port 6 direction register	R/W	R/W	Port 6	----0000 _B
00017H	ADER	Analog input enable register	R/W	R/W	Port 5, A/D	1111111 _B
00018H	Prohibited area					
00019H	CDCR0	Clock division control register 0	R/W	R/W	Communication prescaler 0	0---0000 _B
0001AH	Prohibited area					
0001BH	CDCR1	Clock division control register 1	R/W	R/W	Communication prescaler 1	0---0000 _B
0001CH	RDR0	Port 0 pull-up resistor setting register	R/W	R/W	Port 0	0000000 _B
0001DH	RDR1	Port 1 pull-up resistor setting register	R/W	R/W	Port 1	0000000 _B
0001EH to 1FH	Prohibited area					

(Continued)

MB90460 Series

Address	Abbreviation	Register	Byte access	Word access	Resource name	Initial value
000020 _H	SMR0	Serial mode register 0	R/W	R/W	UART0	00000000 _B
000021 _H	SCR0	Serial control register 0	R/W	R/W		00000100 _B
000022 _H	SIDR0 / SODR0	Input data register 0 / output data register 0	R/W	R/W		XXXXXXXX _B
000023 _H	SSR0	Serial status register 0	R/W	R/W		00001000 _B
000024 _H	SMR1	Serial mode register 1	R/W	R/W	UART1	00000000 _B
000025 _H	SCR1	Serial control register 1	R/W	R/W		00000100 _B
000026 _H	SIDR1 / SODR1	Input data register 1 / output data register 1	R/W	R/W		XXXXXXXX _B
000027 _H	SSR1	Status register 1	R/W	R/W		00001000 _B
000028 _H	PWCSL1	PWC control status register CH1	R/W	R/W	PWC timer (CH1)	00000000 _B
000029 _H	PWCSH1		R/W	R/W		00000000 _B
00002A _H	PWC1	PWC data buffer register CH1	—	R/W		XXXXXXXX _B
00002B _H			XXXXXXXX _B			
00002C _H	DIV1	Divide ratio control register CH1	R/W	R/W		-----00 _B
00002D _H to 2F _H	Prohibited area					
000030 _H	ENIR	Interrupt / DTP enable register	R/W	R/W	DTP/external interrupt	00000000 _B
000031 _H	EIRR	Interrupt / DTP cause register	R/W	R/W		XXXXXXXX _B
000032 _H	ELVRL	Request level setting register (Lower Byte)	R/W	R/W		00000000 _B
000033 _H	ELVRH	Request level setting register (Higher Byte)	R/W	R/W		00000000 _B
000034 _H	ADCS0	A/D control status register 0	R/W	R/W	8/10-bit A/D converter	00000000 _B
000035 _H	ADCS1	A/D control status register 1	R/W	R/W		00000000 _B
000036 _H	ADCR0	A/D data register 0	R	R		XXXXXXXX _B
000037 _H	ADCR1	A/D data register 1	R/W	R/W		0000-XX _B
000038 _H	PDCR0	PPG0 down counter register	—	R	16-bit PPG timer (CH0)	11111111 _B
000039 _H						11111111 _B
00003A _H	PCSR0	PPG0 period setting register	—	W		XXXXXXXX _B
00003B _H						XXXXXXXX _B
00003C _H	PDUT0	PPG0 duty setting register	—	W		XXXXXXXX _B
00003D _H						XXXXXXXX _B
00003E _H	PCNTL0	PPG0 control status register	R/W	R/W		--00000 _B
00003F _H	PCNTH0		R/W	R/W		00000000 _B

(Continued)

MB90460 Series

Address	Abbreviation	Register	Byte access	Word access	Resource name	Initial value	
000040 _H	PDCR1	PPG1 down counter register	—	R	16-bit PPG timer (CH1)	11111111 _B	
000041 _H						11111111 _B	
000042 _H	PCSR1	PPG1 period setting register	—	W		XXXXXXXX _B	
000043 _H						XXXXXXXX _B	
000044 _H	PDUT1	PPG1 duty setting register	—	W		XXXXXXXX _B	
000045 _H						XXXXXXXX _B	
000046 _H	PCNTL1	PPG1 control status register	R/W	R/W		--000000 _B	
000047 _H	PCNTH1		R/W	R/W		00000000 _B	
000048 _H	PDCR2	PPG2 down counter register	—	R		16-bit PPG timer (CH2)	11111111 _B
000049 _H							11111111 _B
00004A _H	PCSR2	PPG2 period setting register	—	W	XXXXXXXX _B		
00004B _H					XXXXXXXX _B		
00004C _H	PDUT2	PPG2 duty setting register	—	W	XXXXXXXX _B		
00004D _H					XXXXXXXX _B		
00004E _H	PCNTL2	PPG2 control status register	R/W	R/W	--000000 _B		
00004F _H	PCNTH2		R/W	R/W	00000000 _B		
000050 _H	TMRR0	16-bit timer register 0	—	R/W	Waveform generator		XXXXXXXX _B
000051 _H							XXXXXXXX _B
000052 _H	TMRR1	16-bit timer register 1	—	R/W		XXXXXXXX _B	
000053 _H						XXXXXXXX _B	
000054 _H	TMRR2	16-bit timer register 2	—	R/W		XXXXXXXX _B	
000055 _H						XXXXXXXX _B	
000056 _H	DTCR0	16-bit timer control register 0	R/W	R/W		00000000 _B	
000057 _H	DTCR1	16-bit timer control register 1	R/W	R/W		00000000 _B	
000058 _H	DTCR2	16-bit timer control register 2	R/W	R/W		00000000 _B	
000059 _H	SIGCR	Waveform control register	R/W	R/W		00000000 _B	
00005A _H	CPCLRB / CPCLR	Compare clear buffer register / Compare clear register (lower)	—	R/W	16-bit free-running timer	11111111 _B	
00005B _H						11111111 _B	
00005C _H	TCDT	Timer data register (lower)	—	R/W		00000000 _B	
00005D _H						00000000 _B	
00005E _H	TCCSL	Timer control status register (lower)	R/W	R/W		00000000 _B	
00005F _H	TCCSH	Timer control status register (upper)	R/W	R/W		-0000000 _B	

(Continued)

MB90460 Series

Address	Abbreviation	Register	Byte access	Word access	Resource name	Initial value	
000060 _H	IPCP0	Input capture data register CH0	—	R	16-bit input capture (CH0 to CH3)	XXXXXXXX _B	
000061 _H						XXXXXXXX _B	
000062 _H	IPCP1	Input capture data register CH1	—	R		XXXXXXXX _B	
000063 _H						XXXXXXXX _B	
000064 _H	IPCP2	Input capture data register CH2	—	R		XXXXXXXX _B	
000065 _H						XXXXXXXX _B	
000066 _H	IPCP3	Input capture data register CH3	—	R		XXXXXXXX _B	
000067 _H						XXXXXXXX _B	
000068 _H	PICSL01	PPG output control / Input capture control status register 01 (lower)	R/W	R/W			00000000 _B
000069 _H	PICSH01	PPG output control / Input capture control status register 01 (upper)	R/W	R/W			00000000 _B
00006A _H	ICSL23	Input capture control status register 23 (lower)	R/W	R/W		00000000 _B	
00006B _H	ICSH23	Input capture control status register 23 (upper)	R	R		-----00 _B	
00006C _H to 6E _H	Prohibited area						
00006F _H	ROMM	ROM mirroring function selection register	W	W	ROM mirroring function	-----1 _B	
000070 _H	OCCPB0/ OCCP0	Output compare buffer register / output compare register 0	—	R/W	Output compare (CH0 to CH5)	XXXXXXXX _B	
000071 _H						XXXXXXXX _B	
000072 _H	OCCPB1/ OCCP1	Output compare buffer register / output compare register 1	—	R/W		XXXXXXXX _B	
000073 _H						XXXXXXXX _B	
000074 _H	OCCPB2/ OCCP2	Output compare buffer register / output compare register 2	—	R/W		XXXXXXXX _B	
000075 _H						XXXXXXXX _B	
000076 _H	OCCPB3/ OCCP3	Output compare buffer register / output compare register 3	—	R/W		XXXXXXXX _B	
000077 _H						XXXXXXXX _B	
000078 _H	OCCPB4/ OCCP4	Output compare buffer register / output compare register 4	—	R/W		XXXXXXXX _B	
000079 _H						XXXXXXXX _B	
00007A _H	OCCPB5/ OCCP5	Output compare buffer register / output compare register 5	—	R/W	XXXXXXXX _B		
00007B _H					XXXXXXXX _B		

(Continued)

MB90460 Series

Address	Abbreviation	Register	Byte access	Word access	Resource name	Initial value
00007C _H	OCS0	Compare control register 0	R/W	R/W	Output compare (CH0 to CH5)	00000000 _B
00007D _H	OCS1	Compare control register 1	R/W	R/W		-00000000 _B
00007E _H	OCS2	Compare control register 2	R/W	R/W		00000000 _B
00007F _H	OCS3	Compare control register 3	R/W	R/W		-00000000 _B
000080 _H	OCS4	Compare control register 4	R/W	R/W		00000000 _B
000081 _H	OCS5	Compare control register 5	R/W	R/W		-00000000 _B
000082 _H	TMCSRL0	Timer control status register CH0 (lower)	R/W	R/W	16-bit reload timer (CH0)	00000000 _B
000083 _H	TMCSRH0	Timer control status register CH0 (upper)	R/W	R/W		----0000 _B
000084 _H	TMR0 / TMRD0	16 bit timer register CH0 /	—	R/W		XXXXXXXX _B
000085 _H		16-bit reload register CH0				XXXXXXXX _B
000086 _H	TMCSRL1	Timer control status register CH1 (lower)	R/W	R/W	16-bit reload timer (CH1)	00000000 _B
000087 _H	TMCSRH1	Timer control status register CH1 (upper)	R/W	R/W		----0000 _B
000088 _H	TMR1 / TMRD1	16 bit timer register CH1 /	—	R/W		XXXXXXXX _B
000089 _H		16-bit reload register CH1				XXXXXXXX _B
00008A _H	OPCLR	Output control lower register	R/W	R/W	Waveform sequencer	00000000 _B
00008B _H	OPCUR	Output control upper register	R/W	R/W		00000000 _B
00008C _H	IPCLR	Input control lower register	R/W	R/W		00000000 _B
00008D _H	IPCUR	Input control upper register	R/W	R/W		00000000 _B
00008E _H	TCSR	Timer control status register	R/W	R/W		00000000 _B
00008F _H	NCCR	Noise cancellation control register	R/W	R/W		00000000 _B
000090 _H to 9D _H	Prohibited area					
00009E _H	PACSR	Program address detect control status register	R/W	R/W	Rom correction	00000000 _B
00009F _H	DIRR	Delayed interrupt cause / clear register	R/W	R/W	Delayed interrupt	-----0 _B
0000A0 _H	LPMCR	Low-power consumption mode register	R/W	R/W	Low-power consumption control register	00011000 _B
0000A1 _H	CKSCR	Clock selection register	R/W	R/W		11111100 _B
0000A2 _H to A7 _H	Prohibited area					
0000A8 _H	WDTC	Watchdog control register	R/W	R/W	Watchdog timer	X-XXX111 _B
0000A9 _H	TBTC	Timebase timer control register	R/W	R/W	Timebase timer	1--00100 _B

(Continued)

MB90460 Series

Address	Abbreviation	Register	Byte access	Word access	Resource name	Initial value
0000AA _H to AD _H	Prohibited area					
0000AE _H	FMCS	Flash memory control status register	R/W	R/W	Flash memory interface circuit	00010000 _B
0000AF _H	Prohibited area					
0000B0 _H	ICR00	Interrupt control register 00	R/W	R/W	Interrupt controller	00000111 _B
0000B1 _H	ICR01	Interrupt control register 01	R/W	R/W		00000111 _B
0000B2 _H	ICR02	Interrupt control register 02	R/W	R/W		00000111 _B
0000B3 _H	ICR03	Interrupt control register 03	R/W	R/W		00000111 _B
0000B4 _H	ICR04	Interrupt control register 04	R/W	R/W		00000111 _B
0000B5 _H	ICR05	Interrupt control register 05	R/W	R/W		00000111 _B
0000B6 _H	ICR06	Interrupt control register 06	R/W	R/W		00000111 _B
0000B7 _H	ICR07	Interrupt control register 07	R/W	R/W		00000111 _B
0000B8 _H	ICR08	Interrupt control register 08	R/W	R/W		00000111 _B
0000B9 _H	ICR09	Interrupt control register 09	R/W	R/W		00000111 _B
0000BA _H	ICR10	Interrupt control register 10	R/W	R/W		00000111 _B
0000BB _H	ICR11	Interrupt control register 11	R/W	R/W		00000111 _B
0000BC _H	ICR12	Interrupt control register 12	R/W	R/W		00000111 _B
0000BD _H	ICR13	Interrupt control register 13	R/W	R/W		00000111 _B
0000BE _H	ICR14	Interrupt control register 14	R/W	R/W		00000111 _B
0000BF _H	ICR15	Interrupt control register 15	R/W	R/W		00000111 _B
0000C0 _H to FF _H	External area					
001FF0 _H	PADR0L	Program address detection register 0 (Lower Byte)	R/W	R/W	Rom correction	XXXXXXXX _B
001FF1 _H	PADR0M	Program address detection register 0 (Middle Byte)	R/W	R/W		XXXXXXXX _B
001FF2 _H	PADR0H	Program address detection register 0 (Higher Byte)	R/W	R/W		XXXXXXXX _B
001FF3 _H	PADR1L	Program address detection register 1 (Lower Byte)	R/W	R/W		XXXXXXXX _B
001FF4 _H	PADR1M	Program address detection register 1 (Middle Byte)	R/W	R/W		XXXXXXXX _B
001FF5 _H	PADR1H	Program address detection register 1 (Higher Byte)	R/W	R/W		XXXXXXXX _B

(Continued)

MB90460 Series

(Continued)

Address	Abbreviation	Register	Byte access	Word access	Resource name	Initial value	
003FE0 _H	OPDBR0	Output data buffer register 0	—	R/W	Waveform sequencer	00000000 _B	
003FE1 _H						00000000 _B	
003FE2 _H	OPDBR1	Output data buffer register 1	—	R/W		00000000 _B	
003FE3 _H						00000000 _B	
003FE4 _H	OPDBR2	Output data buffer register 2	—	R/W		00000000 _B	
003FE5 _H						00000000 _B	
003FE6 _H	OPDBR3	Output data buffer register 3	—	R/W		00000000 _B	
003FE7 _H						00000000 _B	
003F78 _H	OPDBR4	Output data buffer register 4	—	R/W		00000000 _B	
003FE9 _H						00000000 _B	
003FEA _H	OPDBR5	Output data buffer register 5	—	R/W		00000000 _B	
003FEB _H						00000000 _B	
003FEC _H	OPEBR6	Output data buffer register 6	—	R/W		00000000 _B	
003FED _H						00000000 _B	
003FEE _H	OPEBR7	Output data buffer register 7	—	R/W		00000000 _B	
003FEF _H						00000000 _B	
003FF0 _H	OPEBR8	Output data buffer register 8	—	R/W		00000000 _B	
003FF1 _H						00000000 _B	
003FF2 _H	OPEBR9	Output data buffer register 9	—	R/W		00000000 _B	
003FF3 _H						00000000 _B	
003FF4 _H	OPEBRA	Output data buffer register A	—	R/W		00000000 _B	
003FF5 _H						00000000 _B	
003FF6 _H	OPEBRB	Output data buffer register B	—	R/W		00000000 _B	
003FF7 _H						00000000 _B	
003FF8 _H	OPDR	Output data register	—	R		XXXXXXXX _B	
003FF9 _H						0000XXXX _B	
003FFA _H	CPCR	Compare clear register	—	R/W		XXXXXXXX _B	
003FFB _H						XXXXXXXX _B	
003FFC _H	TMBR	Timer buffer register	—	R		00000000 _B	
003FFD _H						00000000 _B	
003FFE _H to 003FFF _H	Prohibited area						

- Meaning of abbreviations used for reading and writing

R/W : Read and write enabled

R : Read only

W : Write only

- Explanation of initial values

0 : The bit is initialized to 0.

1 : The bit is initialized to 1.

X : The initial value of the bit is undefined.

- : The bit is not used. Its initial value is undefined.

The Instruction using IO addressing e.g. MOV A, io, is not supported for registers area 003FE0_H to 003FFF_H.

Note : For bits that is initialized by an reset operation, the initial value set by the reset operation is listed as an initial value. Note that the values are different from reading results.

For LPMCR/CKSCR/WDTC, there are cases where initialization is performed or not performed, depending on the types of the reset. However, initial value for resets that initializes the value is listed.

MB90460 Series

■ INTERRUPT FACTORS, INTERRUPT VECTORS, INTERRUPT CONTROL REGISTER

Interrupt cause	EI ² OS support	Interrupt vector		Interrupt control register		Priority ^{*2}	
		Number	Address	ICR	Address		
Reset	×	#08	08 _H	FFFFDC _H	—	—	High ↑
INT9 instruction	×	#09	09 _H	FFFFD8 _H	—	—	
Exception processing	×	#10	0A _H	FFFFD4 _H	—	—	
A/D converter conversion termination	○	#11	0B _H	FFFFD0 _H	ICR00	0000B0 _H ^{*1}	
Output compare channel 0 match	○	#12	0C _H	FFFFCC _H			
End of measurement by PWC0 timer / PWC0 timer overflow	○	#13	0D _H	FFFFC8 _H	ICR01	0000B1 _H ^{*1}	
16-bit PPG timer 0	○	#14	0E _H	FFFFC4 _H			
Output compare channel 1 match	○	#15	0F _H	FFFFC0 _H	ICR02	0000B2 _H ^{*1}	
16-bit PPG timer 1	○	#16	10 _H	FFFFBC _H			
Output compare channel 2 match	○	#17	11 _H	FFFFB8 _H	ICR03	0000B3 _H ^{*1}	
16-bit reload timer 1 underflow	○	#18	12 _H	FFFFB4 _H			
Output compare channel 3 match	○	#19	13 _H	FFFFB0 _H	ICR04	0000B4 _H ^{*1}	
DTP/ext. interrupt channels 0/1 detection	○	#20	14 _H	FFFFAC _H			
DTTI0	Δ						
Output compare channel 4 match	○	#21	15 _H	FFFFA8 _H	ICR05	0000B5 _H ^{*2}	
DTP/ext. interrupt channels 2/3 detection	○	#22	16 _H	FFFFA4 _H			
DTTI1	Δ						
Output compare channel 5 match	○	#23	17 _H	FFFFA0 _H	ICR06	0000B6 _H ^{*1}	
End of measurement by PWC1 timer / PWC1 timer overflow	○	#24	18 _H	FFFF9C _H			
DTP/ext. interrupt channels 4/5 detection	○	#25	19 _H	FFFF98 _H	ICR07	0000B7 _H ^{*1}	
Waveform sequencer timer compare match / write timing	○	#26	1A _H	FFFF94 _H			
DTP/ext. interrupt channels 6/7 detection	○	#27	1B _H	FFFF90 _H	ICR08	0000B8 _H ^{*1}	
Waveform sequencer position detect / compare interrupt	○	#28	1C _H	FFFF8C _H			
Waveform generator 16-bit timer 0/1/2 underflow	Δ	#29	1D _H	FFFF88 _H	ICR09	0000B9 _H ^{*1}	
16-bit reload timer 0 underflow	○	#30	1E _H	FFFF84 _H			
16-bit free-running timer zero detect	Δ	#31	1F _H	FFFF80 _H	ICR10	0000BA _H ^{*1}	
16-bit PPG timer 2	○	#32	20 _H	FFFF7C _H			
Input capture channels 0/1	○	#33	21 _H	FFFF78 _H	ICR11	0000BB _H ^{*1}	
16-bit free-running timer compare clear	Δ	#34	22 _H	FFFF74 _H			

(Continued)

(Continued)

Interrupt cause	EI ² OS support	Interrupt vector		Interrupt control register		Priority ^{*2}
		Number	Address	ICR	Address	
Input capture channels 2/3	○	#35	23 _H	FFFF70 _H	ICR12	0000BC _H ^{*1}
Timebase timer	Δ	#36	24 _H	FFFF6C _H		
UART1 receive	◎	#37	25 _H	FFFF68 _H	ICR13	0000BD _H ^{*1}
UART1 send	Δ	#38	26 _H	FFFF64 _H		
UART0 receive	◎	#39	27 _H	FFFF60 _H	ICR14	0000BE _H ^{*1}
UART0 send	Δ	#40	28 _H	FFFF5C _H		
Flash memory status	Δ	#41	29 _H	FFFF58 _H	ICR15	0000BF _H ^{*1}
Delayed interrupt generator module	Δ	#42	2A _H	FFFF54 _H		

◎ : Can be used and support the EI²OS stop request.

○ : Can be used and interrupt request flag is cleared by EI²OS interrupt clear signal.

× : Cannot be used.

Δ : Usable when an interrupt cause that shares the ICR is not used.

■ PERIPHERAL RESOURCES

1. Low-Power Consumption Control Circuit

The MB90460 series has the following CPU operating mode configured by selection of an operating clock and clock operation control.

- Clock mode

PLL clock mode : A PLL clock that is a multiple of the oscillation clock (HCLK) frequency is used to operate the CPU and peripheral functions.

Main clock mode : The main clock, with a frequency one-half that of the oscillation clock (HCLK) , is used to operate the CPU and peripheral functions. In main clock mode, the PLL multiplier circuit is inactive.

- CPU intermittent operation mode

CPU intermittent operation mode causes the CPU to operate intermittently, while high-speed clock pulses are supplied to peripheral functions, reducing power consumption. In CPU intermittent operation mode, intermittent clock pulses are only applied to the CPU when it is accessing a register, internal memory, a peripheral function, or an external unit.

- Standby mode

In standby mode, the low power consumption control circuit stops supplying the clock to the CPU (sleep mode) or the CPU and peripheral functions (timebase timer mode) , or stops the oscillation clock itself (stop mode) , reducing power consumption.

- PLL sleep mode

PLL sleep mode is activated to stop the CPU operating clock when the microcontroller enters PLL clock mode; other components continue to operate on the PLL clock.

- Main sleep mode

Main sleep mode is activated to stop the CPU operating clock when the microcontroller enters main clock mode; other components continue to operate on the main clock.

- PLL timebase timer mode

PLL timebase timer mode causes microcontroller operation, with the exception of the oscillation clock, PLL clock and timebase timer, to stop. All functions other than the timebase timer are deactivated.

- Main timebase timer mode

Main timebase timer mode causes microcontroller operation, with the exception of the oscillation clock, main clock and the timebase timer, to stop. All functions other than the timebase timer are deactivated.

- Stop mode

Stop mode causes the source oscillation to stop. All functions are deactivated.

Block Diagram

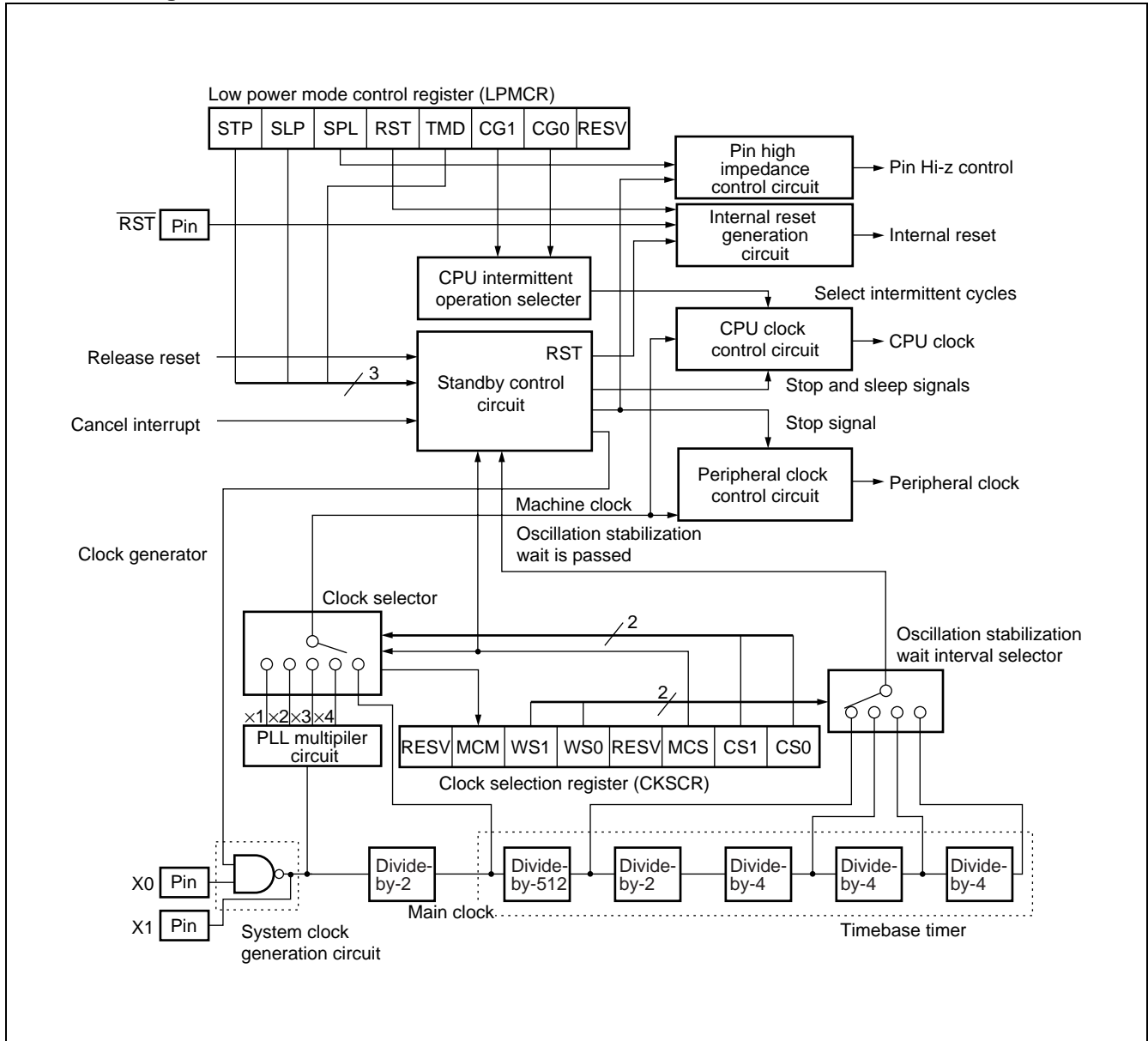

MB90460 Series

2. I/O Ports

(1) Outline of I/O ports

When a data register serving for control output is read, the data output from it as a control output is read regardless of the value in the direction register. Note that, if a read-modify-write instruction (such as a bit set instruction) is used to preset output data in the data register when changing its setting from input to output, the data read is not the data register latched value but the input data from the pin.

Ports 0 to 4 and 6 are input/output ports which serve as inputs when the direction register value is "0" or as outputs when the value is "1".

Port 5 are input/output ports as other port when ADER is 00H.

Block Diagram

- Block diagram of Port 0 pins

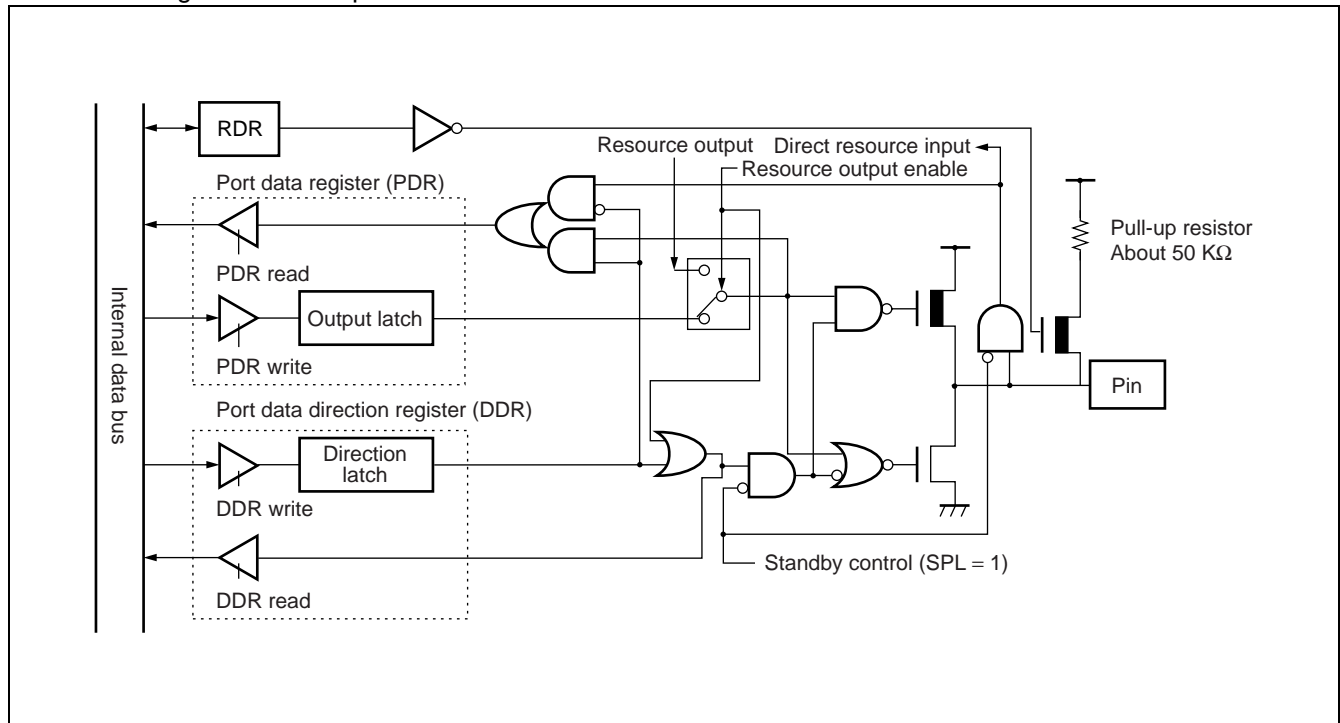

(Continued)

- Block diagram of Port 1 pins

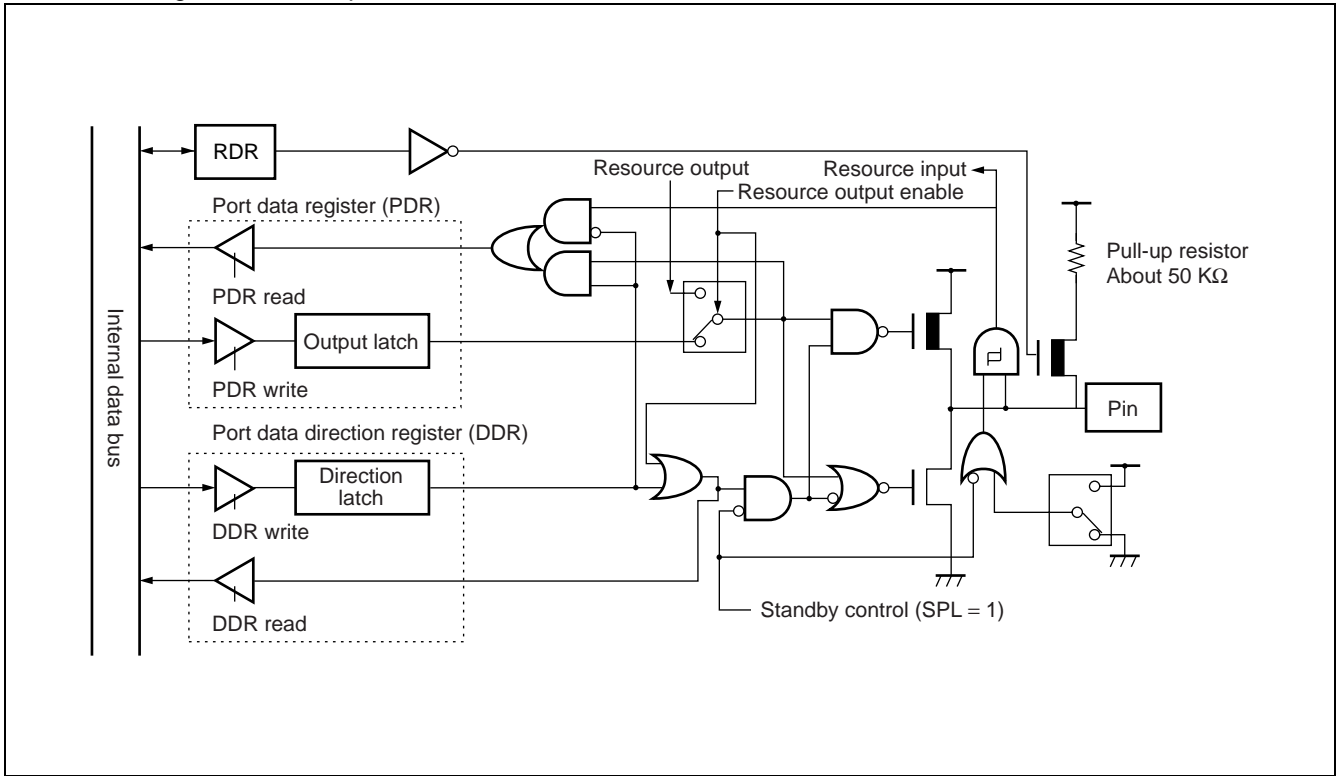

- Block diagram of Port 2 pins

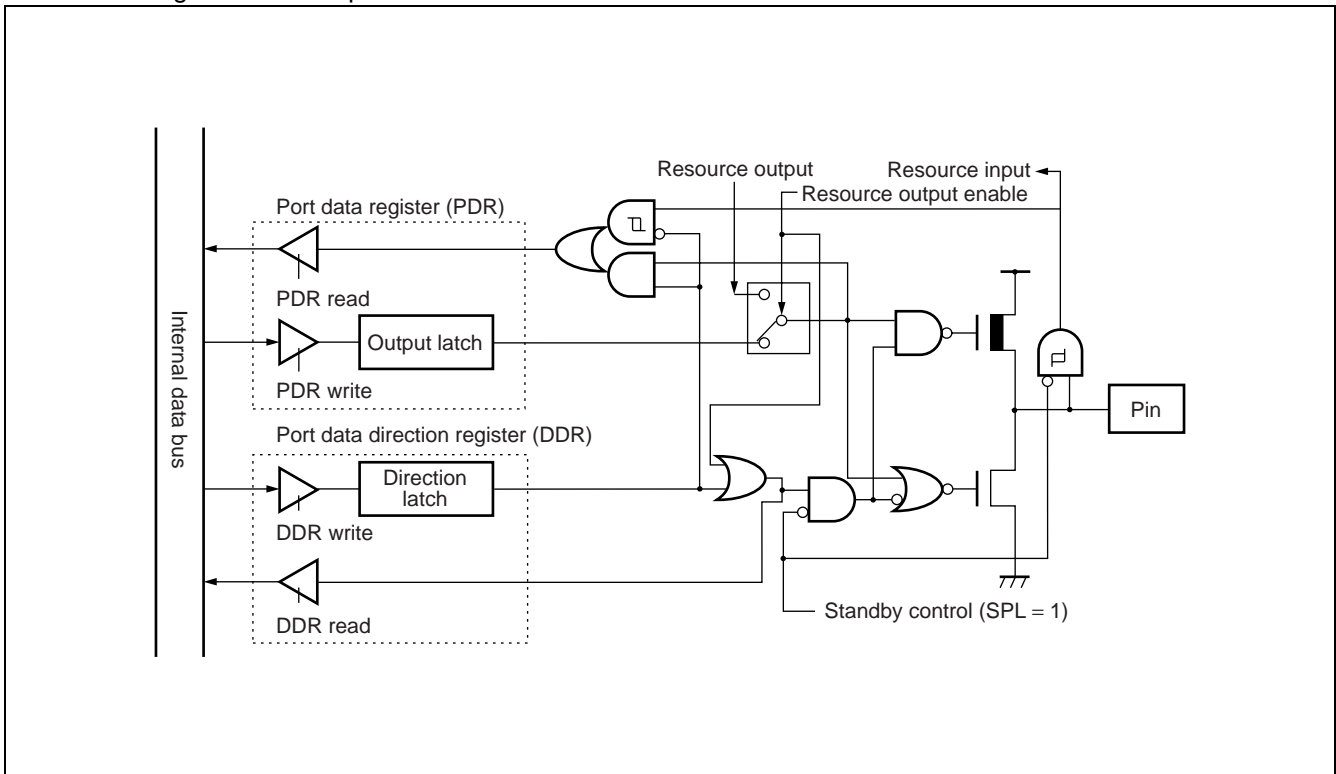

(Continued)

MB90460 Series

- Block diagram of Port 3 pins

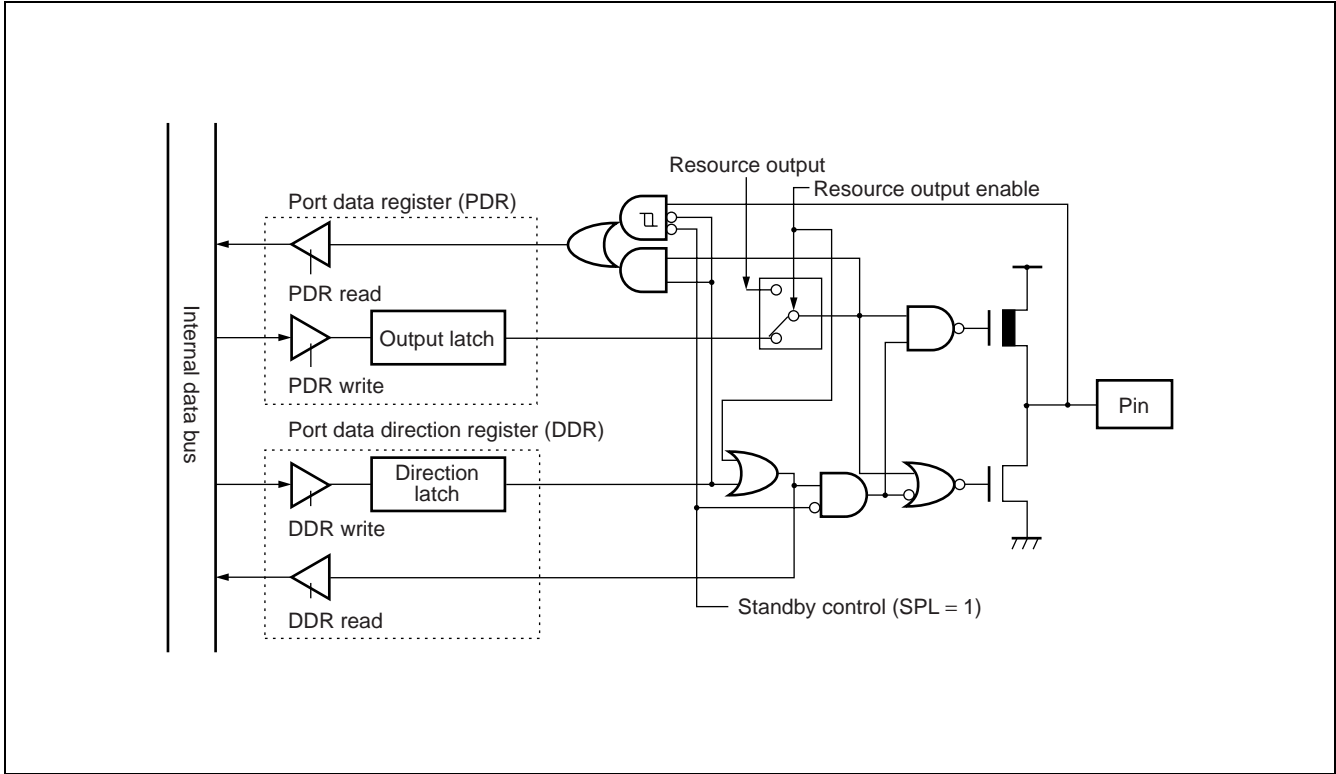

- Block diagram of Port 4 pins

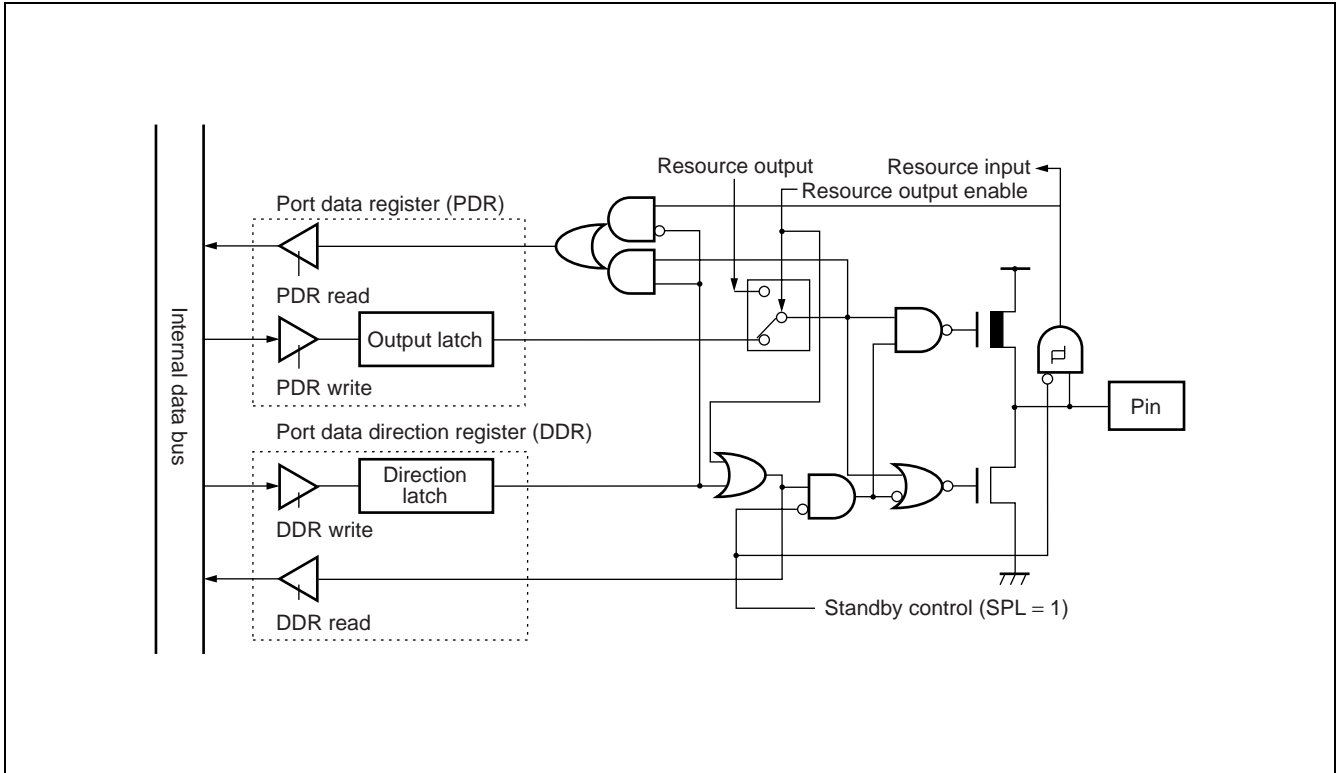

(Continued)

(Continued)

- Block diagram of Port 5 pins

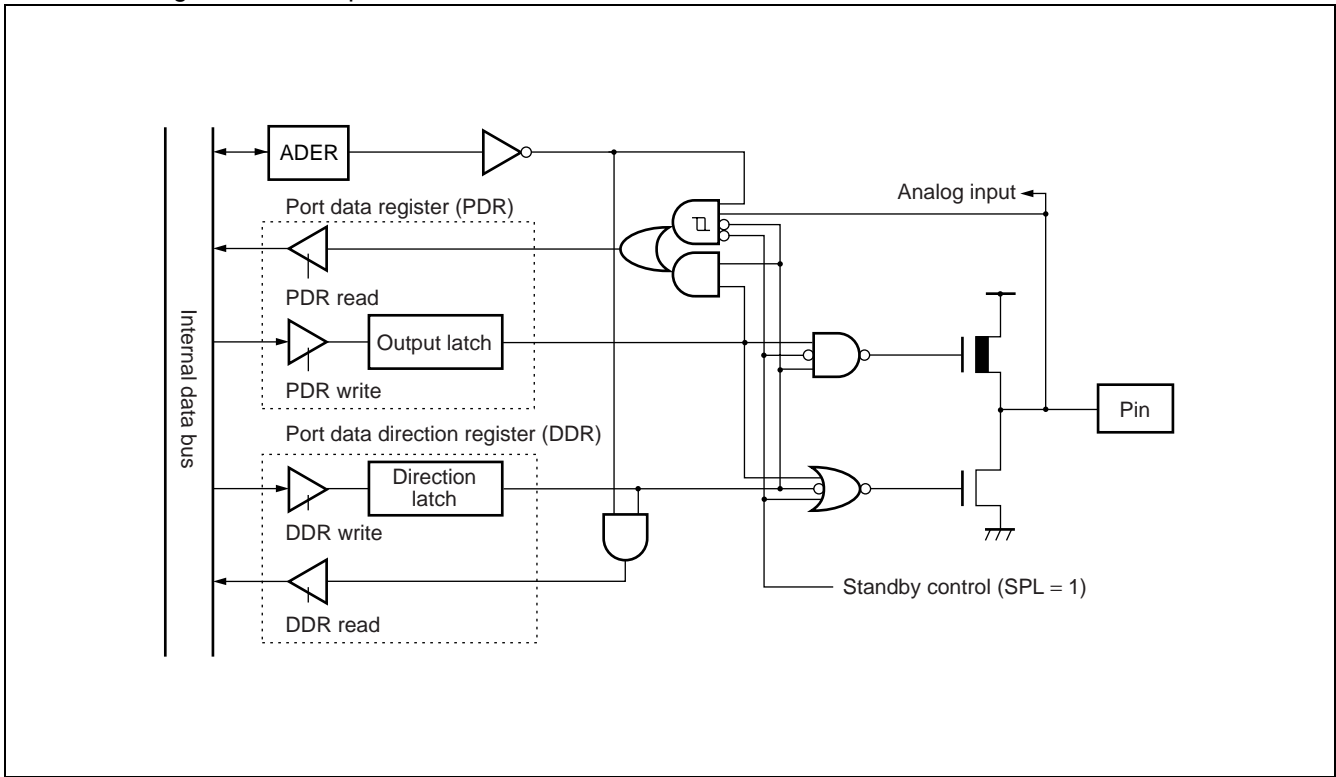

- Block diagram of Port 6 pins

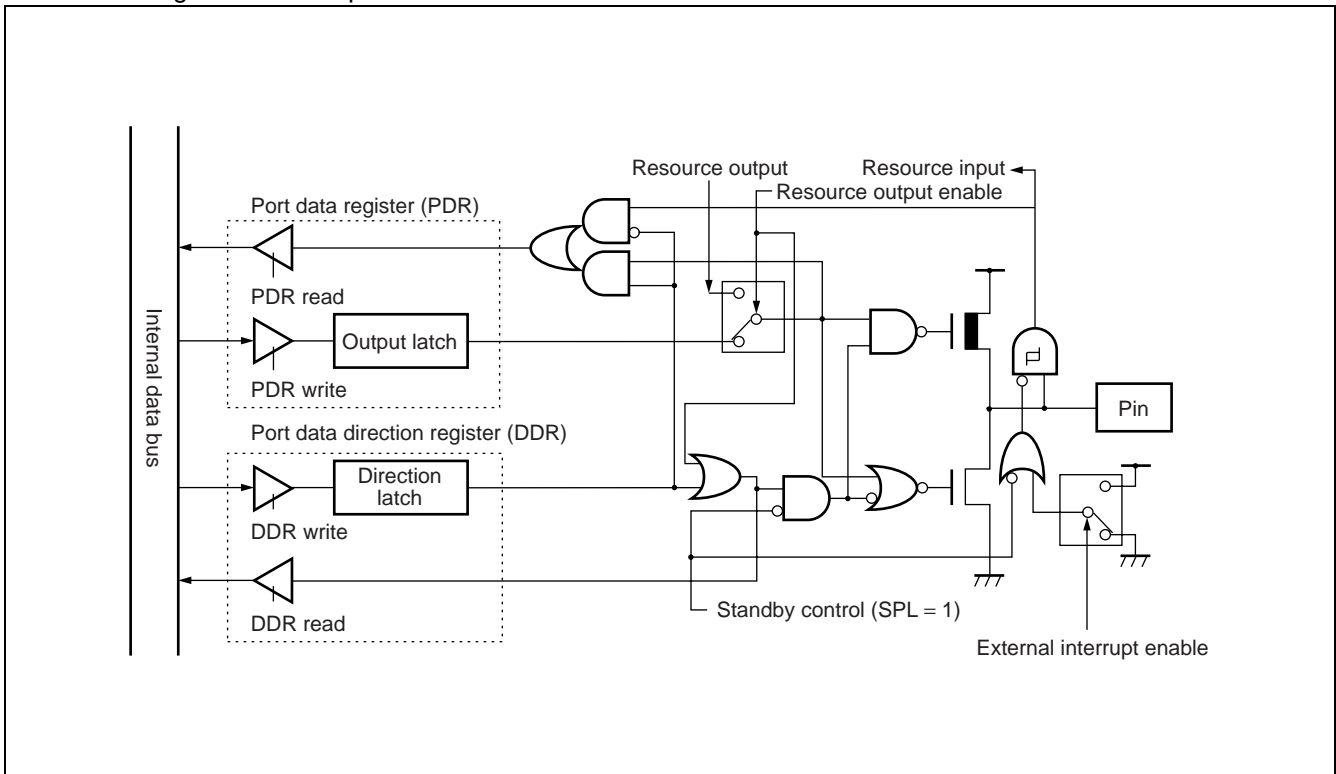

MB90460 Series

3. Timebase Timer

The timebase timer is an 18-bit free-running counter (timebase counter) that counts up in synchronization to the internal count clock (main oscillator clock divided by 2) .

Features of timebase timer :

- Interrupt generated when counter overflow
- EI²OS supported
- Interval timer function :
An interrupt generated at four different time intervals
- Clock supply function :
Four different clocks can be selected as a watchdog timer's count clock
Supply clock for oscillation stabilization

Block Diagram

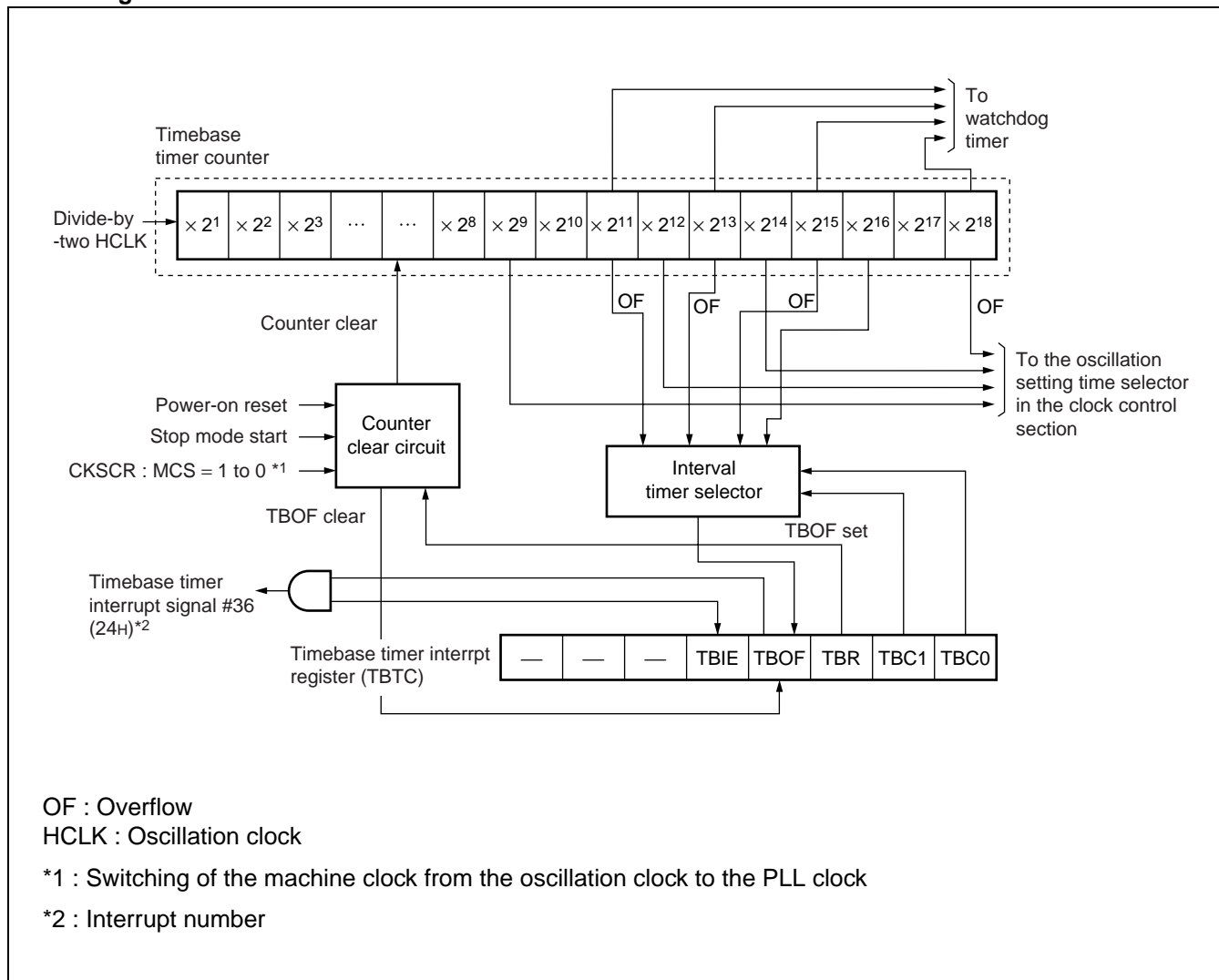

4. Watchdog Timer

The watchdog timer is a 2-bit counter that uses the timebase timer's supply clock as the count clock. After activation, if the watchdog timer is not cleared within a given period, the CPU will be reset.

- Features of Watchdog Timer :
 - Reset CPU at four different time intervals
 - Status bits to indicate the reset causes

Block Diagram

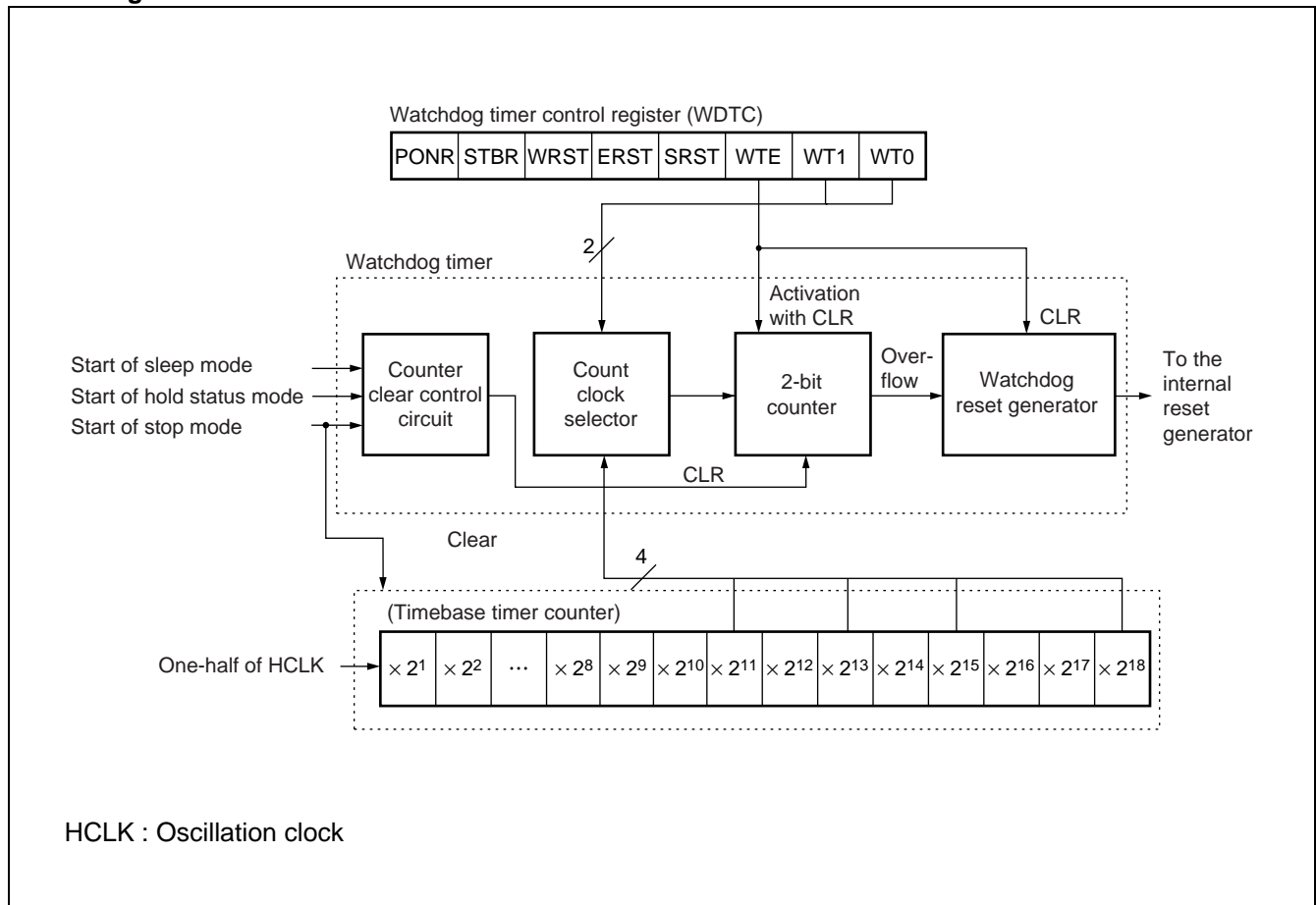

5. 16 bit reload timer (× 2)

The 16-bit reload timer provides two operating mode, internal clock mode and event count mode. In each operating mode, the 16-bit down counter can be reloaded (reload mode) or stopped when underflow (one-shot mode) .

Output pins TO1 - TO0 are able to output different waveform according to the counter operating mode. TO1 - TO0 toggles when counter underflow if counter is operated as reload mode. TO1 - TO0 output specified level (H or L) when counter is counting if the counter is in one-shot mode.

Features of the 16 bit reload timer :

- Interrupt generated when timer underflow
- EI²OS supported
- Internal clock operating mode :
 - Three internal count clocks can be selected
 - Counter can be activated by software or external trigger (signal at TIN1 - TIN0 pin)
 - Counter can be reloaded or stopped when underflow after activated
- Event count operating mode :
 - Counter counts down by one when specified edge at TIN1 - TIN0 pin
 - Counter can be reloaded or stopped when underflow

Block Diagram

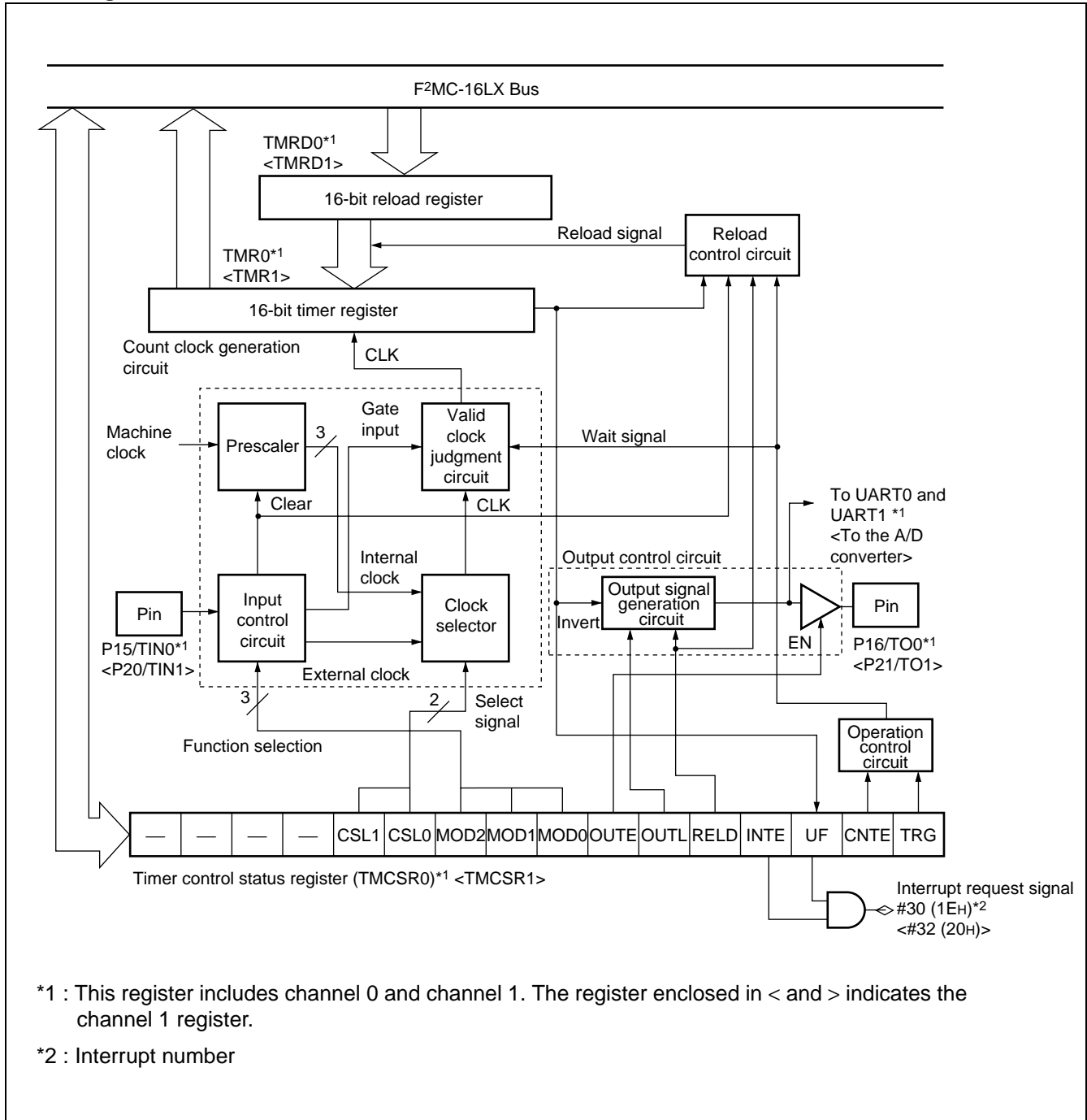

*1 : This register includes channel 0 and channel 1. The register enclosed in < and > indicates the channel 1 register.

*2 : Interrupt number

MB90460 Series

6. 16-bit PPG Timer (× 3)

The 16-bit PPG timer consists of a 16-bit down counter, prescaler, 16-bit period setting buffer register, 16-bit duty setting buffer register, 16-bit control register and a PPG output pin. This module can be used to output pulses synchronized by software trigger or GATE signal from Multi-functional timer, refer to "Multi-functional Timer"

Features of 16-bit PPG Timer :

- Two operating mode : PWM and One-shot
- 8 types of counter operation clock (ϕ , $\phi/2$, $\phi/4$, $\phi/8$, $\phi/16$, $\phi/32$, $\phi/64$, $\phi/128$) can be selected
- Interrupt generated when trigger signal arrived, or counter borrow, or change of PPG output
- EI²OS supported

Block Diagram

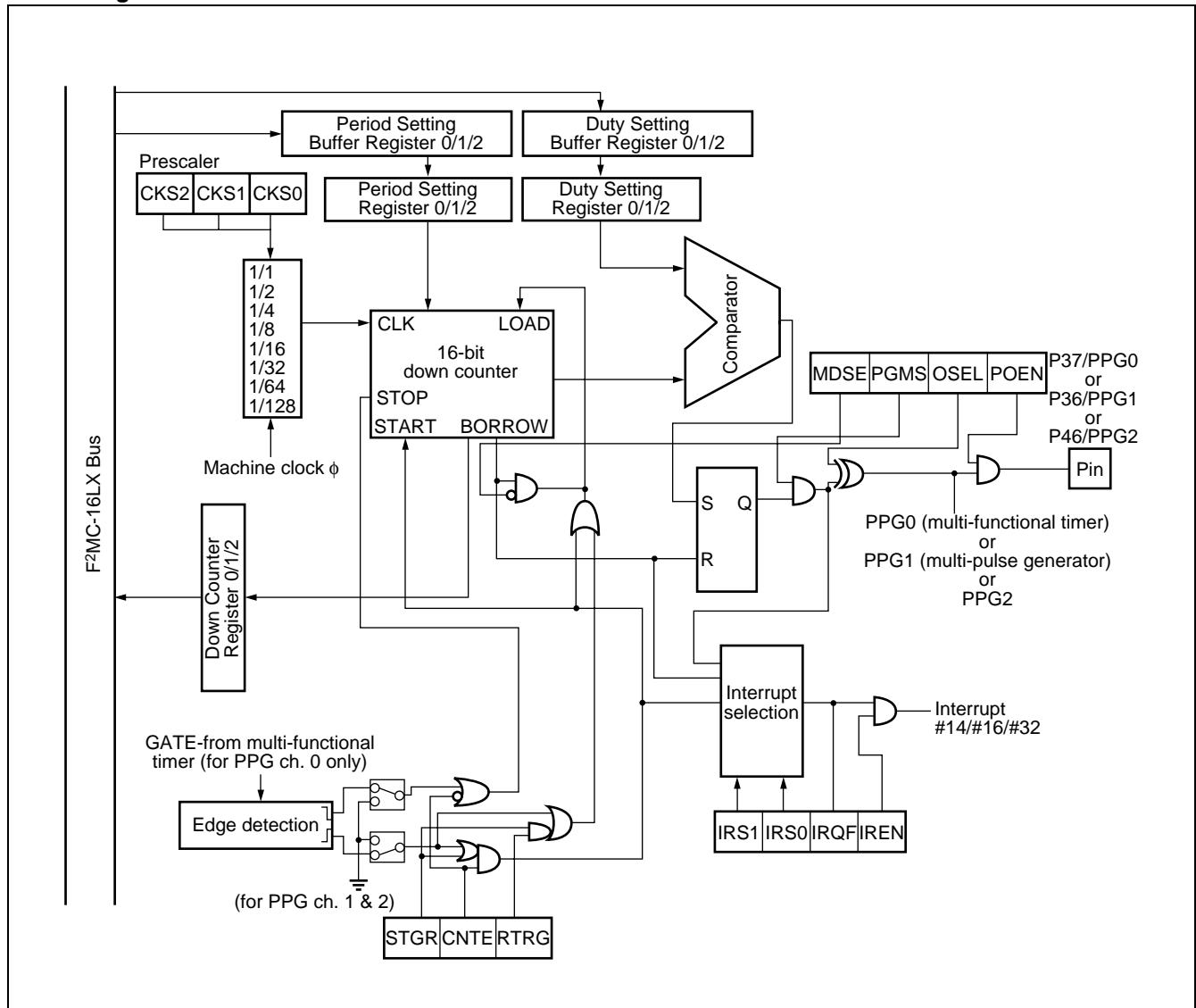

7. Multi-functional Timer

The 16-bit multi-functional timer module consists of one 16-bit free-running timer, four input capture circuits, six output comparators and one channel of 16-bit PPG timer. This module allows six independent waveforms generated by PPG timer or waveform generator to be outputted. With the 16-bit free-run timer and the input capture circuit, a input pulse width measurement and external clock cycle measurement can be done.

(1) 16-bit free-running timer (1 channel)

- The 16-bit free-running timer consists of a 16-bit up/up-down counter, control register, 16-bit compare clear register (with buffer register) and a prescaler.
- 8 types of counter operation clock (ϕ , $\phi/2$, $\phi/4$, $\phi/8$, $\phi/16$, $\phi/32$, $\phi/64$, $\phi/128$) can be selected. (ϕ is the machine clock)
- Two types of interrupt causes :
 - Compare clear interrupt is generated when there is a comparing match with compare clear register and 16-bit free-run timer.
 - Zero detection interrupt is generated while 16-bit free-running timer is detected as zero in count value.
- EI²OS supported
- The compare clear register has a selectable buffer register, into which data is written for transfer to the compare clear register. When the timer is stopped, transfer occurs immediately when the data is written to the buffer. When the timer is operation, data transfer from the buffer occurs when the timer value is detected to be zero.
- Reset, software clear, compare match with compare clear register in up-count mode will reset the counter value to "0000H".
- Supply clock to output compare module :
The prescaler output is acted as the count clock of the output compare.

(2) Output compare module (6 channels)

- The output compare module consists of six 16-bit compare registers (with selectable buffer register) , compare output latch and compare control registers. An interrupt is generated and output level is inverted when the value of 16-bit free-running timer and compare register are matched.
- 6 compare registers can be operated independently.
- Output pins and interrupt flag are corresponding to each compare register.
- Inverts output pins by using 2 compare registers together. 2 compare registers can be paired to control the output pins.
- Setting the initial value for each output pin is possible.
- Interrupt generated when there is a comparing match with output compare register and 16 bit free-run timer
- EI²OS supported

(3) Input capture module (4 channels)

Input capture consists of 4 independent external input pins, the corresponding capture register and capture control register. By detecting any edge of the input signal from the external pin, the value of the 16-bit free-running timer can be stored in the capture register and an interrupt is generated simultaneously.

- Operation synchronized with the 16-bit free-run timer's count clock.
- 3 types of trigger edge (rising edge, falling edge and both edge) of the external input signal can be selected and there is indication bit to show the trigger edge is rising or falling.
- 4 input captures can be operated independently.
- Two independent interrupts are generated when detecting a valid edge from external input.
- EI²OS supported

(4) 16-bit PPG timer (× 1)

The 16-bit PPG timer 0 is used to provide a PPG signal for waveform generator.

MB90460 Series

(5) Waveform Generator module

The waveform generator consists of three 16-bit timer registers, three timer control registers and 16-bit waveform control register.

With waveform generator, it is possible to generate real time output, 16-bit PPG waveform output, non-overlap 3-phase waveform output for inverter control and DC chopper waveform output.

- It is possible to generate a non-overlap waveform output based on dead-time of 16-bit timer. (Dead-time timer function)
- It is possible to generate a non-overlap waveform output when realtime output is operated in 2-channel mode. (Dead-time timer function)
- By detecting realtime output compare match, GATE signal of the PPG timer operation will be generated to start or stop PPG timer operation. (GATE function)
- When a match is detected by realtime output compare, the 16-bit timer is activated. The PPG timer can be started or stopped easily by generating a GATE signal for PPG operation until the 16-bit timer stops. (GATE function)
- Forced to stop output waveform using DTTI0 pin input
- Interrupt generated when DTTI0 active or 16-bit timer underflow
- EI²OS supported

- MCU to 3-phase Motor Interface Circuit

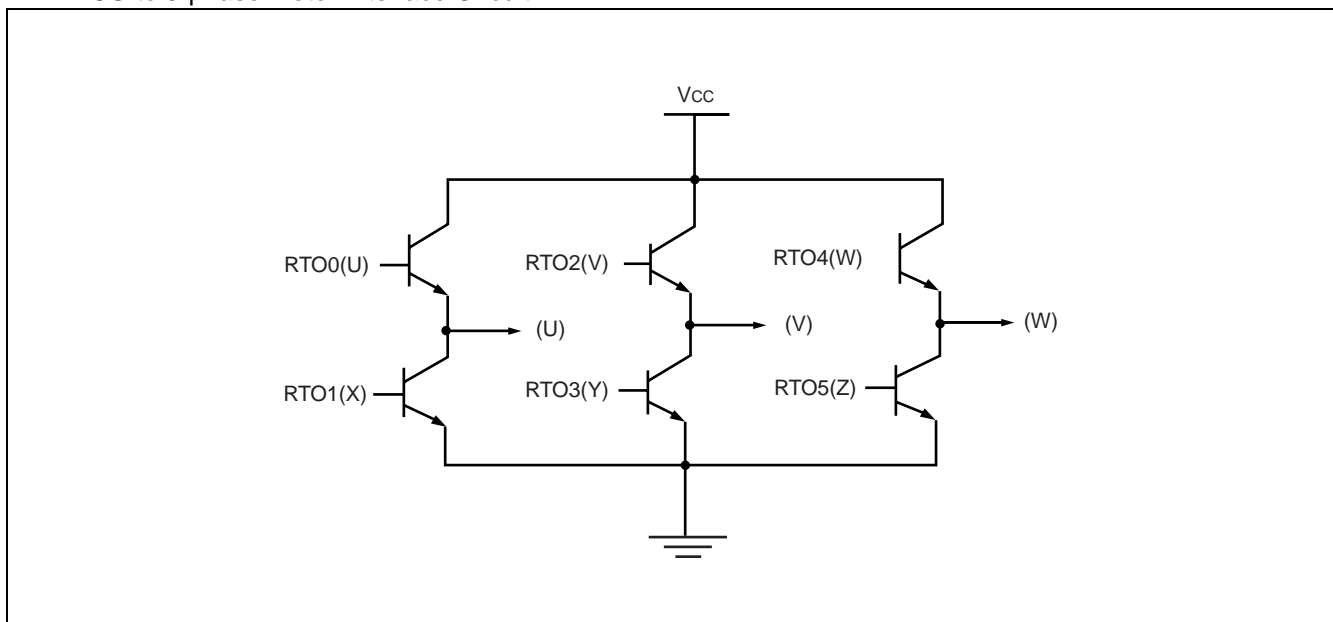

RTO0 (U) , RTO2 (V) , RTO4 (W) are called “UPPER ARM”.

RTO1 (X) , RTO3 (Y) , RTO5 (Z) are called “LOWER ARM”.

RTO0 (U) and RTO1 (X) are called “non-overlapping output pair”.

RTO2 (V) and RTO3 (Y) are called “non-overlapping output pair”.

RTO4 (W) and RTO5 (Z) are called “non-overlapping output pair”.

(U) , (V) , (W) are the 3-phase coil connection.

- 3-phase Motor Coil Connection Circuit

Star Connection Circuit

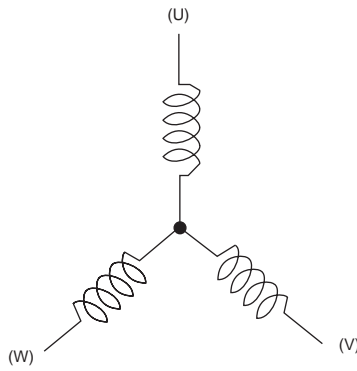

Delta Connection Circuit

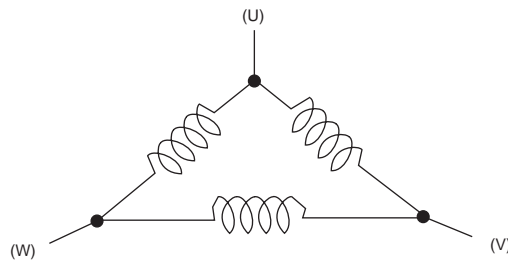

MB90460 Series

Block Diagram

- Block Diagram of Multi-functional Timer

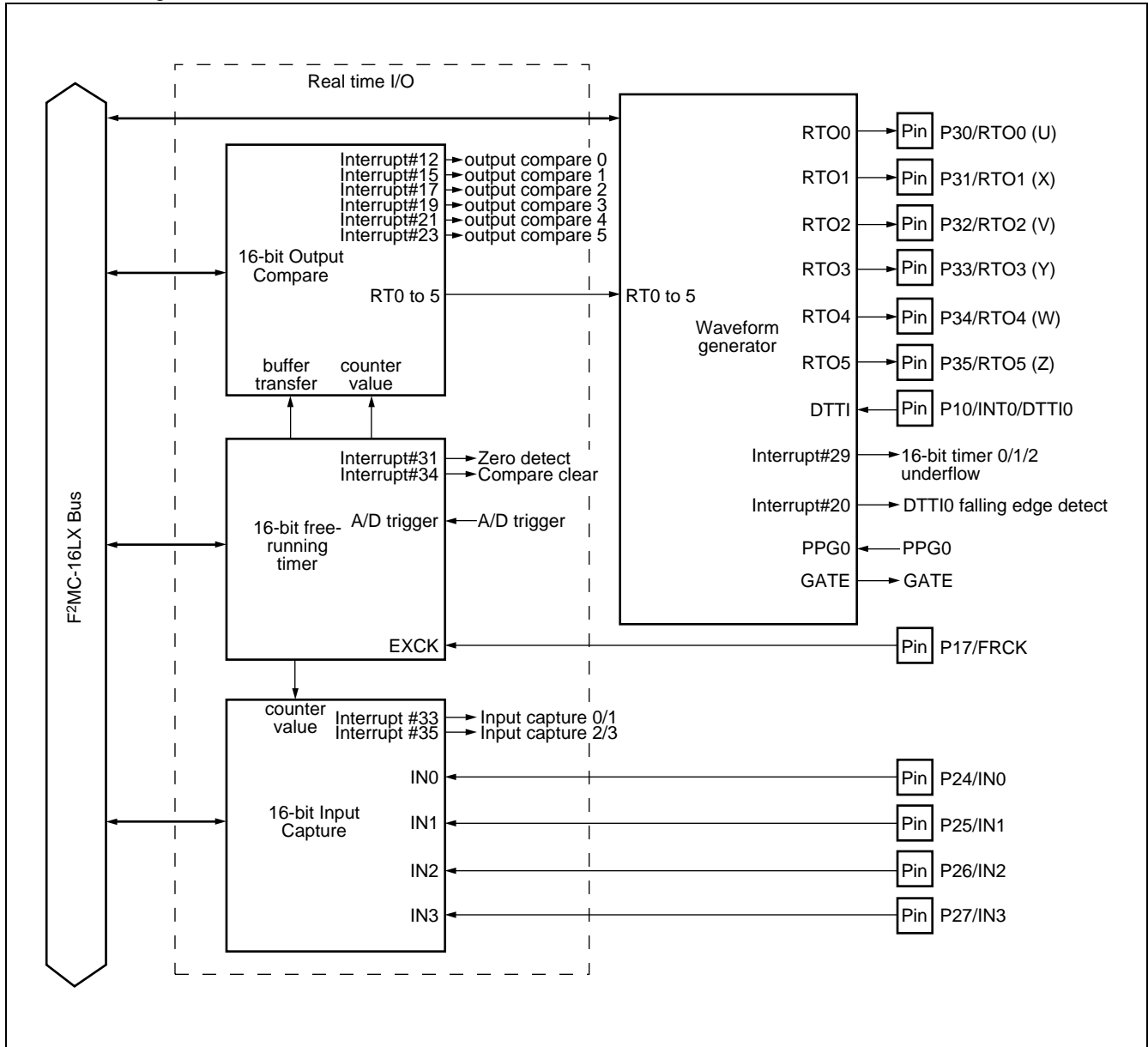

(Continued)

• Block diagram of 16-bit free-running timer

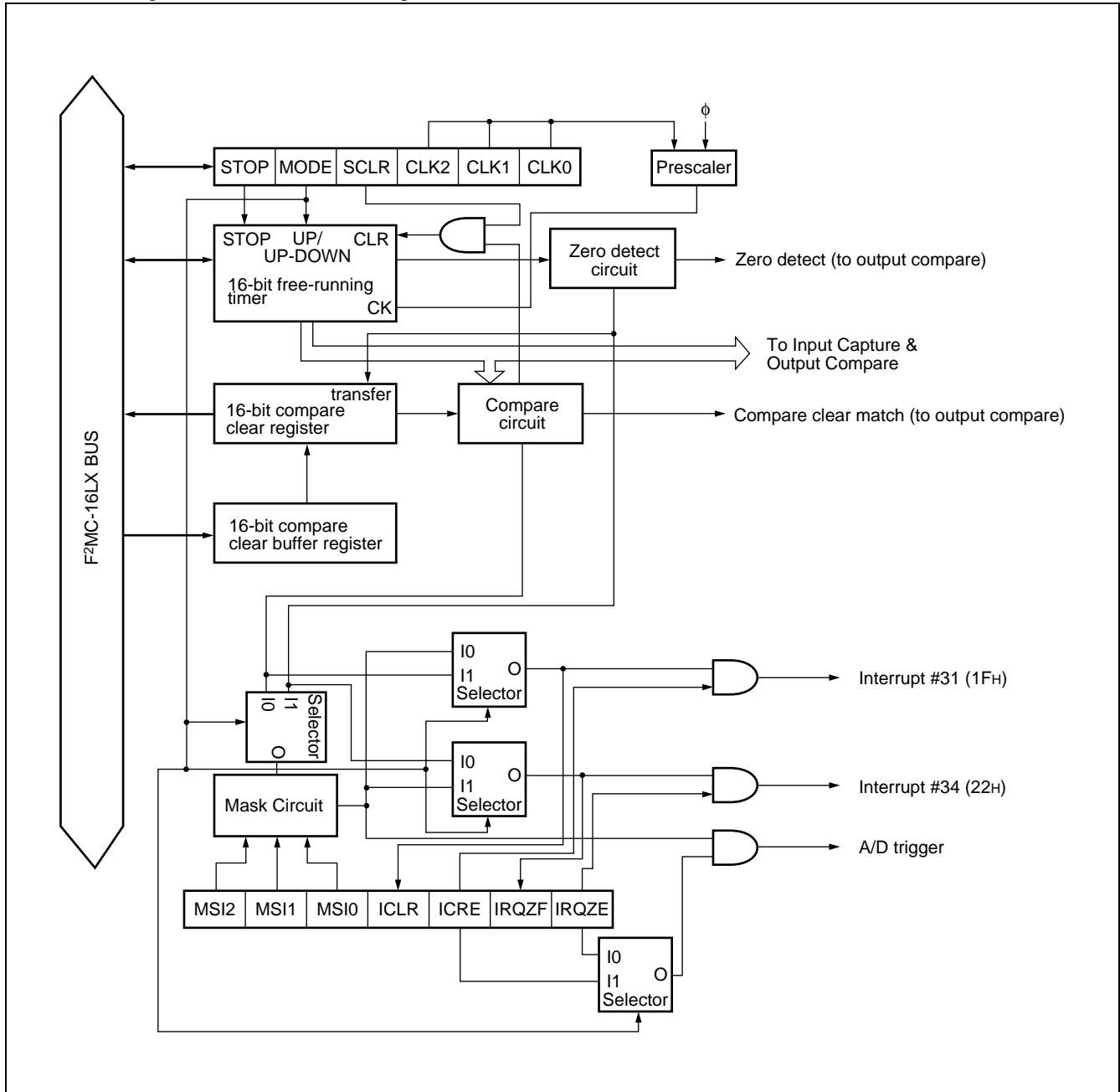

(Continued)

(Continued)

- Block diagram of waveform generator

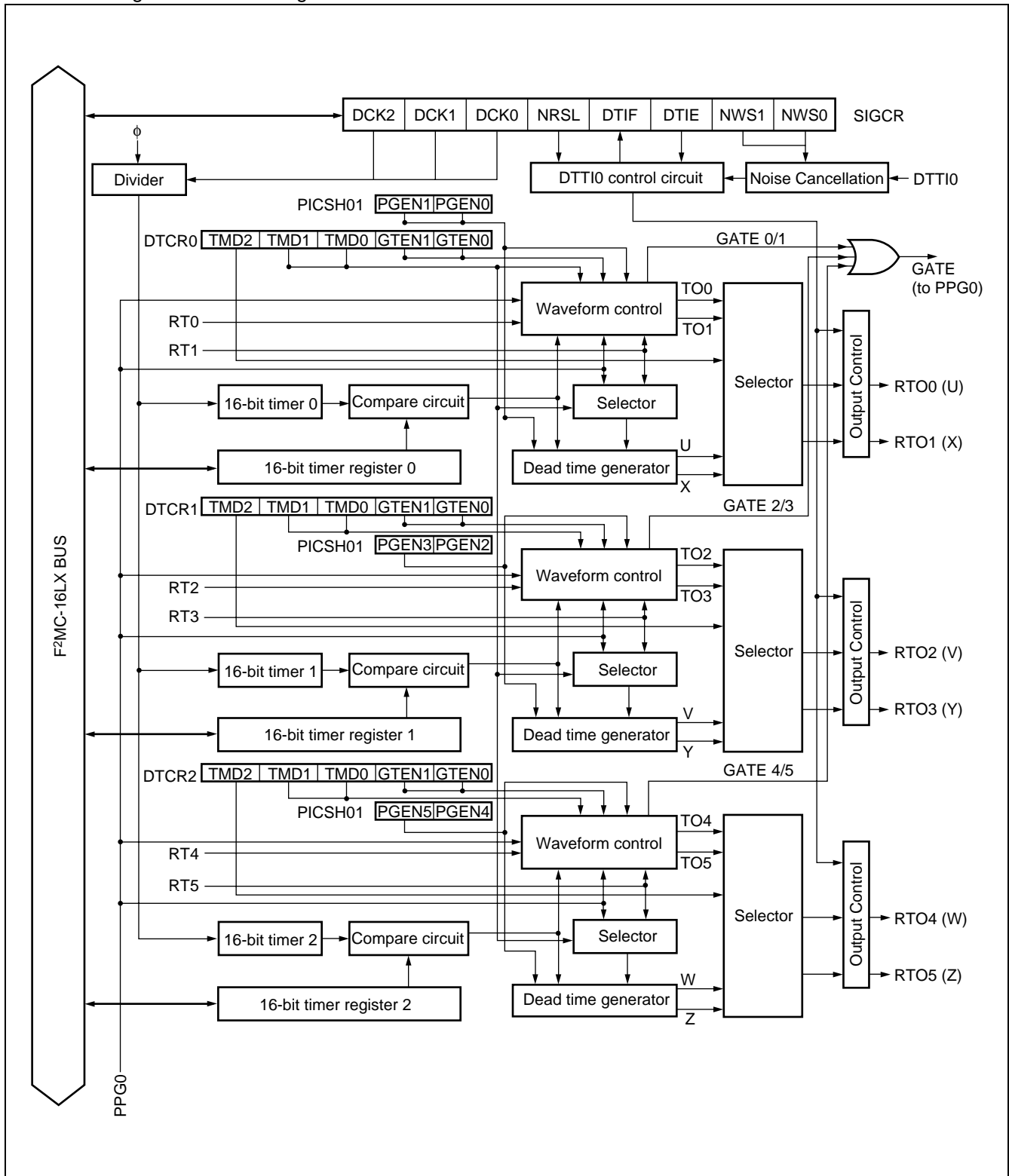

8. Multi-Pulse Generator

The Multi-pulse Generator consists of a 16-bit PPG timer, a 16-bit reload timer and a waveform sequencer. By using the waveform sequencer, 16-bit PPG timer output signal can be directed to Multi-pulse Generator output (OPT5 to 0) according to the input signal of Multi-pulse Generator (SNI2 to 0). Meanwhile, the OPT5 to 0 output signal can be hardware terminated by DTTI input (DTTI1) in case of emergency. The OPT5 to 0 output signals are synchronized with the PPG signal in order to eliminate the unwanted glitch.

The Multi-pulse generator has the following features :

- Output Signal Control
 - 12 output data buffer registers are provided
 - Output data register can be updated by any one of output data buffer registers when :
 1. an effective edge detected at SNI2 - SNI0 pin
 2. 16-bit reload timer underflow
 3. output data buffer register OPDBR0 is written
- Output data register (OPDR) determines which OPT terminals (OPT5 - 0) output the 16-bit PPG waveform
 - Waveform sequencer is provided with a 16-bit timer to measure the speed of motor
 - The 16-bit timer can be used to disable the OPT output when the position detection is missing
- Input Position Detect Control
 - SNI2 - SNI0 input can be used to detect the rotor position
 - A controllable noise filter is provided to the SNI2 - SNI0 input
- PPG Synchronization for Output signal
 - OPT output is able to synchronize the edge of PPG waveform to avoid a short pulse (or glitch) appearance
- Various interrupt generation causes
- EI²OS supported

Block Diagram

- Block diagram of Multi-pulse generator

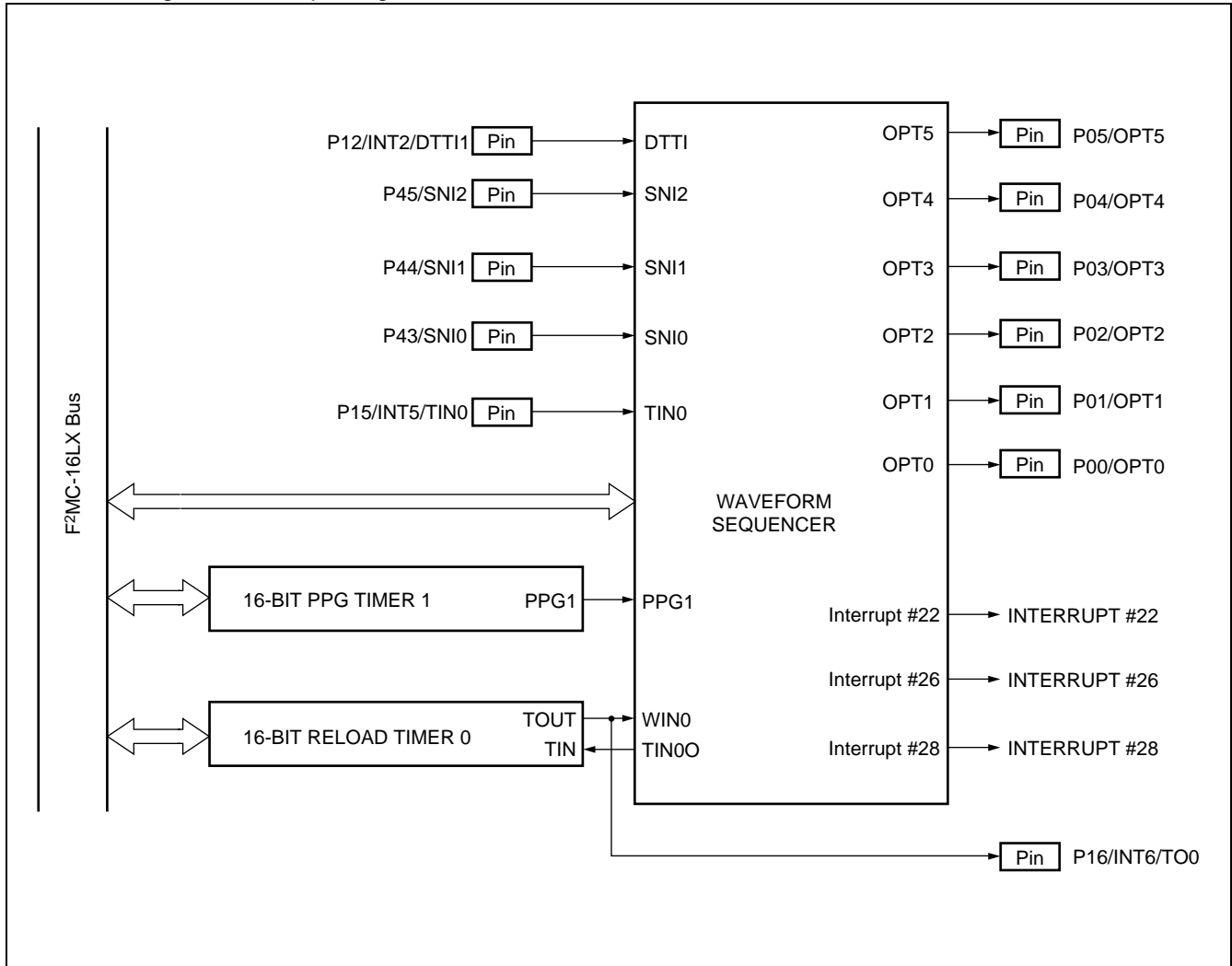

(Continued)

MB90460 Series

(Continued)

- Block diagram of waveform sequencer

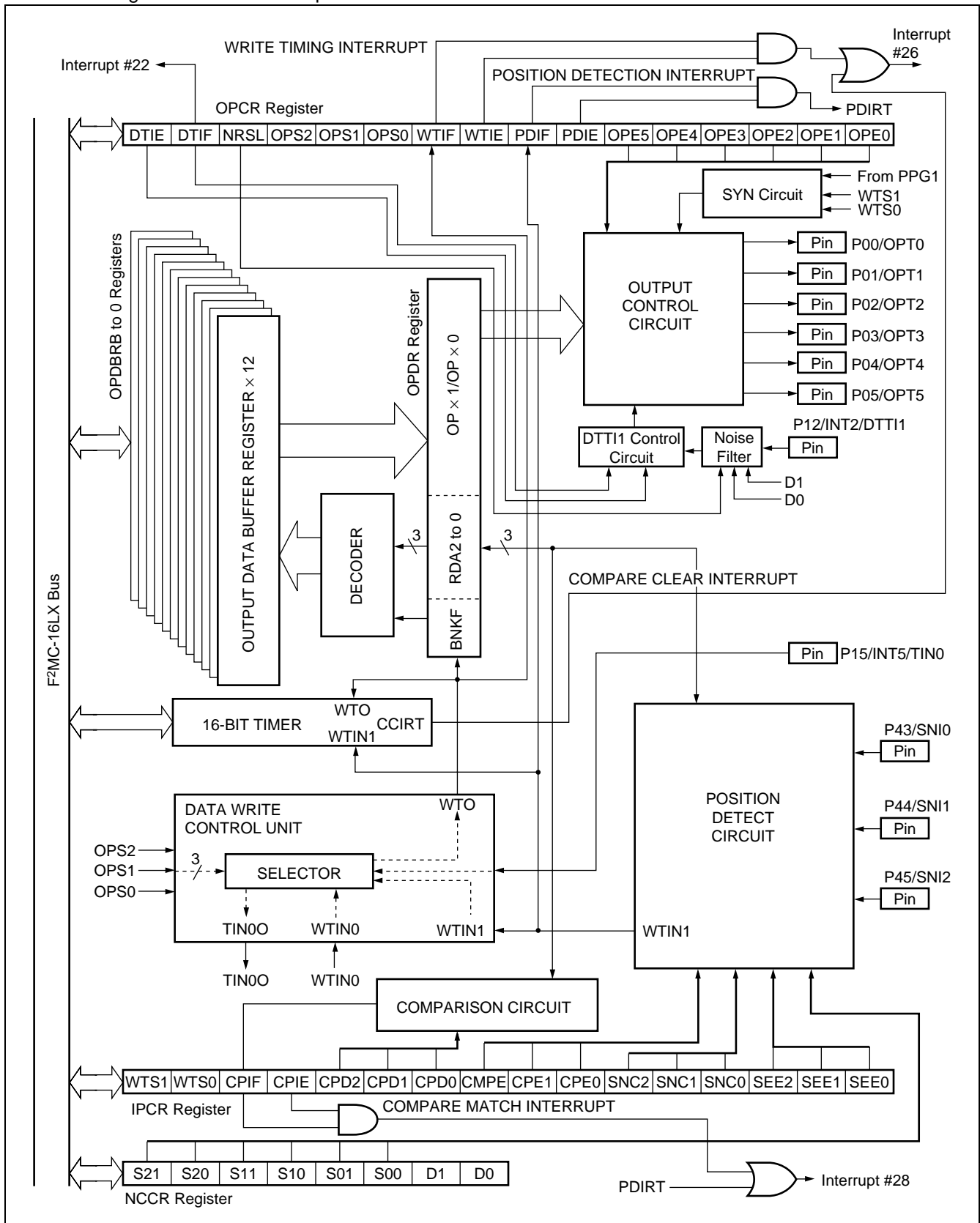

9. PWC Timer

The PWC (pulse width count) timer is a 16-bit multi-function up-counter with reload timer functions and input-signal pulse-width count functions as well.

The PWC timer consists of a 16-bit counter, an input pulse divider, a divide ratio control register, a count input pin, a pulse output pin, and a 16-bit control register.

The PWC timer has the following features :

- Interrupt generated when timer overflow or end of PWC measurement.
- EI²OS supported
- Timer functions :
 - Generates an interrupt request at set time intervals.
 - Outputs pulse signals synchronized with the timer cycle.
 - Selects the counter clock from among three internal clocks.
- Pulse-width count functions
 - Counts the time between external pulse input events.
 - Selects the counter clock from among three internal clocks.
 - Count mode
 - H pulse width (rising edge to falling edge) /L pulse width (falling edge to rising edge)
 - Rising-edge cycle (rising edge to falling edge) /Falling-edge cycle (falling edge to rising edge)
 - Count between edges (rising or falling edge to falling or rising edge)

Capable of counting cycles by dividing input pulses by 2^2 , 2^4 , 2^6 , 2^8 using an 8-bit input divider.

Generates an interrupt request upon the completion of count operation.

Selects single or consecutive count operation.

MB90460 Series

Block Diagram

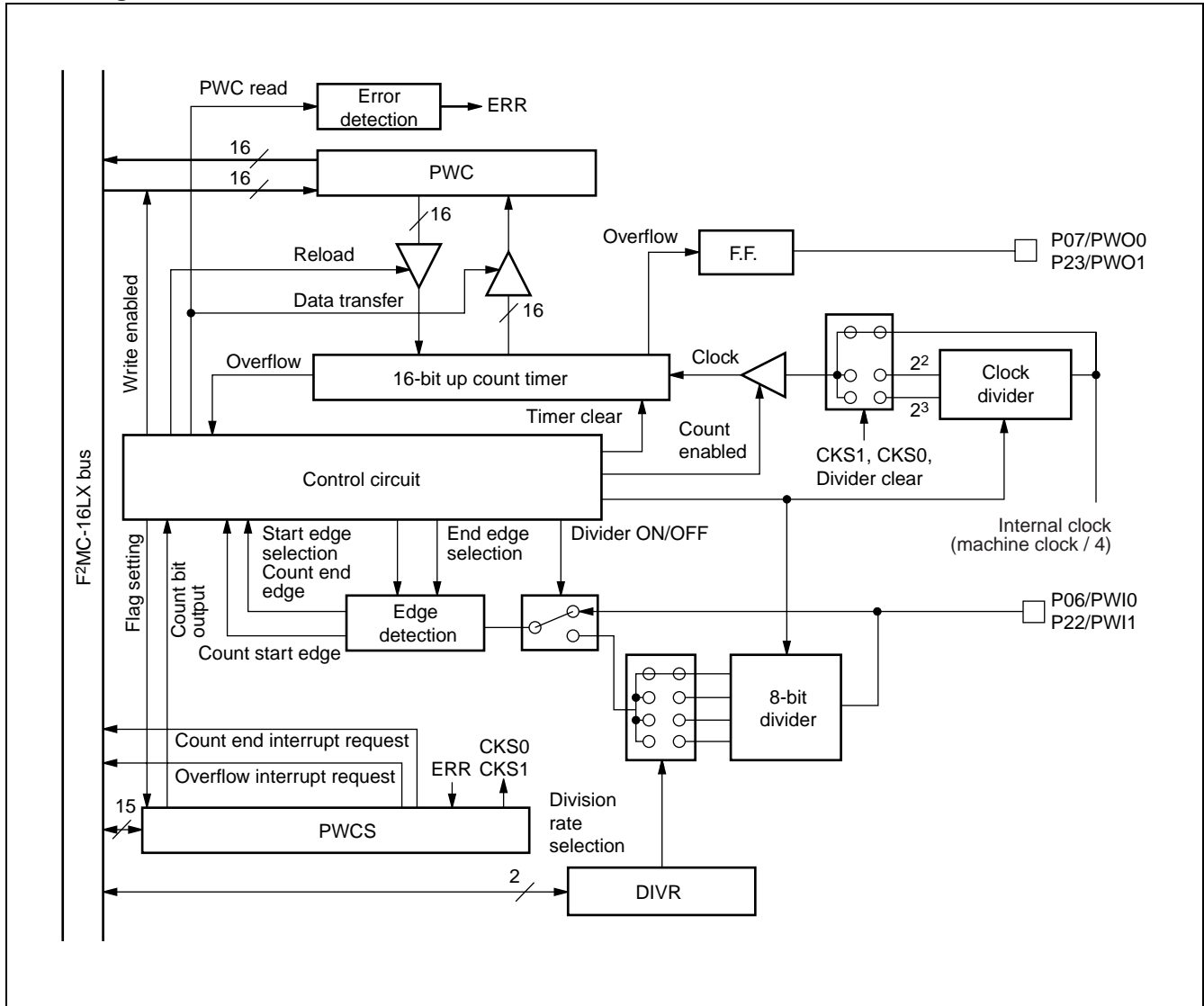

10. UART

The UART is a serial I/O port for asynchronous (start-stop) communication or clock-synchronous communication.

The UART has the following features :

- Full-duplex double buffering
- Capable of asynchronous (start-stop bit) and CLK-synchronous communications
- Support for the multiprocessor mode
- Various method of baud rate generation :
 - External clock input possible
 - Internal clock (a clock supplied from 16-bit reload timer can be used.)
 - Embedded dedicated baud rate generator

Operation	Baud rate
Asynchronous	31250/9615/4808/2404/1202 bps
CLK synchronous	2 M/1 M/500 K/250 K/125 K/62.5 Kbps

* : Assuming internal machine clock frequencies of 6, 8, 10, 12, and 16 MHz

- Error detection functions (parity, framing, overrun)
- NRZ (Non Return to Zero) Signal format
- Interrupt request :
 - Receive interrupt (receive complete, receive error detection)
 - Transmit interrupt (transmission complete)
 - Transmit / receive conforms to extended intelligent I/O service (EI²OS)
- Flexible data length :
 - 7 bit to 9 bit selective (without a parity bit)
 - 6 bit to 8 bit selective (with a parity bit)

MB90460 Series

Block Diagram

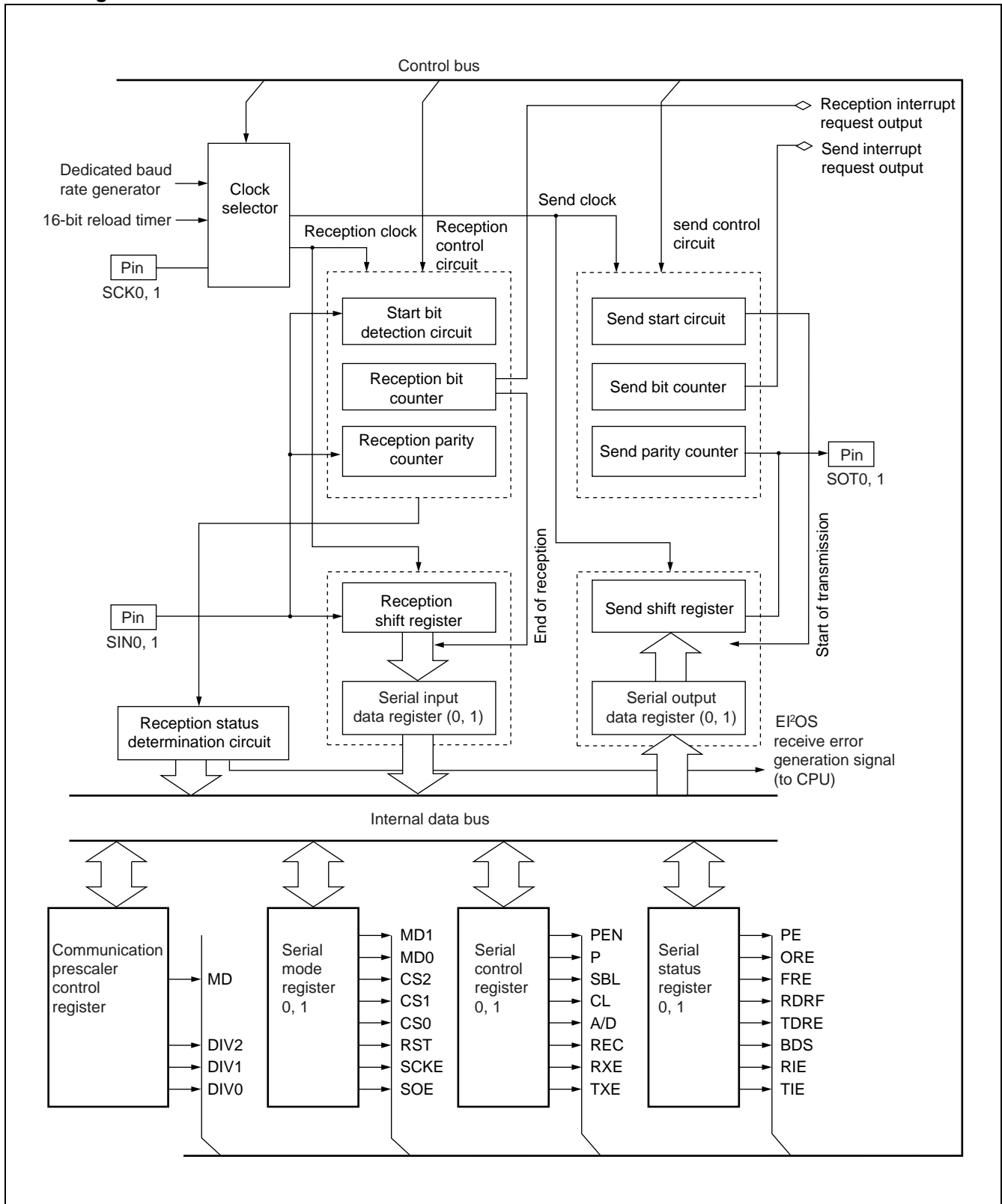

11. DTP/External Interrupts

The DTP/external interrupt circuit is activated by the signal supplied to a DTP/external interrupt pin. The CPU accepts the signal using the same procedure it uses for normal hardware interrupts and generates external interrupts or activates the extended intelligent I/O service (EI²OS) .

Features of DTP/External Interrupt :

- Total 8 external interrupt channels
- Two request levels (“H” and “L”) are provided for the intelligent I/O service.
- Four request levels (rising edge, falling edge, “H” level and “L” level) are provided for external interrupt requests.

Block Diagram

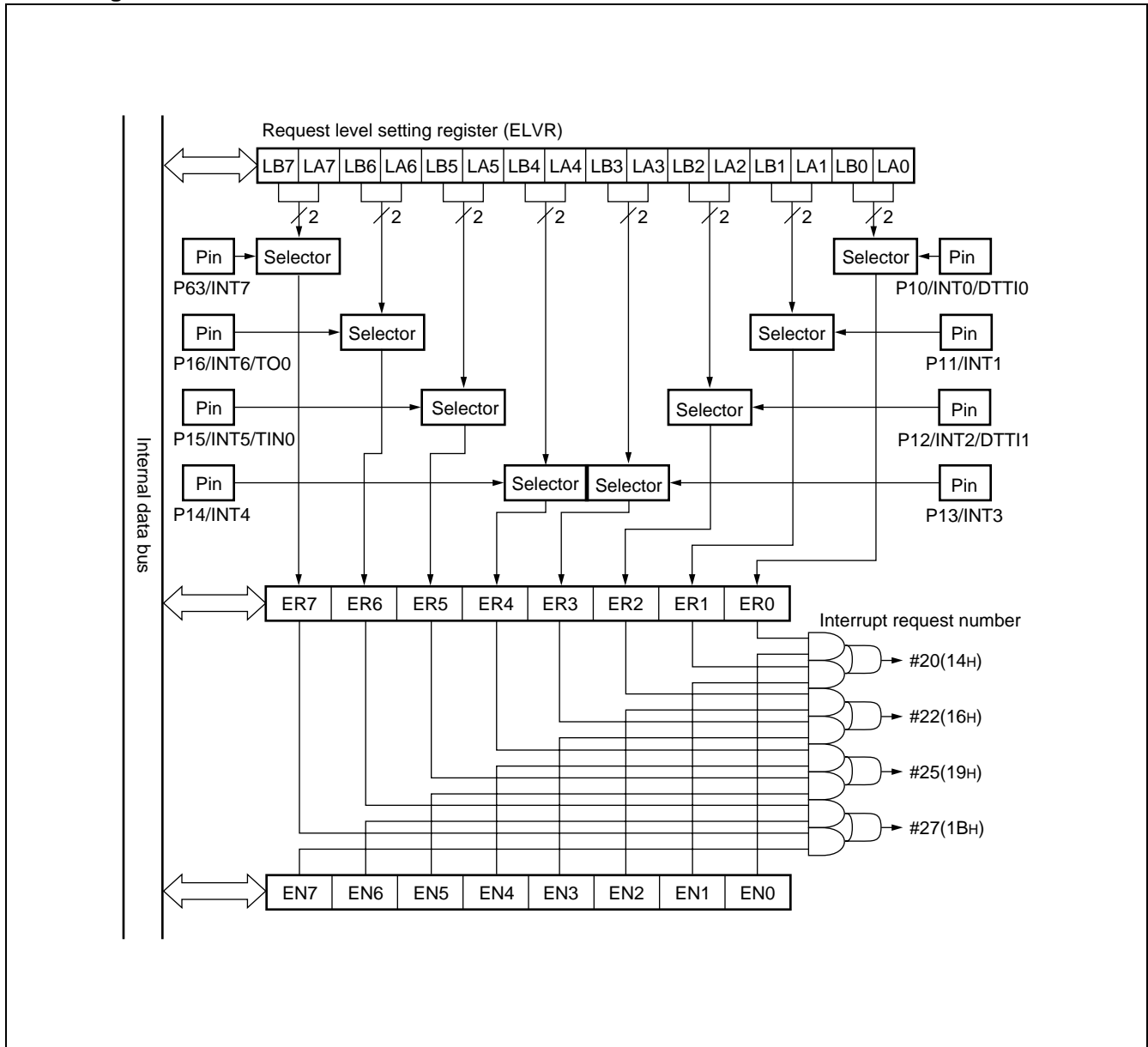

12. Delayed Interrupt Generation Module

The delayed interrupt generation module is used to generate a task switching interrupt. Interrupt requests to the F²MC-16LX CPU can be generated and cleared by software using this module.

Block Diagram

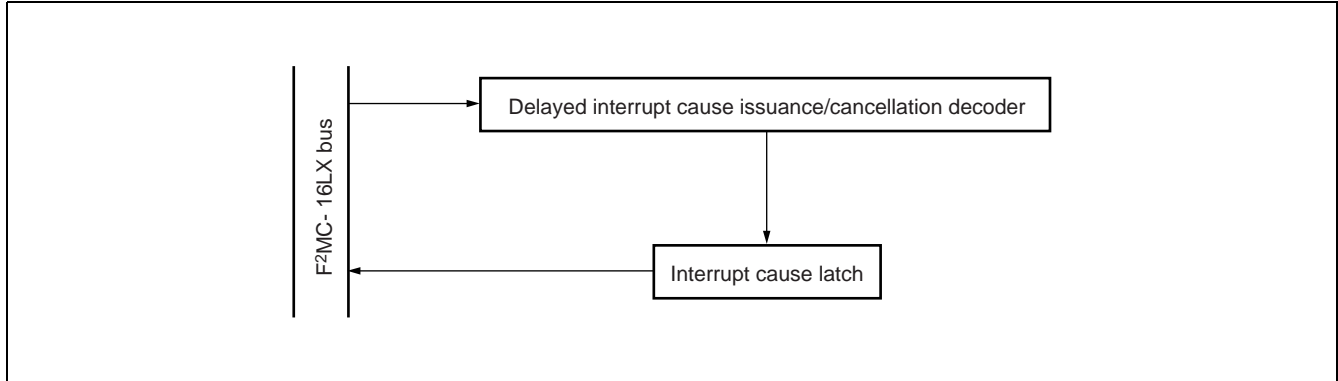

13. A/D Converter

The converter converts the analog voltage input to an analog input pin (input voltage) to a digital value. The converter has the following features :

- The minimum conversion time is 6.13 μs (for a machine clock of 16 MHz; includes the sampling time) .
- The minimum sampling time is 2.0 μs (for a machine clock of 16 MHz) .
- The converter uses the RC-type successive approximation conversion method with a sample hold circuit.
- A resolution of 10 bits or 8 bits can be selected.
- Up to eight channels for analog input pins can be selected by a program.
- Various conversion mode :
 - Single conversion mode : Selectively convert one channel.
 - Scan conversion mode : Continuously convert multiple channels. Maximum of 8 program selectable channels.
 - Continuous conversion mode : Repeatedly convert specified channels.
 - Stop conversion mode : Convert one channel then halt until the next activation. (Enables synchronization of the conversion start timing.)
- At the end of A/D conversion, an interrupt request can be generated and EI²OS can be activated.
- In the interrupt-enabled state, the conversion data protection function prevents any part of the data from being lost through continuous conversion.
- The conversion can be activated by software, 16-bit reload timer 1 (rising edge) and 16-bit free-running timer zero detection edge.

14. ROM Correction Function

In the case that the address of the instruction after the one that a program is currently processing matches the address configured in the detection address configuration register, the program forces the next instruction to be processed into an INT9 instruction, and branches to the interrupt process program. Since processing can be conducted using INT9 interrupts, programs can be repaired using batch processing.

•Overview of the Rom correction Function

- The address of the instruction after the one that a program is currently processing is always stored in an address latch via the internal data bus. Address match detection constantly compares the address stored in the address latch with the one configured in the detection address configuration register. If the two compared addresses match, the CPU forcibly changes this instruction into an INT9 instruction, and executes an interrupt processing program.
- There are two detection address configuration registers : PADR0 and PADR1. Each register provides an interrupt enable bit. This allows you to individually configure each register to enable/prohibit the generation of interrupts when the address stored in the address latch matches the one configured in the detection address configuration register.

Block Diagram

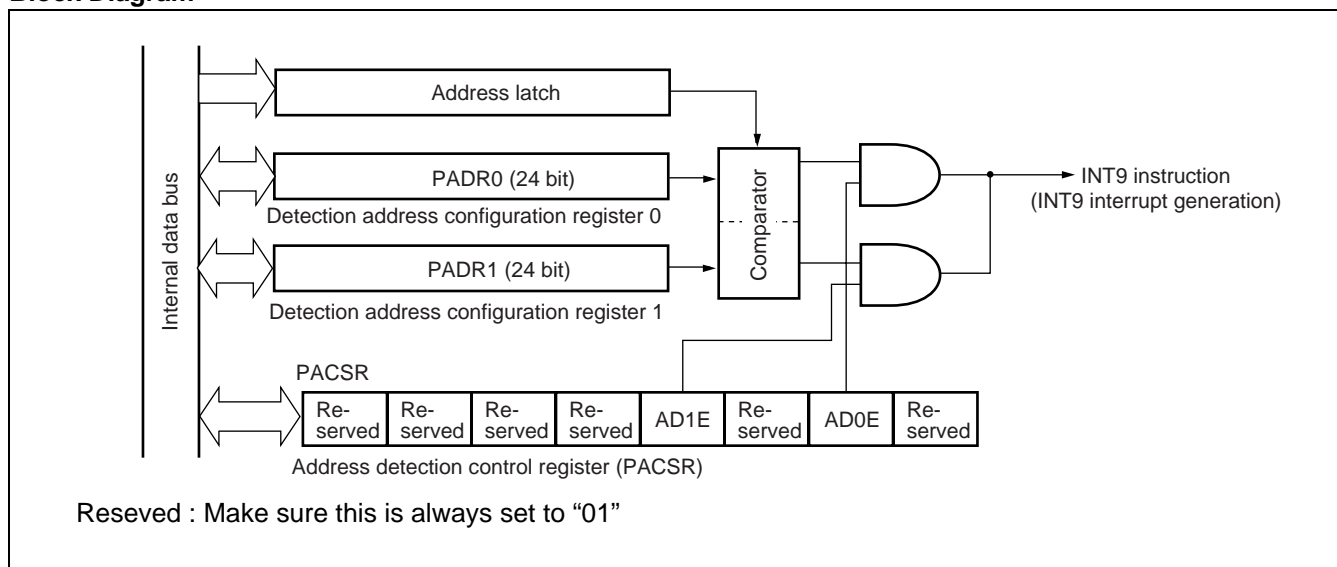

- Address latch
Stores value of address output to internal data bus.
- Address detection control register (PACSR)
Set this register to enable/prohibit interrupt output when an address match is detected.
- Detection address configuration register (PADR0, PADR1)
Configure an address with which to compare the address latch value.

15. ROM Mirroring Function Selection Module

The ROM mirroring function selection module can select what the FF bank allocated the ROM and see through the 00 bank according to register settings.

Block Diagram

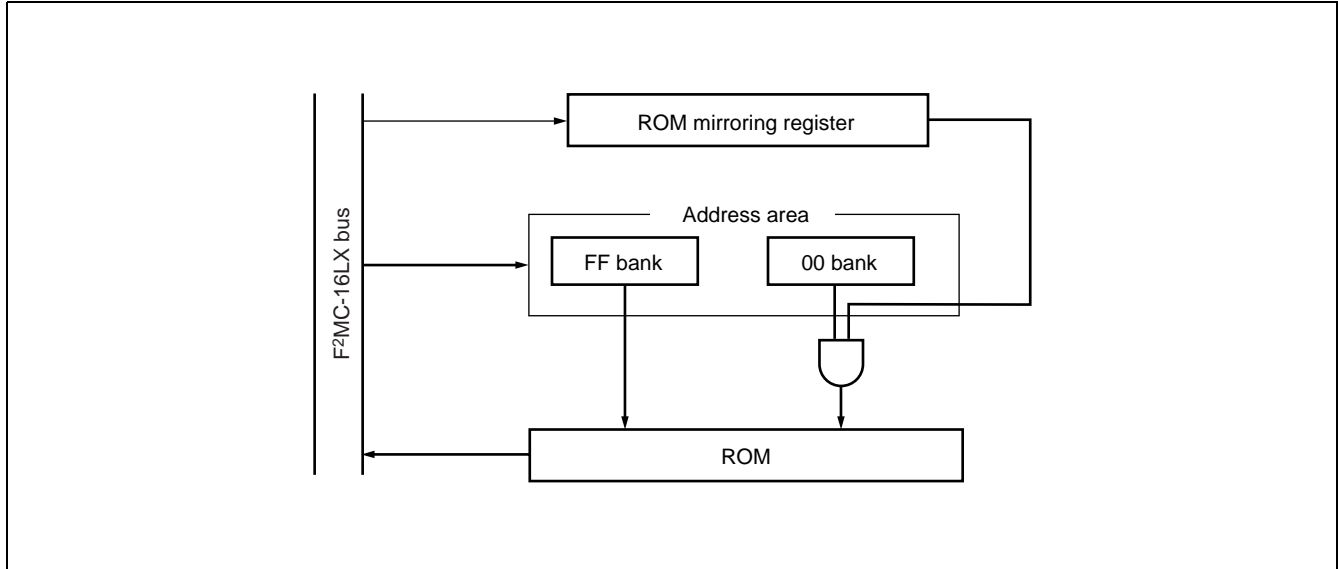

16. 512 Kbit Flash Memory

The 512 Kbit flash memory is allocated in the FE_H to FF_H banks on the CPU memory map. Like masked ROM, flash memory is read-accessible and program-accessible to the CPU using the flash memory interface circuit.

The flash memory can be programmed/erased by the instruction from the CPU via the flash memory interface circuit. The flash memory can therefore be reprogrammed (updated) while still on the circuit board under integrated CPU control, allowing program code and data to be improved efficiently.

Note that sector operations such as “enable sector protect” cannot be used.

Features of 512 Kbit flash memory

- 64 kwords × 8 bits/32 kwords × 16 bits (16 k + 8 k + 8 k + 32 k) sector configuration
- Automatic program algorithm (same as the Embedded Algorithm* : MBM29F400TA)
- Installation of the deletion temporary stop/delete restart function
- Write/delete completion detected by the data polling or toggle bit
- Write/delete completion detected by the CPU interrupt
- Compatibility with the JEDEC standard-type command
- Each sector deletion can be executed (Sectors can be freely combined) .
- Flash security feature
- Number of write/delete operations 10,000 times guaranteed.
- Flash reading cycle time (Min) 2 machine cycles

* : Embedded Algorithm is a trademark of Advanced Micro Devices, Inc.

(1) Register configuration

Flash Memory Control status register								Bit number	
Address : 0000AE _H	7	6	5	4	3	2	1	0	FMCS
	INTE	RDYINT	WE	RDY	Reserved	LPM1	Reserved	LMP0	
Read/write ⇒	R/W	R/W	R/W	R	W	W	W	R/W	
Initial value ⇒	0	0	0	1	0	0	0	0	

MB90460 Series

(2) Sector configuration of 512Kbit flash memory

The 512 Kbit flash memory has the sector configuration illustrated below. The addresses in the illustration are the upper and lower addresses of each sector.

When accessed from the CPU, SA0 to SA3 are allocated in the FF bank registers, respectively.

Flash memory	CPU address	*Writer address
SA3 (16 Kbytes)	FFFFFFH	7FFFFH
	FFC000H	7C000H
SA2 (8 Kbytes)	FFBFFFH	7BFFFH
	FFA000H	7A000H
SA1 (8 Kbytes)	FF9FFFH	79FFFH
	FF8000H	78000H
SA0 (32 Kbytes)	FF7FFFH	77FFFH
	FF0000H	70000H

* : Programmer addresses correspond to CPU addresses when data is programmed in flash memory by a parallel programmer. Programmer addresses are used to program/erase data using a general-purpose programmer.

■ ELECTRICAL CHARACTERISTICS

1. Absolute Maximum Ratings

($V_{SS} = AV_{SS} = 0.0\text{ V}$)

Parameter	Symbol	Rating		Unit	Remarks
		Min	Max		
Power supply voltage	V_{CC}	$V_{SS} - 0.3$	$V_{SS} + 6.0$	V	
	AV_{CC}	$V_{SS} - 0.3$	$V_{SS} + 6.0$	V	$V_{CC} \geq AV_{CC}^{*1}$
	AVR	$V_{SS} - 0.3$	$V_{SS} + 6.0$	V	$AV_{CC} \geq AVR, AVR \geq AV_{SS}$
Input voltage	V_I	$V_{SS} - 0.3$	$V_{SS} + 6.0$	V	*2
Output voltage	V_O	$V_{SS} - 0.3$	$V_{SS} + 6.0$	V	*2
Maximum clamp current	I_{CLAMP}	- 2.0	+ 2.0	mA	*4
Total maximum clamp current	$\Sigma I_{CLAMP} $	—	20	mA	*4
“L” level maximum output current	I_{OL}	—	15	mA	*3
“L” level average output current	I_{OLAV}	—	4	mA	Average output current = operating current \times operating efficiency
“L” level total maximum output current	ΣI_{OL}	—	100	mA	
“L” level total average output current	ΣI_{OLAV}	—	50	mA	Average output current = operating current \times operating efficiency
“H” level maximum output current	I_{OH}	—	- 15	mA	*3
“H” level average output current	I_{OHAV}	—	- 4	mA	Average output current = operating current \times operating efficiency
“H” level total maximum output current	ΣI_{OH}	—	- 100	mA	
“H” level total average output current	ΣI_{OHAV}	—	- 50	mA	Average output current = operating current \times operating efficiency
Power consumption	P_D	—	300	mW	
Operating temperature	T_A	-40	+85	°C	
Storage temperature	T_{stg}	-55	+150	°C	

*1 : AV_{CC} shall never exceed V_{CC} when power on.

*2 : V_I and V_O shall never exceed $V_{CC} + 0.3\text{ V}$.

*3 : The maximum output current is a peak value for a corresponding pin.

*4 : • Applicable to pins : P00 to P07, P10 to P17, P20 to P27, P30 to P37, P40 to P46, P60 to P63

- Use within recommended operating conditions.
- Use at DC voltage (current) .
- The +B signal should always be applied with a limiting resistance placed between the +B signal and the microcontroller.
- The value of the limiting resistance should be set so that when the +B signal is applied the input current to the microcontroller pin does not exceed rated values, either instantaneously or for prolonged periods.

(Continued)

MB90460 Series

(Continued)

- Note that when the microcontroller drive current is low, such as in the power saving modes, the +B input potential may pass through the protective diode and increase the potential at the V_{CC} pin, and this may affect other devices.
- Note that if a +B signal is input when the microcontroller current is off (not fixed at 0 V), the power supply is provided from the pins, so that incomplete operation may result.
- Note that if the +B input is applied during power-on, the power supply is provided from the pins and the resulting supply voltage may not be sufficient to operate the power-on reset.
- Care must be taken not to leave the +B input pin open.
- Note that analog system input/output pins other than the A/D input pins (LCD drive pins, comparator input pins, etc.) cannot accept +B signal input.
- Sample recommended circuits:

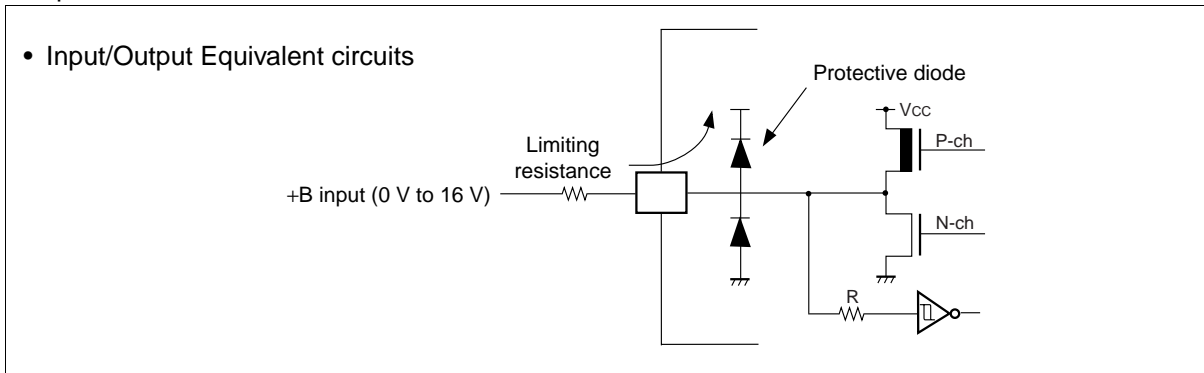

WARNING: Semiconductor devices can be permanently damaged by application of stress (voltage, current, temperature, etc.) in excess of absolute maximum ratings. Do not exceed these ratings.

2. Recommended Operating Conditions

($V_{SS} = AV_{SS} = 0.0\text{ V}$)

Parameter	Symbol	Value		Unit	Remarks
		Min	Max		
Power supply voltage	V_{CC}	3.0	5.5	V	Normal operation (MB90462, MB90467, MB90V460)
		4.5	5.5	V	Normal operation (MB90F462)
	V_{CC}	3.0	5.5	V	Retains status at the time of operation stop
Smoothing capacitor	C_S	0.1	1.0	μF	Use a ceramic capacitor or a capacitor with equivalent frequency characteristics. The smoothing capacitor to be connected to the V_{CC} pin must have a capacitance value higher than C_S .
Operating temperature	T_A	-40	+85	$^{\circ}\text{C}$	

- C pin connection circuit

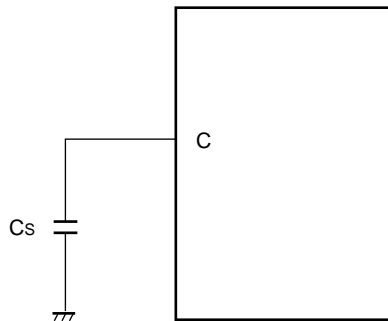

WARNING: The recommended operating conditions are required in order to ensure the normal operation of the semiconductor device. All of the device's electrical characteristics are warranted when the device is operated within these ranges.

Always use semiconductor devices within their recommended operating condition ranges. Operation outside these ranges may adversely affect reliability and could result in device failure.

No warranty is made with respect to uses, operating conditions, or combinations not represented on the data sheet. Users considering application outside the listed conditions are advised to contact their FUJITSU representatives beforehand.

MB90460 Series

3. DC Characteristics

($V_{CC} = 5.0\text{ V} \pm 10\%$, $V_{SS} = AV_{SS} = 0.0\text{ V}$, $T_A = -40\text{ }^\circ\text{C}$ to $+85\text{ }^\circ\text{C}$)

Parameter	Symbol	Pin name	Condition	Value			Unit	Remarks
				Min	Typ	Max		
"H" level output voltage	V_{OH}	All output pins	$V_{CC} = 4.5\text{ V}$, $I_{OH} = -4.0\text{ mA}$	$V_{CC} - 0.5$	—	—	V	
"L" level output voltage	V_{OL}	All pins except P00 to P05 and P30 to P35	$V_{CC} = 4.5\text{ V}$, $I_{OL} = 4.0\text{ mA}$	—	—	0.4	V	
		P00 to P05, P30 to P35	$V_{CC} = 4.5\text{ V}$, $I_{OL} = 12.0\text{ mA}$	—	—	0.4	V	
"H" level input voltage	V_{IH}	P00 to P07 P30 to P37 P50 to P57	$V_{CC} = 3.0\text{ V}$ to 5.5 V (MB90462)	$0.7 V_{CC}$	—	$V_{CC} + 0.3$	V	CMOS input pin
	V_{IHS}	P10 to P17 P20 to P27 P40 to P46 P60 to P63, \overline{RST}		$0.8 V_{CC}$	—	$V_{CC} + 0.3$	V	CMOS hysteresis input pin
	V_{IHM}	MD pins		$V_{CC} - 0.3$	—	$V_{CC} + 0.3$	V	MD pin input
"L" level input voltage	V_{IL}	P00 to P07 P30 to P37 P50 to P57	$V_{CC} = 4.5\text{ V}$ to 5.5 V (MB90F462)	$V_{SS} - 0.3$	—	$0.3 V_{CC}$	V	CMOS input pin
	V_{ILS}	P10 to P17 P20 to P27 P40 to P46 P60 to P63, \overline{RST}		$V_{SS} - 0.3$	—	$0.2 V_{CC}$	V	CMOS hysteresis input pin
	V_{ILM}	MD pins		$V_{SS} - 0.3$	—	$V_{SS} + 0.3$	V	MD pin input
Input leakage current	I_{IL}	All input pins	$V_{CC} = 5.5\text{ V}$, $V_{SS} < V_I < V_{CC}$	-5	—	5	μA	
Power supply current*	I_{CC}	V_{CC}	$V_{CC} = 5.0\text{ V}$, Internal operation at 16 MHz, Normal operation	—	40	50	mA	
			$V_{CC} = 5.0\text{ V}$, Internal operation at 16 MHz, When data written in flash mode programming of erasing	—	45	60	mA	
	I_{CCS}		$V_{CC} = 5.0\text{ V}$, Internal operation at 16 MHz, In sleep mode	—	15	20	mA	

(Continued)

MB90460 Series

(Continued)

($V_{CC} = 5.0 \text{ V} \pm 10\%$, $V_{SS} = AV_{SS} = 0.0 \text{ V}$, $T_A = -40 \text{ }^\circ\text{C}$ to $+85 \text{ }^\circ\text{C}$)

Parameter	Symbol	Pin name	Condition	Value			Unit	Remarks
				Min	Typ	Max		
Power supply current*	I_{CTS}	V_{CC}	$V_{CC} = 5.0 \text{ V}$, Internal operation at 16 MHz, In Timer mode, $T_A = 25 \text{ }^\circ\text{C}$	—	2.5	5.0	mA	
	I_{CCH}		In stop mode, $T_A = 25 \text{ }^\circ\text{C}$	—	5	20	μA	
Input capacitance	C_{IN}	Except AV_{CC} , AV_{SS} , C, V_{CC} and V_{SS}	—	—	10	80	pF	
Pull-up resistance	R_{UP}	P00 to P07 P10 to P17 \overline{RST}	—	25	50	100	k Ω	
Pull-down resistance	R_{DOWN}	MD2	—	25	50	100	k Ω	

* : The current value is preliminary value and may be subject to change for enhanced characteristics without previous notice. The power supply current is measured with an external clock.

MB90460 Series

4. AC Characteristics

(1) Clock Timings

(V_{CC} = 5.0 V ± 10%, V_{SS} = AV_{SS} = 0.0 V, T_A = -40 °C to +85 °C)

Parameter	Symbol	Pin name	Value			Unit	Remarks
			Min	Typ	Max		
Clock frequency	f _c	X0, X1	3	—	16	MHz	Crystal oscillator
			3	—	32		External clock *2
Clock cycle time	t _{H CYL}	X0, X1	62.5	—	333	ns	
Frequency fluctuation rate locked*1	Δf	—	—	—	5	%	
Input clock pulse width	P _{WH} P _{WL}	X0	10	—	—	ns	Recommended duty ratio of 30% to 70%
Input clock rise/fall time	t _{CR} t _{CF}	X0	—	—	5	ns	External clock operation
Internal operating clock	f _{CP}	—	1.5	—	16	MHz	Main clock operation
Internal operating clock cycle time	t _{CP}	—	62.5	—	666	ns	Main clock operation

*1 : The frequency fluctuation rate is the maximum deviation rate of the preset center frequency when the multiplied PLL signal is locked.

*2 : Internal operating clock frequency must not be over 16 MHz.

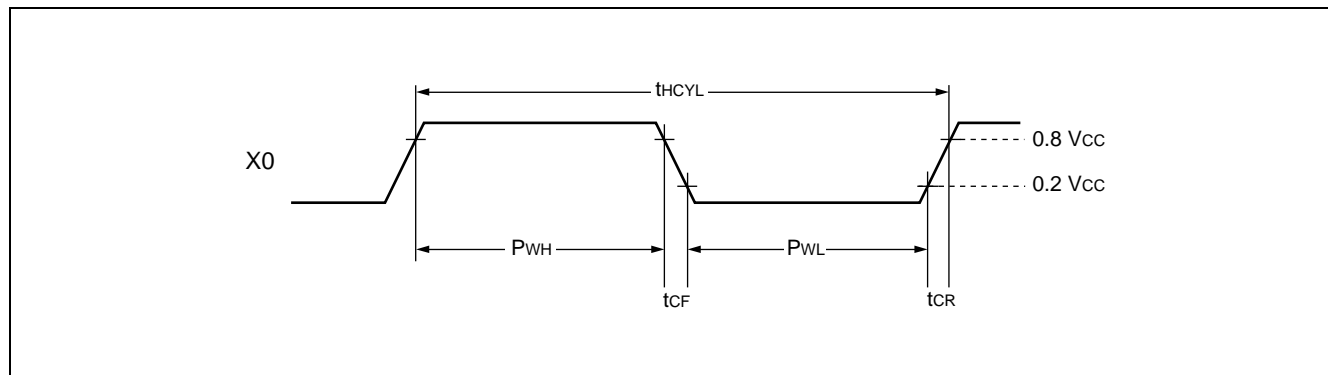
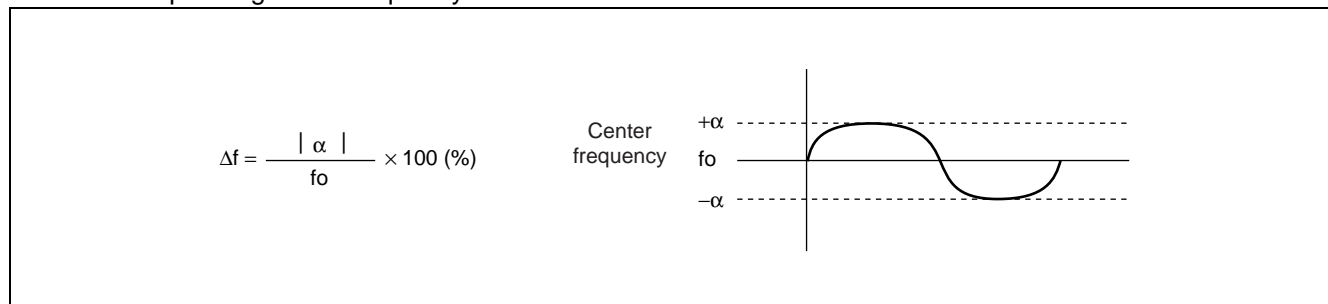

Relationship between internal operating clock frequency and power supply voltage

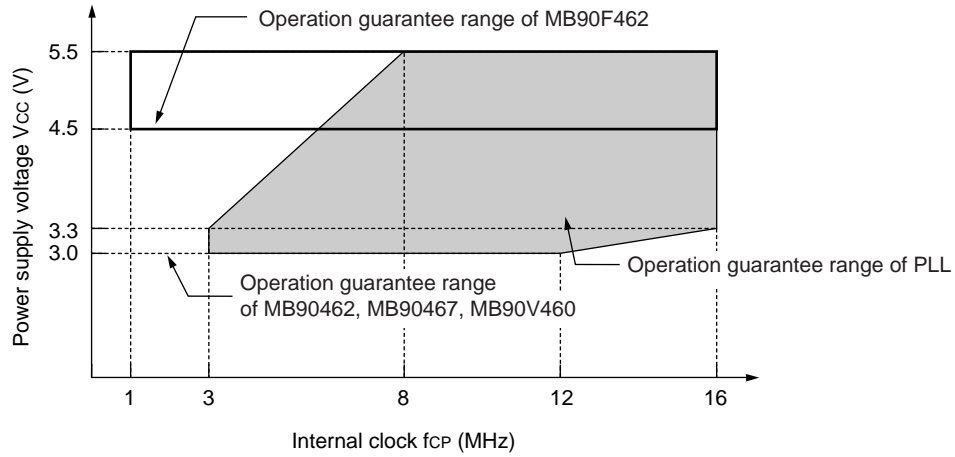

Relationship between oscillating frequency and internal operating clock frequency

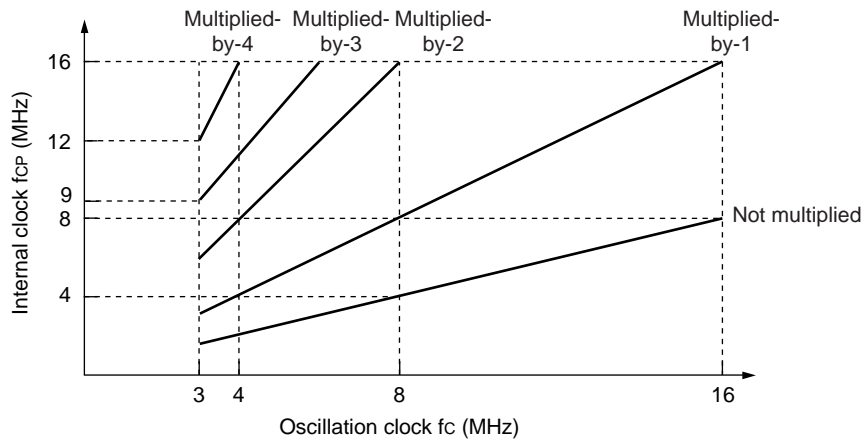

The AC ratings are measured for the following measurement reference voltages

• **Input signal waveform**

Hysteresis Input Pin



Pin other than hysteresis input/MD input

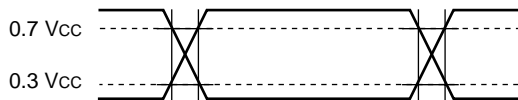

• **Output signal waveform**

Output Pin



MB90460 Series

(2) Reset Input Timing

($V_{CC} = 5.0 \text{ V} \pm 10\%$, $V_{SS} = AV_{SS} = 0.0 \text{ V}$, $T_A = -40 \text{ }^\circ\text{C}$ to $+85 \text{ }^\circ\text{C}$)

Parameter	Symbol	Pin	Condition	Value		Units	Remarks
				Min	Max		
Reset input time	t_{RSTL}	$\overline{\text{RST}}$	—	4 t_{CP}	—	ns	Under normal operation
				Oscillation time of oscillator + 4 t_{CP} *	—	ms	In stop mode

* : Oscillation time of oscillator is time that amplitude reached the 90%. In the crystal oscillator, the oscillation time is between several ms to tens of ms. In FAR/ceramic oscillator, the oscillation time is between hundreds μs to several ms. In the external clock, the oscillation time is 0 ms.

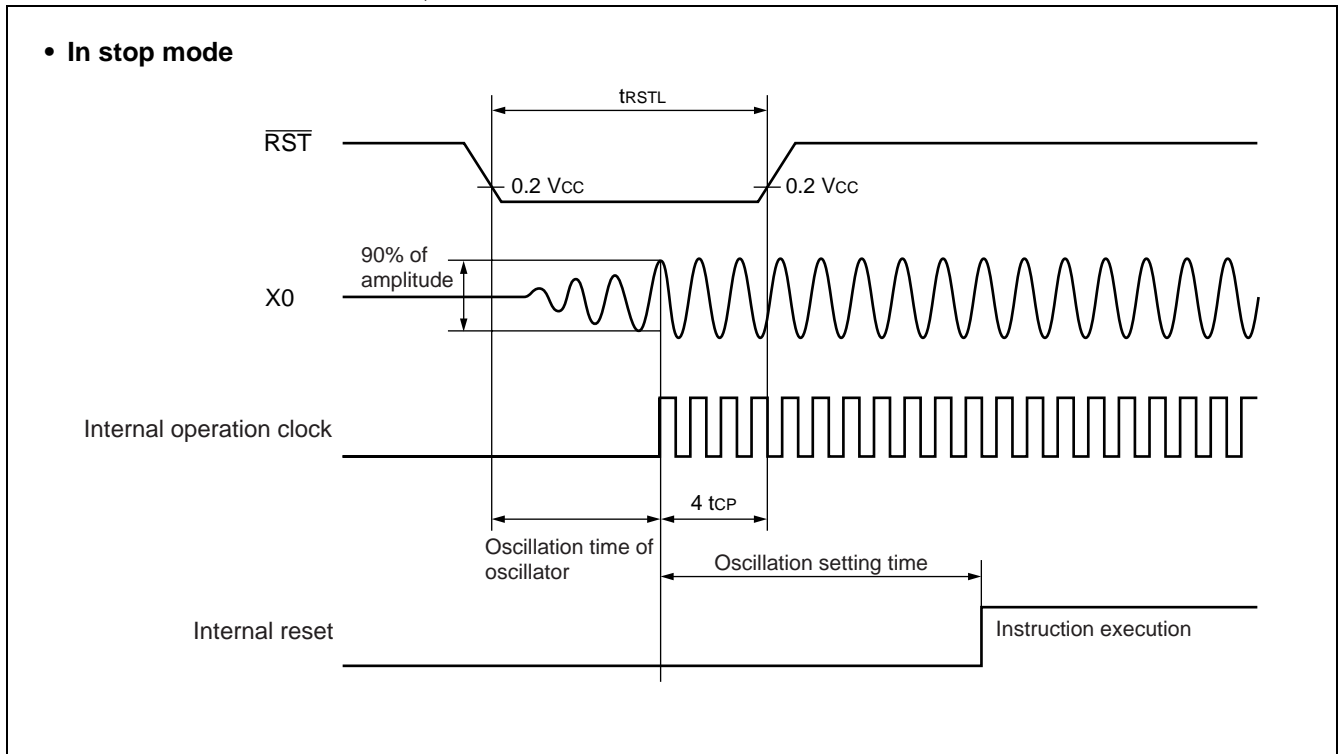

(3) Power-on Reset

($V_{CC} = 5.0\text{ V} \pm 10\%$, $V_{SS} = AV_{SS} = 0.0\text{ V}$, $T_A = -40\text{ }^\circ\text{C}$ to $+85\text{ }^\circ\text{C}$)

Parameter	Symbol	Pin name	Condition	Value		Unit	Remarks
				Min	Max		
Power supply rising time	t_R	V_{CC}	—	0.05	30	ms	
Power supply cut-off time	t_{OFF}	V_{CC}	—	4	—	ms	Due to repeated operations

Note : V_{CC} must be kept lower than 0.2 V before power-on.

The above values are used for causing a power-on reset.

Some registers in the device are initialized only upon a power-on reset. To initialize these registers, turn the power supply using the above values.

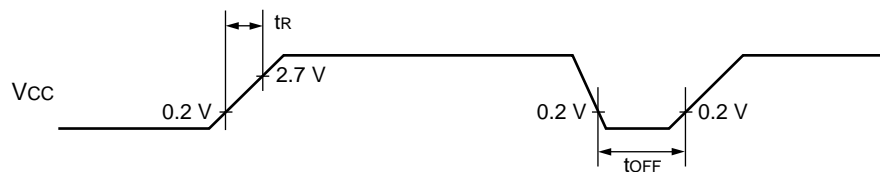

Sudden changes in the power supply voltage may cause a power-on reset.

To change the power supply voltage while the device is in operation, it is recommended to raise the voltage smoothly to suppress fluctuations as shown below.

In this case, change the supply voltage with the PLL clock not used. If the voltage drop is 1 V or fewer per second, however, you can use the PLL clock.

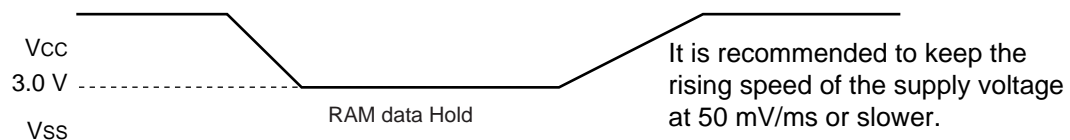

MB90460 Series

(4) UART0 to UART1

($V_{CC} = 5.0 \text{ V} \pm 10\%$, $V_{SS} = AV_{SS} = 0.0 \text{ V}$, $T_A = -40 \text{ }^\circ\text{C}$ to $+85 \text{ }^\circ\text{C}$)

Parameter	Symbol	Pin name	Condition	Value		Unit	Remarks
				Min	Max		
Serial clock cycle time	t _{SCYC}	SCK0 to SCK1	C _L = 80 pF + 1 TTL for an output pin of internal shift clock mode	8 t _{CP}	—	ns	
SCK ↓ → SOT delay time	t _{SLOV}	SCK0 to SCK1 SOT0 to SOT1		-80	80	ns	
Valid SIN → SCK ↑	t _{IVSH}	SCK0 to SCK1 SIN0 to SIN1		100	—	ns	
SCK ↑ → valid SIN hold time	t _{SHIX}	SCK0 to SCK1, SIN0 to SIN1		60	—	ns	
Serial clock "H" pulse width	t _{SHSL}	SCK0 to SCK1	C _L = 80 pF + 1 TTL for an output pin of external shift clock mode	4 t _{CP}	—	ns	
Serial clock "L" pulse width	t _{LSLH}	SCK0 to SCK1		4 t _{CP}	—	ns	
SCK ↓ → SOT delay time	t _{SLOV}	SCK0 to SCK1, SOT0 to SOT1		—	150	ns	
Valid SIN → SCK ↑	t _{IVSH}	SCK0 to SCK1, SIN0 to SIN1		60	—	ns	
SCK ↑ → valid SIN hold time	t _{SHIX}	SCK0 to SCK1, SIN0 to SIN1		60	—	ns	

- Note :
- These are AC ratings in the CLK synchronous mode.
 - C_L is the load capacitance value connected to pins while testing.
 - t_{CP} is machine cycle time (unit : ns) .

- Internal shift clock mode

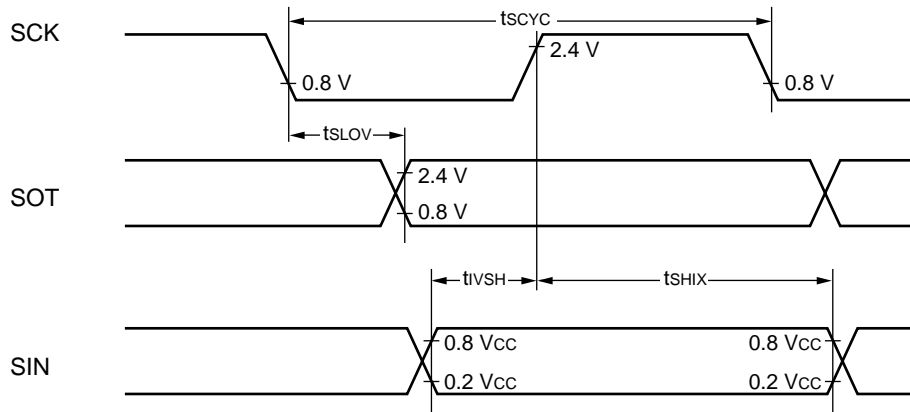

- External shift clock mode

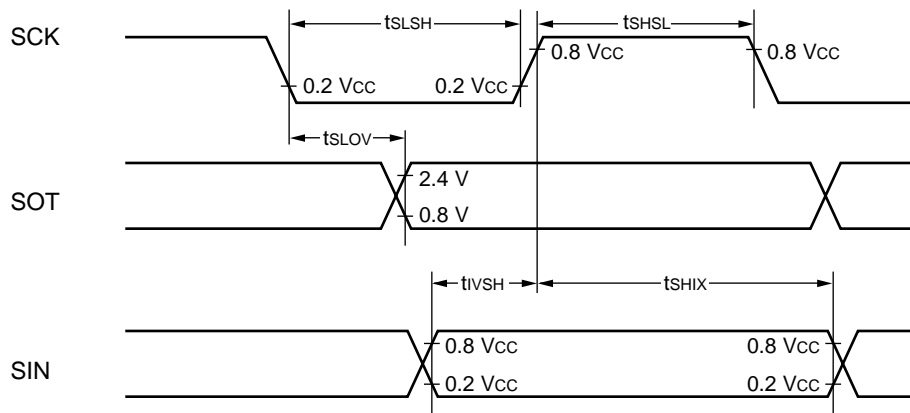

MB90460 Series

(5) Resources Input Timing

($V_{CC} = 5.0\text{ V} \pm 10\%$, $V_{SS} = AV_{SS} = 0.0\text{ V}$, $T_A = -40\text{ }^\circ\text{C}$ to $+85\text{ }^\circ\text{C}$)

Parameter	Symbol	Pin name	Condition	Value		Unit	Remarks
				Min	Max		
Input pulse width	t_{TIWH} t_{TIWL}	IN0 to IN3, SNI0 to SNI2 TIN0 to TIN1 PWI0 to PWI1 DTTI0, DTTI1	—	4 t_{CP}	—	ns	

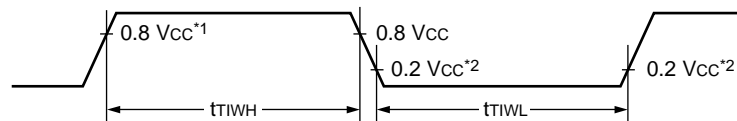

*1 : $0.7 V_{CC}$ for PWI0 input pin

*2 : $0.3 V_{CC}$ for PWI0 Input pin

(6) Trigger Input Timing

($V_{CC} = 5.0\text{ V} \pm 10\%$, $V_{SS} = AV_{SS} = 0.0\text{ V}$, $T_A = -40\text{ }^\circ\text{C}$ to $+85\text{ }^\circ\text{C}$)

Parameter	Symbol	Pin name	Condition	Value		Unit	Remarks
				Min	Max		
Input pulse width	t_{TRGH} t_{TRGL}	INT0 to INT7	—	5 t_{CP}	—	ns	

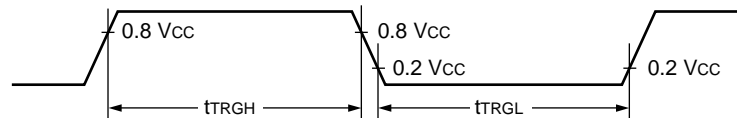

5. A/D Converter Electrical Characteristics

($3.0\text{ V} \leq \text{AVR} - \text{AV}_{\text{SS}}, V_{\text{CC}} = \text{AV}_{\text{CC}} = 5.0\text{ V} \pm 10\%$, $V_{\text{SS}} = \text{AV}_{\text{SS}} = 0.0\text{ V}$, $T_{\text{A}} = -40\text{ }^{\circ}\text{C}$ to $+85\text{ }^{\circ}\text{C}$)

Parameter	Symbol	Pin name	Value			Unit	Remarks
			Min	Typ	Max		
Resolution	—	—	—	10	—	bit	
Total error	—	—	—	—	± 3.0	LSB	For MB90F462, MB90462, MB90467
	—	—	—	—	± 5.0	LSB	For MB90V460
Non-linear error	—	—	—	—	± 2.5	LSB	
Differential linearity error	—	—	—	—	± 1.9	LSB	
Zero transition voltage	V_{OT}	AN0 to AN7	$\text{AV}_{\text{SS}} - 1.5\text{ LSB}$	$\text{AV}_{\text{SS}} + 0.5\text{ LSB}$	$\text{AV}_{\text{SS}} + 2.5\text{ LSB}$	mV	For MB90F462, MB90462, MB90467
			$\text{AV}_{\text{SS}} - 3.5\text{ LSB}$	$\text{AV}_{\text{SS}} + 0.5\text{ LSB}$	$\text{AV}_{\text{SS}} + 4.5\text{ LSB}$	mV	For MB90V460
Full-scale transition voltage	V_{FST}	AN0 to AN7	$\text{AVR} - 3.5\text{ LSB}$	$\text{AVR} - 1.5\text{ LSB}$	$\text{AVR} + 0.5\text{ LSB}$	mV	For MB90F462, MB90462, MB90467
			$\text{AVR} - 6.5\text{ LSB}$	$\text{AVR} - 1.5\text{ LSB}$	$\text{AVR} + 1.5\text{ LSB}$	mV	For MB90V460
Conversion time	—	—	6.125	—	1000	μs	Actual value is specified as a sum of values specified in ADCR0 : CT1, CT0 and ADCR0 : ST1, ST0. Be sure that the setting value is greater than the min value
Sampling period	—	—	2	—	—	μs	Actual value is specified in ADCR0 : ST1, ST0 bits. Be sure that the setting value is greater than the min value
Analog port input current	I_{AIN}	AN0 to AN7	—	—	10	μA	
Analog input voltage	V_{AIN}	AN0 to AN7	AV_{SS}	—	AVR	V	
Reference voltage	—	AVR	$\text{AV}_{\text{SS}} + 2.7$	—	AV_{CC}	V	
Power supply current	I_{A}	AV_{CC}	—	2.3	6	mA	For MB90F462, MB90462, MB90467
			—	2	5	mA	For MB90V460
	I_{AH}^*	—	—	5	μA	*	
Reference voltage supply current	IR	AVR	—	140	260	μA	For MB90F462, MB90462, MB90467
			—	0.9	1.3	mA	For MB90V460
	I_{RH}^*	—	—	5	μA	*	
Offset between channels	—	AN0 to AN7	—	—	4	LSB	

* : The current when the A/D converter is not operating or the CPU is in stop mode (for $V_{\text{CC}} = \text{AV}_{\text{CC}} = \text{AVR} = 5.0\text{ V}$)

MB90460 Series

6. A/D Converter Glossary

- Resolution : Analog changes that are identifiable with the A/D converter
- Linearity error : The deviation of the straight line connecting the zero transition point (“00 0000 0000” ↔ “000000 0001”) with the full-scale transition point (“11 1111 1110” ↔ “11 1111 1111”) from actual conversion characteristics
- Differential linearity error : The deviation of input voltage needed to change the output code by 1 LSB from the theoretical value
- Total error : The total error is defined as a difference between the actual value and the theoretical value, which includes zero-transition error/full-scale transition error and linearity error.

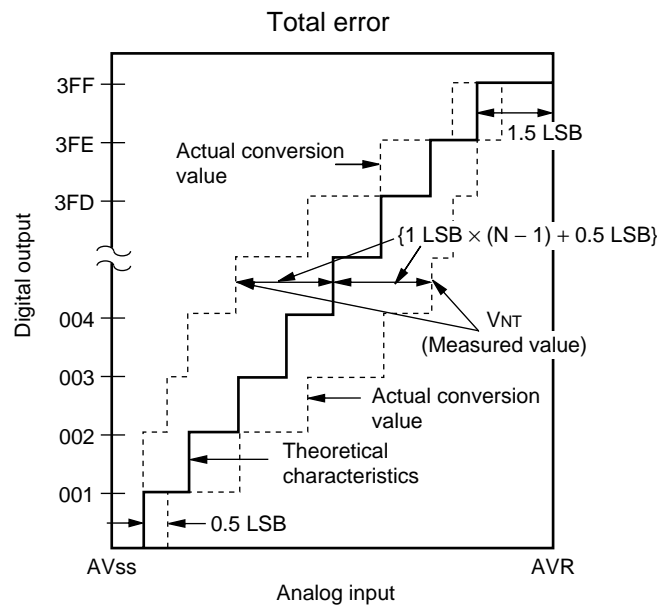

$$\text{Total error for digital output } N = \frac{V_{NT} - \{1 \text{ LSB} \times (N - 1) + 0.5 \text{ LSB}\}}{1 \text{ LSB}} \text{ [LSB]}$$

$$1 \text{ LSB} = (\text{Theoretical value}) \frac{AVR - AV_{SS}}{1024} \text{ [V]}$$

$$V_{OT} (\text{Theoretical value}) = AV_{SS} + 0.5 \text{ LSB [V]}$$

$$V_{FST} (\text{Theoretical value}) = AVR - 1.5 \text{ LSB [V]}$$

V_{NT} : Voltage at a transition of digital output from (N - 1) to N

(Continued)

(Continued)

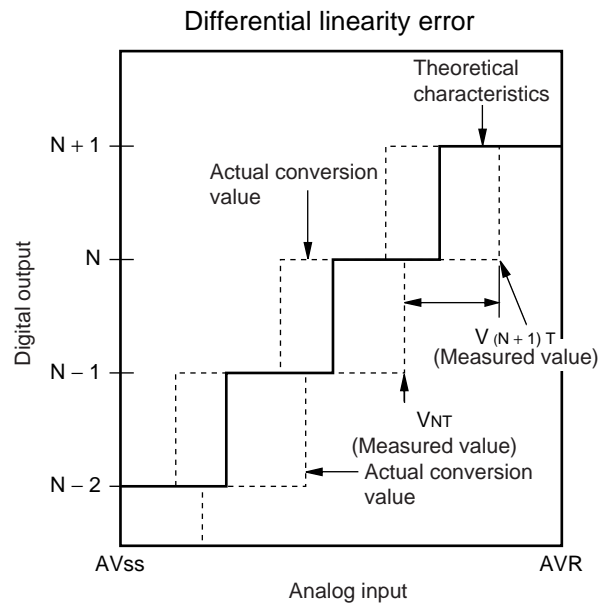
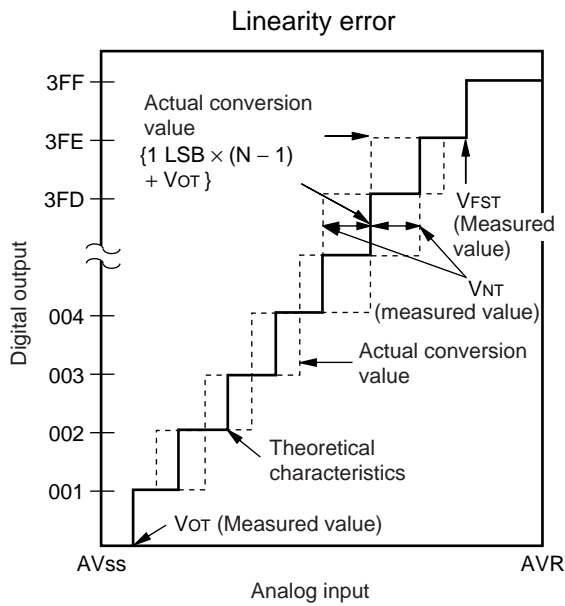

$$\text{Linearity error of digital output N} = \frac{V_{NT} - \{1 \text{ LSB} \times (N - 1) + V_{OT}\}}{1 \text{ LSB}} \text{ [LSB]}$$

$$\text{Differential linearity error of digital output N} = \frac{V_{(N+1)T} - V_{NT}}{1 \text{ LSB}} - 1 \text{ [LSB]}$$

$$1 \text{ LSB} = \frac{V_{FST} - V_{OT}}{1022} \text{ [V]}$$

V_{OT} : Voltage at transition of digital output from "000_H" to "001_H"

V_{FST} : Voltage at transition of digital output from "3FE_H" to "3FF_H"

MB90460 Series

7. Notes on Using A/D Converter

Select the output impedance value for the external circuit of analog input according to the following conditions.

Output impedance values of the external circuit recommends about 5 kΩ or lower (sampling period = 2.0 μs @ machine clock of 16 MHz) .

When capacitors are connected to external pins, the capacitance of several thousand times the internal capacitor value is recommended to minimized the effect of voltage distribution between the external capacitor and internal capacitor.

When the output impedance of the external circuit is too high, the sampling period for analog voltages may not be sufficient.

- Analog input circuit model

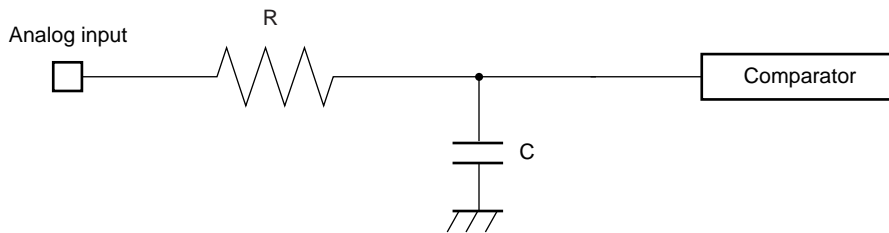

MB90462, MB90F462, MB90467 R ≅ 2.6 KΩ, C ≅ 28 pF
 MB90V460 R ≅ 3.2 KΩ, C ≅ 30 pF

Note : Listed values must be considered as standards.

- Error

The smaller the absolute value of | AVR – AV_{SS} |, the greater the error would become relatively.

8. Flash Memory Program and Erase Performances

Parameter	Condition	Value			Unit	Remarks
		Min	Typ	Max		
Sector erase time	T _A = + 25 °C V _{CC} = 3.0 V	—	1	15	s	Excludes 00H programming prior erasure
Chip erase time		—	5	—	s	Excludes 00 H programming prior erasure
Word (16 bit width) programming time		—	16	3,600	μs	Excludes system-level overhead
Erase/Program cycle	—	10,000	—	—	cycle	

EXAMPLE CHARACTERISTICS

- Power Supply Current of MB90462, MB90467

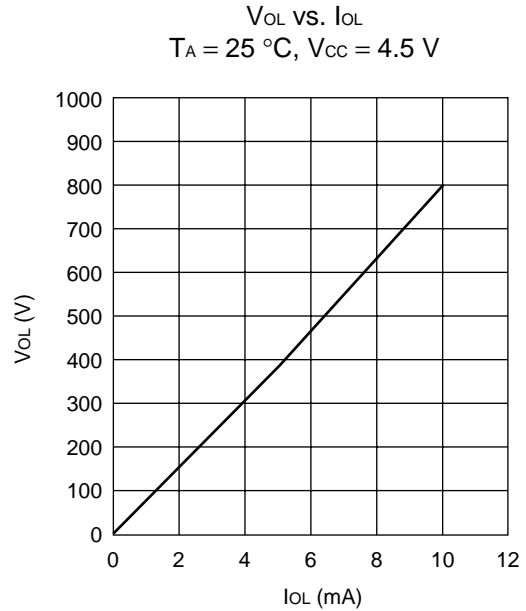
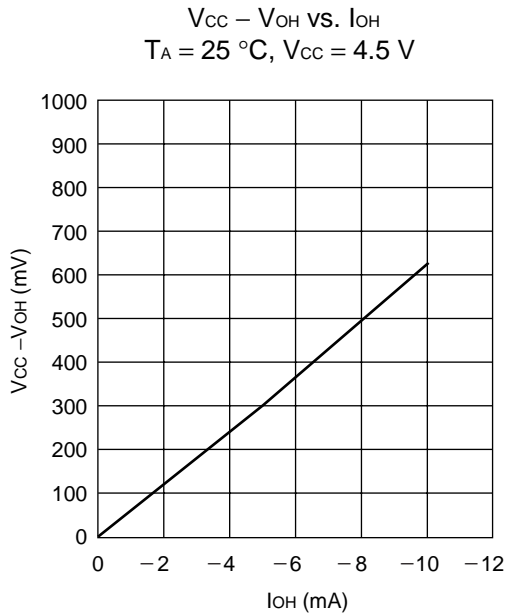
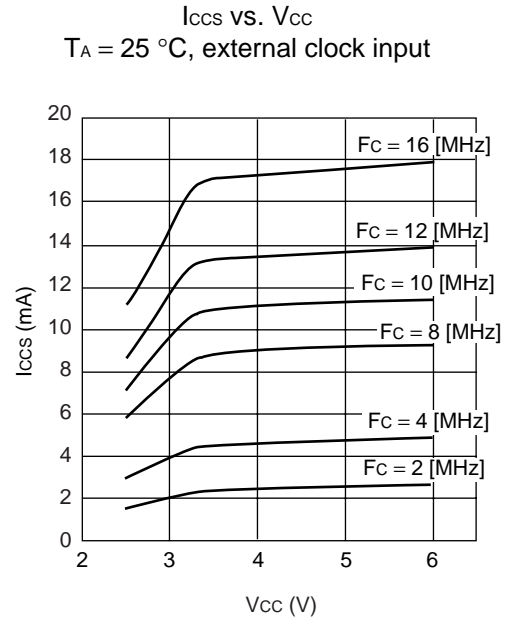
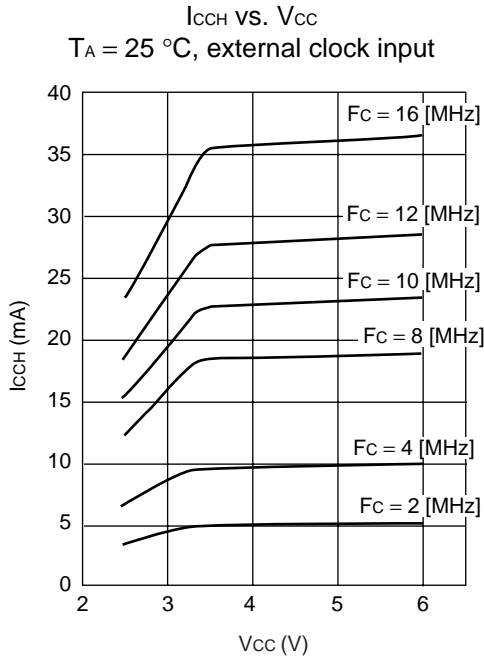

MB90460 Series

- Power Supply Current of MB90F462

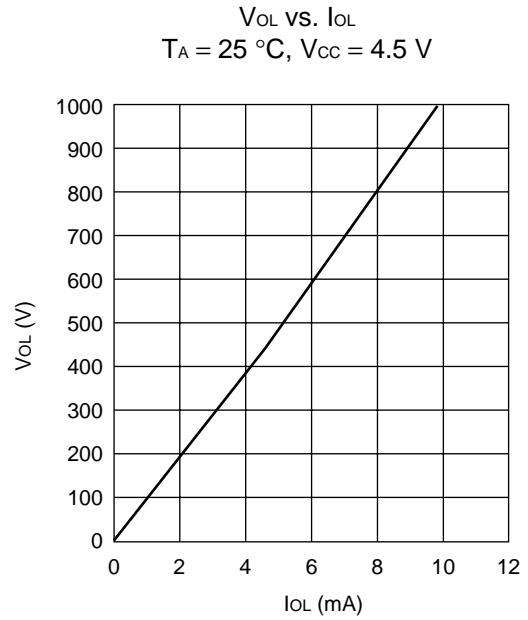
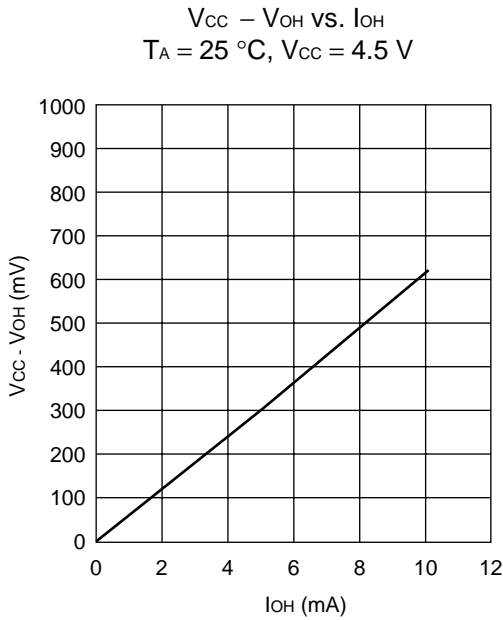
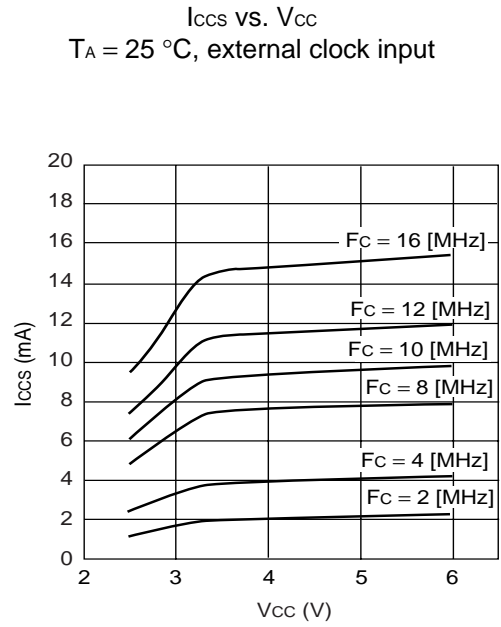
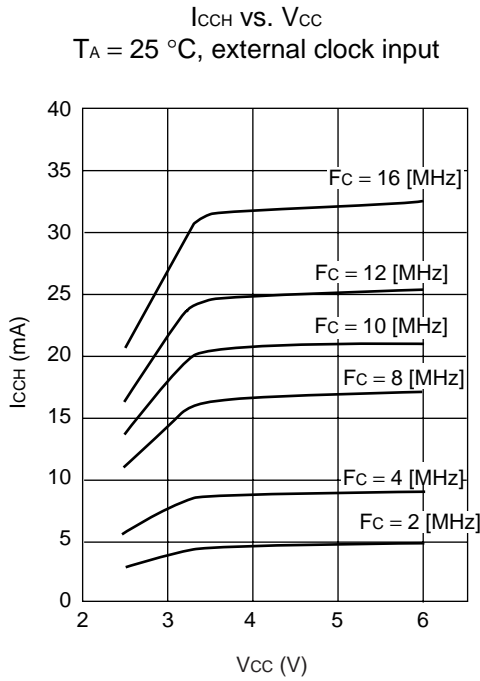

■ ORDERING INFORMATION

Part number	Package	Remarks
MB90F462PFM MB90462PFM MB90467PFM	64-pin Plastic LQFP (FPT-64P-M09)	
MB90F462PF MB90462PF MB90467PF	64-pin Plastic QFP (FPT-64P-M06)	
MB90F462P-SH MB90462P-SH MB90467P-SH	64-pin Plastic SH-DIP (DIP-64P-M01)	

MB90460 Series

PACKAGE DIMENSIONS

64-pin Plastic QFP
(FPT-64P-M06)

Note : Pins width and pins thickness include plating thickness.

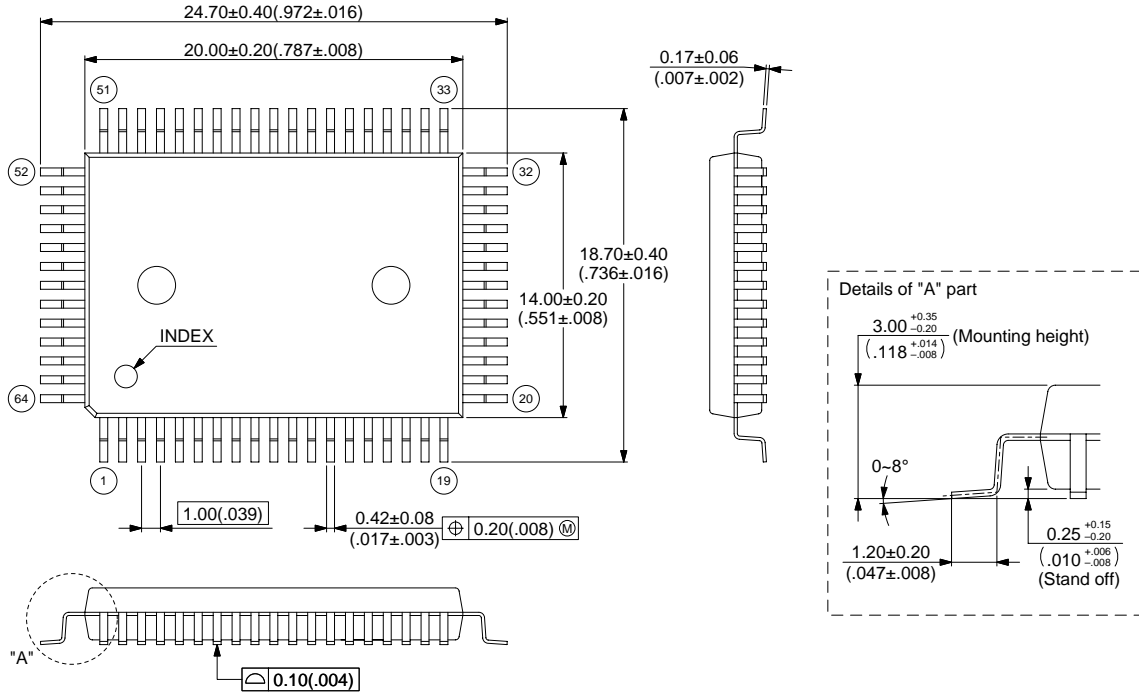

© 2001 FUJITSU LIMITED F64013S-c-4-4

Dimensions in mm (inches)

MB90460 Series

64-pin Plastic LQFP
(FPT-64P-M09)

Note : Pins width and pins thickness include plating thickness.

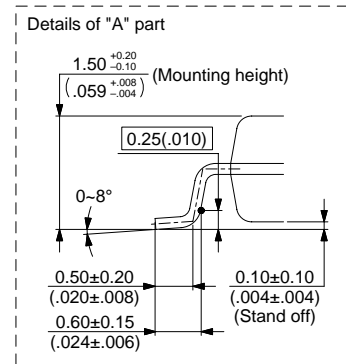
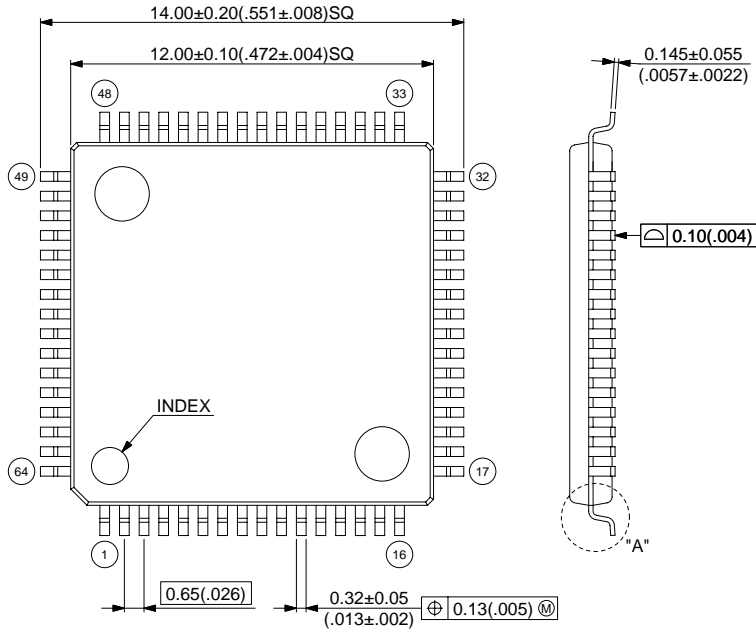

© 2001 FUJITSU LIMITED F64018S-c-2-4

Dimensions in mm (inches)

MB90460 Series

64-pin Plastic SH-DIP
(DIP-64P-M01)

Note : Pins width and pins thickness include plating thickness.

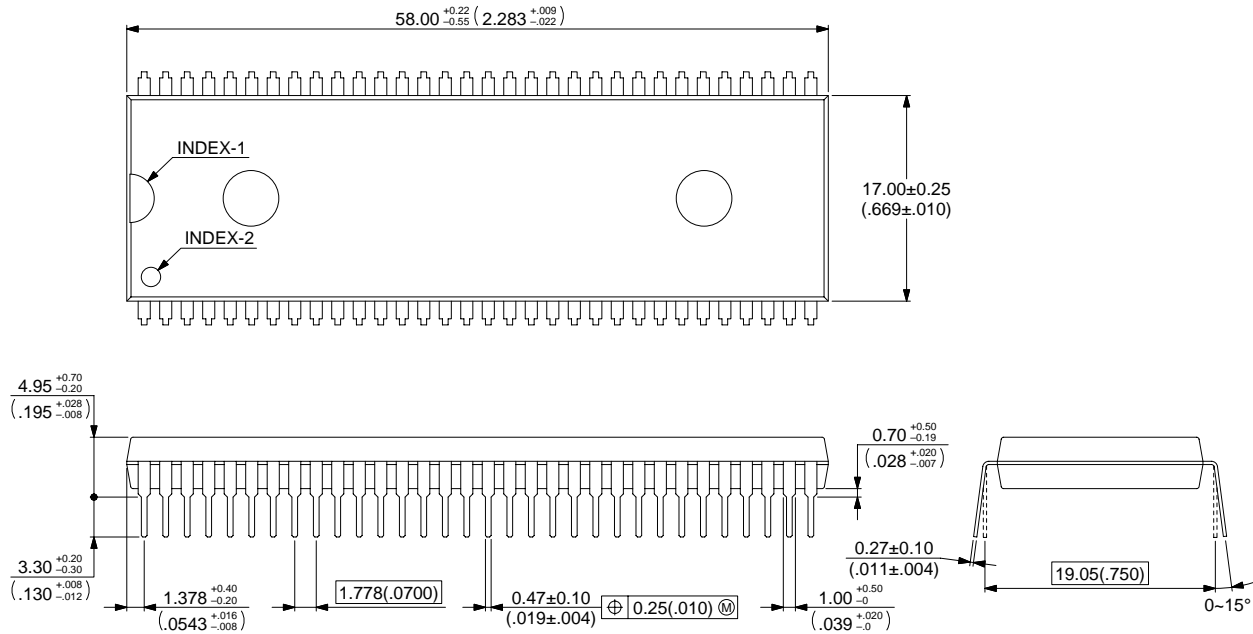

© 2001 FUJITSU LIMITED D64001S-c-4-5

Dimensions in mm (inches)

FUJITSU LIMITED

For further information please contact:

Japan

FUJITSU LIMITED
Marketing Division
Electronic Devices
Shinjuku Dai-Ichi Seimei Bldg. 7-1,
Nishishinjuku 2-chome, Shinjuku-ku,
Tokyo 163-0721, Japan
Tel: +81-3-5322-3353
Fax: +81-3-5322-3386

<http://edevice.fujitsu.com/>

North and South America

FUJITSU MICROELECTRONICS AMERICA, INC.
3545 North First Street,
San Jose, CA 95134-1804, U.S.A.
Tel: +1-408-922-9000
Fax: +1-408-922-9179

Customer Response Center
Mon. - Fri.: 7 am - 5 pm (PST)
Tel: +1-800-866-8608
Fax: +1-408-922-9179

<http://www.fma.fujitsu.com/>

Europe

FUJITSU MICROELECTRONICS EUROPE GmbH
Am Siebenstein 6-10,
D-63303 Dreieich-Buchsschlag,
Germany
Tel: +49-6103-690-0
Fax: +49-6103-690-122

<http://www.fme.fujitsu.com/>

Asia Pacific

FUJITSU MICROELECTRONICS ASIA PTE. LTD.
#05-08, 151 Lorong Chuan,
New Tech Park,
Singapore 556741
Tel: +65-281-0770
Fax: +65-281-0220

<http://www.fmal.fujitsu.com/>

Korea

FUJITSU MICROELECTRONICS KOREA LTD.
1702 KOSMO TOWER, 1002 Daechi-Dong,
Kangnam-Gu, Seoul 135-280
Korea
Tel: +82-2-3484-7100
Fax: +82-2-3484-7111

F0112

© FUJITSU LIMITED Printed in Japan

All Rights Reserved.

The contents of this document are subject to change without notice. Customers are advised to consult with FUJITSU sales representatives before ordering.

The information and circuit diagrams in this document are presented as examples of semiconductor device applications, and are not intended to be incorporated in devices for actual use. Also, FUJITSU is unable to assume responsibility for infringement of any patent rights or other rights of third parties arising from the use of this information or circuit diagrams.

The products described in this document are designed, developed and manufactured as contemplated for general use, including without limitation, ordinary industrial use, general office use, personal use, and household use, but are not designed, developed and manufactured as contemplated (1) for use accompanying fatal risks or dangers that, unless extremely high safety is secured, could have a serious effect to the public, and could lead directly to death, personal injury, severe physical damage or other loss (i.e., nuclear reaction control in nuclear facility, aircraft flight control, air traffic control, mass transport control, medical life support system, missile launch control in weapon system), or (2) for use requiring extremely high reliability (i.e., submersible repeater and artificial satellite).

Please note that Fujitsu will not be liable against you and/or any third party for any claims or damages arising in connection with above-mentioned uses of the products.

Any semiconductor devices have an inherent chance of failure. You must protect against injury, damage or loss from such failures by incorporating safety design measures into your facility and equipment such as redundancy, fire protection, and prevention of over-current levels and other abnormal operating conditions.

If any products described in this document represent goods or technologies subject to certain restrictions on export under the Foreign Exchange and Foreign Trade Law of Japan, the prior authorization by Japanese government will be required for export of those products from Japan.