

# GP1A58HR

## OPIC Photointerrupter

### ■ Features

1. High sensing accuracy (Slit width: 0.5mm)
2. PWB mounting type

### ■ Applications

1. OA equipment such as printers, facsimiles, etc.
2. VCRs

### ■ Outline Dimensions

(Unit : mm)

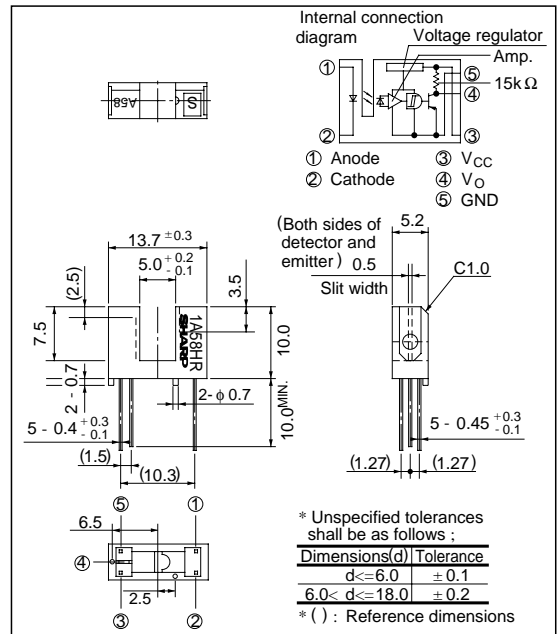

“OPIC” (Optical IC) is a trademark of the SHARP Corporation.  
An OPIC consists of a light-detecting element and signal-processing circuit integrated onto a single chip.

### ■ Absolute Maximum Ratings

(T<sub>a</sub> = 25°C)

Parameter		Symbol	Rating	Unit
Input	Forward current	I <sub>F</sub>	50	mA
	*1 Peak forward current	I <sub>FM</sub>	1	A
	Reverse voltage	V <sub>R</sub>	6	V
	Power dissipation	P	75	mW
Output	Supply voltage	V <sub>CC</sub>	- 0.5 to + 17	mA
	Output current	I <sub>O</sub>	50	mA
	Power dissipation	P <sub>O</sub>	250	mW
Operating temperature		T <sub>opr</sub>	- 25 to + 85	°C
Storage temperature		T <sub>stg</sub>	- 40 to + 100	°C
*2 Soldering temperature		T <sub>sol</sub>	260	°C

\*1 Pulse width ≤ 100 $\mu$ s, Duty ratio = 0.01

\*2 For 5 seconds

## Electro-optical Characteristics

(Ta = 25°C)

Parameter		Symbol	Conditions	MIN.	TYP.	MAX.	Unit	
Input	Forward voltage	$V_F$	$I_F = 8\text{mA}$	-	1.14	1.4	V	
	Reverse current	$I_R$	$V_R = 3\text{V}$	-	-	10.0	$\mu\text{A}$	
Output	Operating supply voltage	$V_{CC}$	-	4.5	-	17.0	V	
	Low level output voltage	$V_{OL}$	$V_{CC} = 5\text{V}, I_F = 0\text{mA}, I_{OL} = 16\text{mA}$	-	0.15	0.4	V	
	High level output voltage	$V_{OH}$	$V_{CC} = 5\text{V}, I_F = 8\text{mA}$	4.9	-	-	V	
	Low level supply current	$I_{CCL}$	$V_{CC} = 5\text{V}, I_F = 0\text{mA}$	-	1.7	3.8	mA	
	High level supply current	$I_{CCH}$	$V_{CC} = 5\text{V}, I_F = 8\text{mA}$	-	0.7	2.2	mA	
	Transfer characteristics	*1 "Low→High" threshold input current	$I_{FLH}$	$V_{CC} = 5\text{V}$	-	1.5	8.0	mA
*2 Hysteresis		$I_{FHL} / I_{FLH}$	$V_{CC} = 5\text{V}$	0.55	0.75	0.95	-	
Response time		"Low→High" propagation delay time	$t_{PLH}$	$V_{CE} = 5\text{V}, I_F = 8\text{mA}$ $R_L = 280\Omega$	-	3.0	9.0	$\mu\text{s}$
		"High→Low" propagation delay time	$t_{PHL}$		-	5.0	15.0	$\mu\text{s}$
		Rise time	$t_r$		-	0.1	0.5	$\mu\text{s}$
		Fall time	$t_f$		-	0.05	0.5	$\mu\text{s}$

\*1  $I_{FLH}$  represents forward current when output changes from low to high.\*2  $I_{FHL}$  represents forward current when output changes from high to low.

## Recommended Operating Conditions

Parameter	Symbol	Operating temperature range	MIN.	MAX.	Unit
Output current	$I_O$	Ta = 0 to + 70°C	-	16.0	mA
Forward current	$I_F$		10.0	20.0	mA

Fig. 1 Forward Current vs. Ambient Temperature

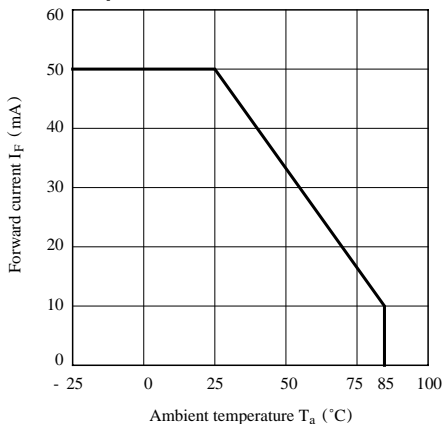
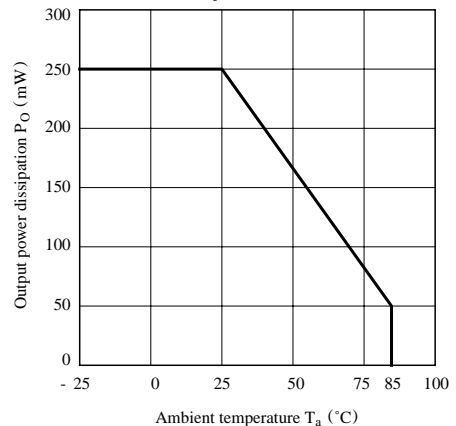
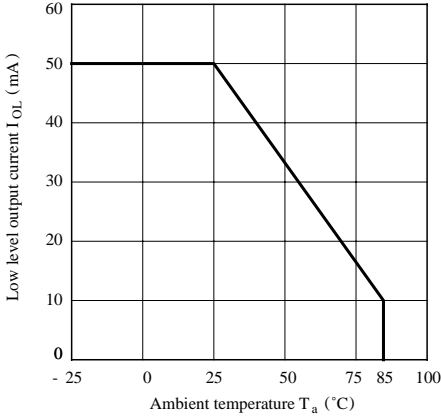

Fig. 2 Output Power Dissipation vs. Ambient Temperature



**Fig. 3 Low Level Output Current vs. Ambient Temperature**



**Fig. 4 Forward Current vs. Forward Voltage**

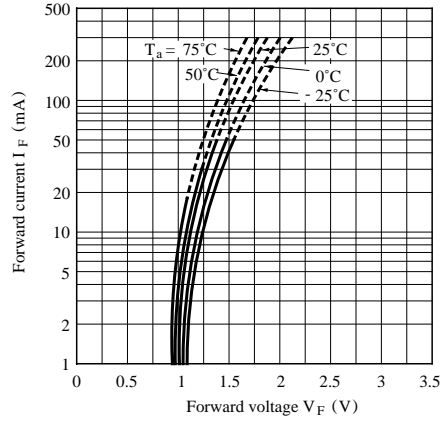

**Fig. 5 Relative Threshold Input Current vs. Supply Voltage**

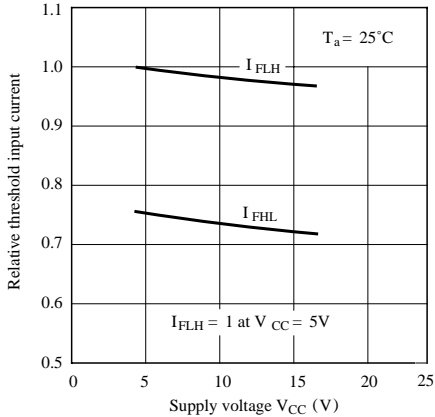

**Fig. 6 Relative Threshold Input Current vs. Ambient Temperature**

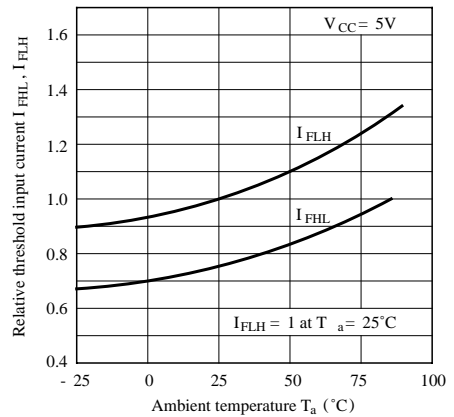

**Fig. 7 Low Level Output Voltage vs. Low Level Output Current**

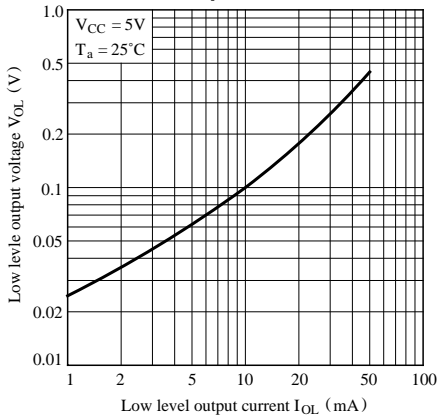

**Fig. 8 Low Level Output Voltage vs. Ambient Temperature**

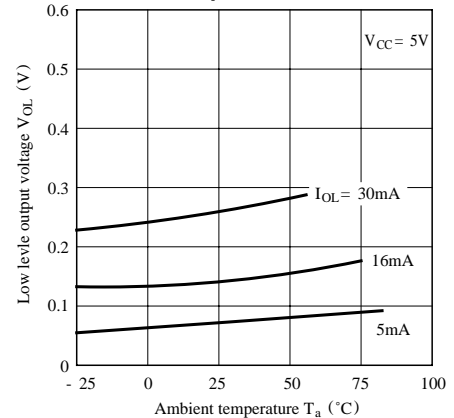

**Fig. 9 Supply Current vs. Ambient Temperature**

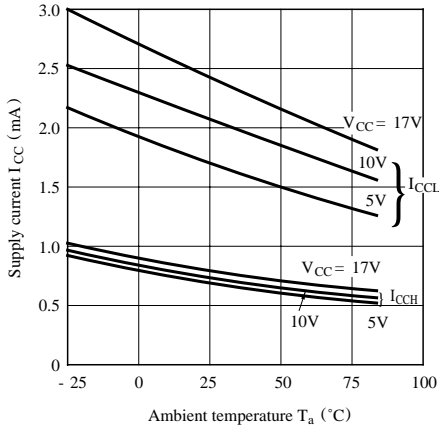

**Fig.10 Propagation Delay Time vs. Forward Current**

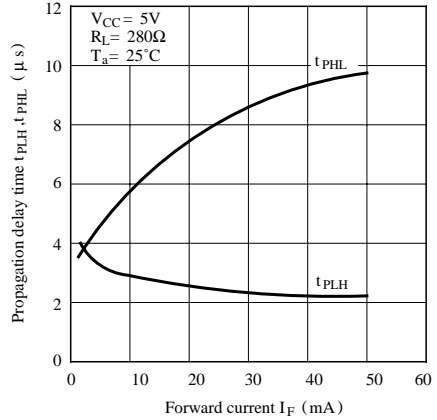

**Fig.11 Rise Time, Fall Time vs. Load Resistance**

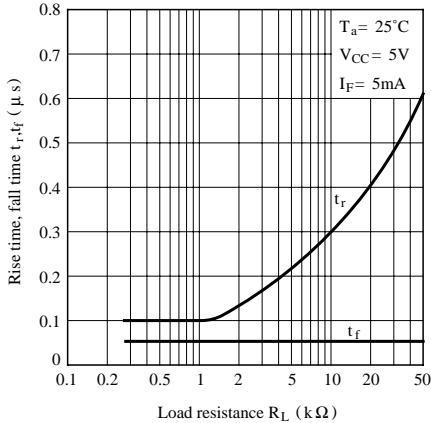

**Test Circuit for Response Time**

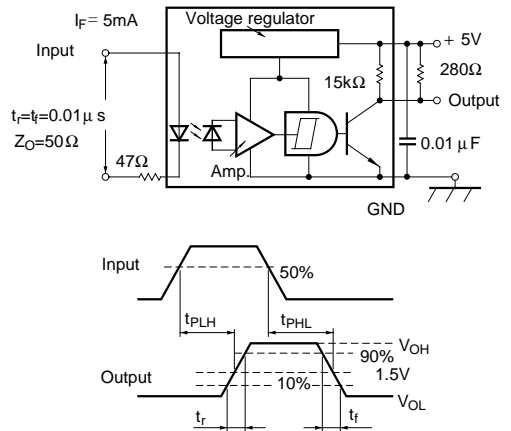

**■ Precautions for Use**

- (1) In order to stabilize power supply line, connect a by-pass capacitor of more than 0.01 µF between Vcc and GND near the device.
- (2) In case of cleaning, use only the following type of cleaning solvent.  
Ethyl alcohol, Methyl alcohol, Isopropyl alcohol
- (3) As for other general cautions, refer to the chapter “Precautions for Use”.