

Design Idea DI-85

LinkSwitch-LP[®] 2 W Charger: Replaces Unregulated Linear Solutions



Application	Device	Power Output	Input Voltage	Output Voltage	Topology
Charger	LNK564P	2 W	90-265 VAC	6 V	Flyback

Design Highlights

- Low-cost, low parts-count solution: 14-17 components
- Proprietary IC design and winding techniques enable a *Clampless*[™] design with simple *Filterfuse*[™] input stage
- $\pm 5\%$ over-temperature threshold – with hysteretic recovery – keeps PCB temperatures below safety limits
- Auto-restart: output short circuit and open loop protection
- IC creepage distance >3.2 mm: no arcing in high humidity
- Easily meets all EPS energy efficiency standards
- Meets CISPR-22 Class B EMI with good margin

Operation

This *LinkSwitch-LP* based flyback converter (Figure 1) provides an output VI curve (Figure 2) similar to that of an unregulated line frequency transformer based supply, but with output current that is limited past the maximum rated output power (peak power point).

From no-load to the 2 W peak power point, the LNK564P (U1) regulates the output voltage by skipping switching cycles, based on the current delivered into the FEEDBACK (FB) pin. At the peak power point, the supply delivers >300 mA of load current at >5.7 VDC.

Past the peak power point, cycle skipping ceases and U1 limits the supply's output current by reducing its oscillator (MOSFET switching) frequency, as the voltage on the FB pin drops. If the load demand causes the FB pin voltage to drop below an auto-restart threshold voltage $V_{FB(AR)}$ of 0.8 V (1 V to 1.5 V on the supply output) for more than 100 ms, the IC goes into auto-restart mode. In auto-restart, MOSFET switching is enabled for about 100 ms, approximately every 800 ms, until the FB pin voltage increases above 0.8 V.

Due to the frequency jittering of the U1 internal oscillator and the *E-Shield*[™] winding techniques used in constructing the transformer (T1), conducted EMI is adequately attenuated by the LC filter formed by L1 and C1. Inductor L1 serves as both a differential mode choke and a fuse. This *Filterfuse* is sleeved with heat-shrink tubing, and its winding wire diameter was selected so that it will open like a fuse if any single component fails shorted. Thanks to the tight current limit tolerance of the *LinkSwitch-LP* family and construction techniques used on T1, the primary winding can be left *Clampless*, since the peak drain voltage does not approach the 700 V drain-to-source breakdown voltage (BV_{DSS}) of U1.

With no optocoupler and such a low parts count, this supply is cost competitive with the unregulated line frequency transformer based solution it was designed to replace.

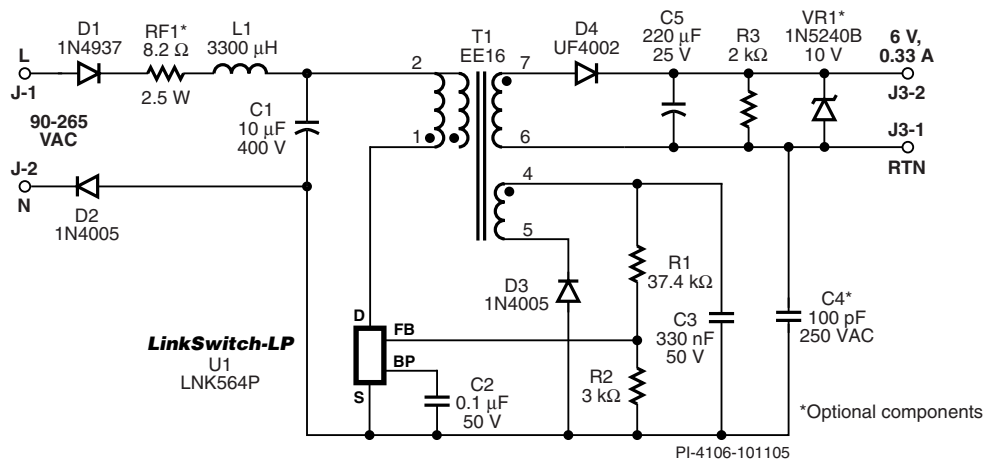

Figure 1. LNK564 Based 6 V, 330 mA, 2 W, Low-Cost, Flyback Charger Power Supply.

Key Design Points

- The *PI Xls* spreadsheet calculates all of the parameters required to specify and build transformer T1.
- This design uses one of two “standard” transformers (see AN-39). With this transformer, the output voltage of the supply can be set between 4 V and 7.5 V by selecting the appropriate value of R1.
- Figure 1 contains three optional components: RF1, VR1 and C4. A fusible resistor must be used if a safety agency disapproves of using L1 as a fusible component. The auto-restart function limits the output power during open loop operation, so only a 1/2 W VR1 is required if the open loop output voltage is unacceptable. Y capacitor C4 improves EMI repeatability but is not required to meet EMI limits.
- For the IC to limit the supply’s output current past the point of peak power delivery, the voltage on the FB pin must begin to drop below 1.69 V as the load increases. Therefore, the value of R1 should be selected so the FB pin voltage is 1.69 V at the peak power point.

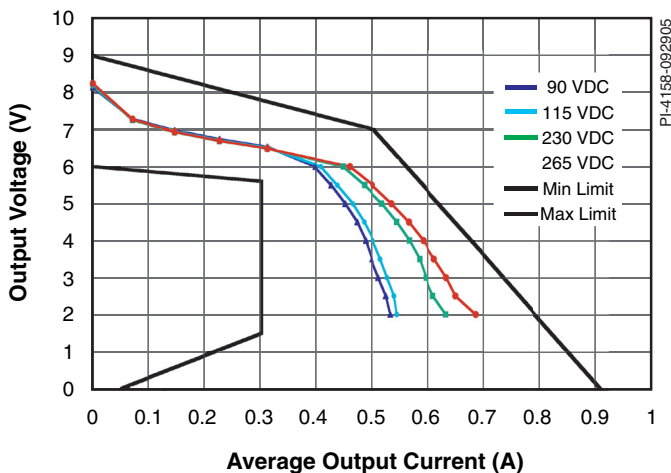

Figure 2. Output VI Characteristic Curves vs. Load & Line

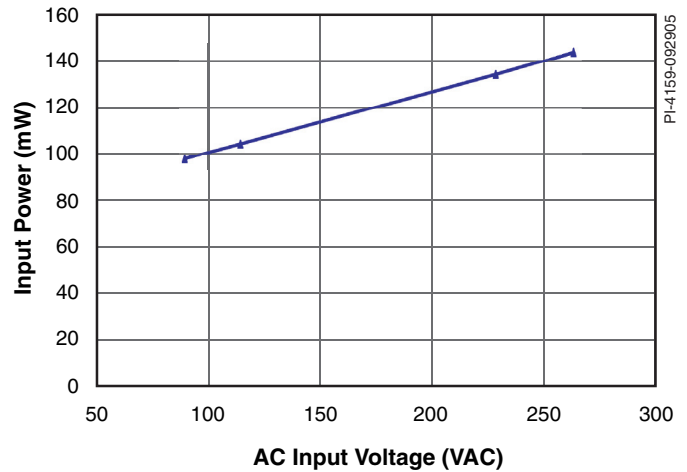

Figure 3. No-load Input Power vs. Line Voltage.

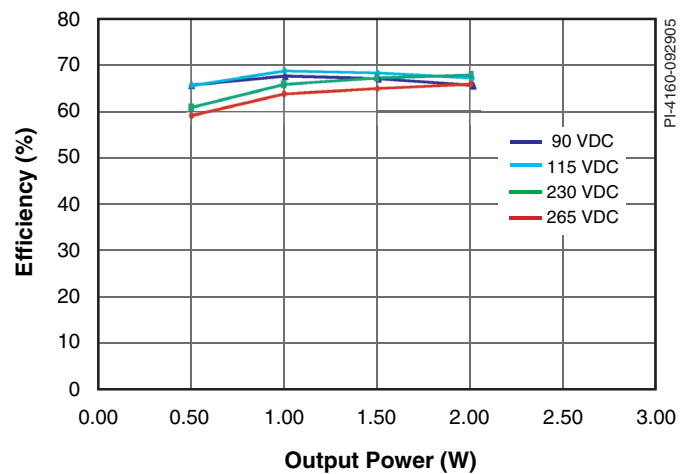

Figure 4. Efficiency vs. Output Power and Line Voltage.

For the latest updates, visit www.powerint.com

Power Integrations reserves the right to make changes to its products at any time to improve reliability or manufacturability. Power Integrations does not assume any liability arising from the use of any device or circuit described herein. POWER INTEGRATIONS MAKES NO WARRANTY HEREIN AND SPECIFICALLY DISCLAIMS ALL WARRANTIES INCLUDING, WITHOUT LIMITATION, THE IMPLIED WARRANTIES OF MERCHANTABILITY, FITNESS FOR A PARTICULAR PURPOSE, AND NON-INFRINGEMENT OF THIRD PARTY RIGHTS. The products and applications illustrated herein (transformer construction and circuits external to the products) may be covered by one or more U.S. and foreign patents or potentially by pending U.S. and foreign patent applications assigned to Power Integrations. A complete list of Power Integrations’ patents may be found at www.powerint.com. Power Integrations grants its customers a license under certain patent rights as set forth at <http://www.powerint.com/ip.htm>.

The PI logo, **TOPSwitch**, **TinySwitch**, **LinkSwitch**, **DPA-Switch**, **EcoSmart**, **Clampless**, **E-Shield**, **Filterfuse**, **PI Expert** and **PI FACTS** are trademarks of Power Integrations, Inc. Other trademarks are property of their respective companies. ©Copyright 2005, Power Integrations, Inc.

Power Integrations		5245 Hellyer Avenue		San Jose, California 95138	
MAIN PHONE NUMBER	APPLICATIONS HOTLINE	APPLICATIONS FAX			
+1 408-414-9200	+1 408-414-9660	+1 408-414-9760	For a complete listing of worldwide sales offices, please visit www.powerint.com		

