

LinkSwitch-TN[®]

LED Driver for Halogen Light Bulb Retrofit

Application	Device	Power Output	Input Voltage	Output Voltage	Topology
LED Lighting	LNK306DN	3 W	85-265 VAC	10 V _{TYP} (9-15 V), 300 mA	Non-isolated Buck

Design Highlights

- Fits inside standard GU10 lamp base
- Constant current (CC) output
 - Drive current independent of LED V_F variations
 - Tight line regulation ($\pm 5\%$) for constant light output
 - No annoying line frequency flicker
- Universal input voltage range
 - A single design can be sold worldwide
 - Consistently high efficiency across entire range
- Meets EN55022 B conducted EMI limits
- Complete overvoltage and over temperature protection
 - Operates unloaded: can be tested without the LEDs
 - Auto-restart: withstands shorted output indefinitely
 - Thermal shutdown: protects entire lamp assembly

Operation

The non-isolated buck converter shown in Figure 1 was designed around a member of the LinkSwitch-TN IC family, the LNK306DN (U1). A LNK306 was selected since its minimum current limit (450 mA) ensures that it will be able to deliver the required 330 mA of output current.

Diode bridge BR1 rectifies the AC input while capacitors C1 and C2 filter it. Inductor L1 and RF1 attenuate conducted EMI. In case of a component failure, RF1 will act as a fuse.

The MOSFET within U1, diode D3, inductor L2 and capacitor C3 form the buck converter stage. The controller within U1 regulates the output current by enabling and disabling MOSFET switching cycles.

During normal operation, the output current develops a voltage drop across R8 and R10, which is impressed across C6. When the voltage across C6 exceeds the V_{BE} of Q1, Q1 and Q2 both turn on. When Q2 turns on, current is injected into the FEEDBACK (FB) pin of U1 from C5, via R3. Whenever the current into the FB pin exceeds 49 μA , MOSFET switching is disabled. The controller adjusts the ratio of enabled and disabled cycles to regulate the output current at 330 mA.

During no-load operation, the output voltage is sensed by D1, D2 and C2. The voltage across C5 feeds current into the FB pin of U1 through divider R7 and R1. The FB pin

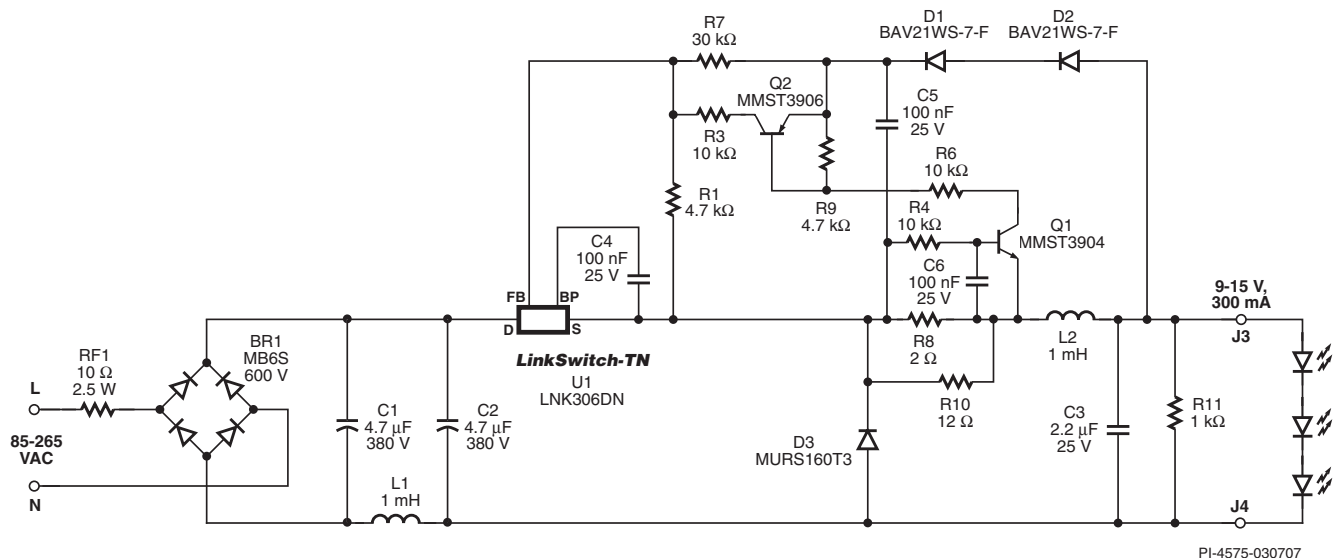

Figure 1. 3 W LED, Halogen Bulb Replacement using LinkSwitch-TN in Non-Isolated Buck Converter Technology.

voltage is specified as 1.63 V at 49 μ A, which allows it to be used as a reference. The output voltage is regulated to <18 V by disabling MOSFET switching cycles as the current into the FB pin exceeds 49 μ A.

Key Design Points

- To prevent EMI coupling between the switching nodes on the main board and the input filter board, a shield board (connected to C2 negative) was placed between the two PC boards (see Figure 3). This greatly improved the margin to the conducted EMI limits.
- Diodes D1 and D2 can be replaced by a single 600 V diode. Two 250 V diodes were used because they took up less space than a single 600 V diode.
- Increasing the value of C3 will reduce the ripple current through the LED load at the expense of increased component size and cost.
- Pre-load resistor R11 ensures correct no-load operation, which enables the power supply to be tested without the load connected to it.
- Verify that L2 does not saturate heavily at the maximum current limit of U1 (647 mA). Refer to the Inductor Manufacturer's $L - 20\%$ current rating.
- In less thermally challenged enclosures, the FB pin can be used to directly sense the voltage across resistors R8 and R10. This can eliminate Q1, Q2 and associated components, but requires the current limit sense voltage to increase from 0.65 V to 1.65 V. This will increase the sense resistor dissipation by about 300 mW and cause the internal ambient temperature of the supply to increase.
- Maximize the PCB area that the U1 SOURCE pins connect to, for optimal heatsinking.
- Since this design does not provide input to output isolation, the load LEDs must be isolated from the user via the light bulb enclosure.

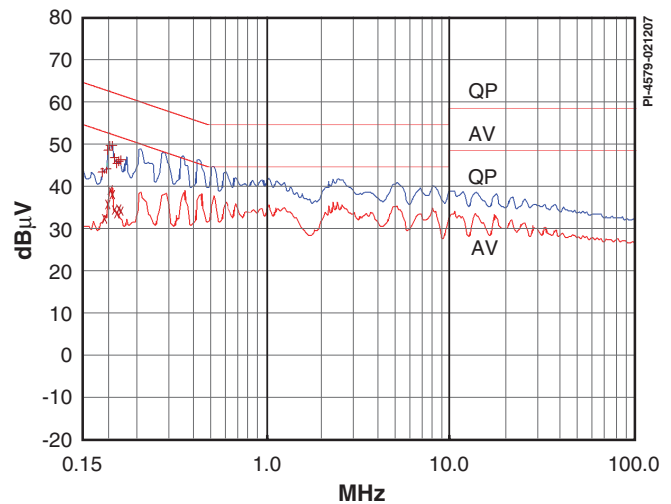

Figure 2. Worst Case Conducted EMI (230 VAC).

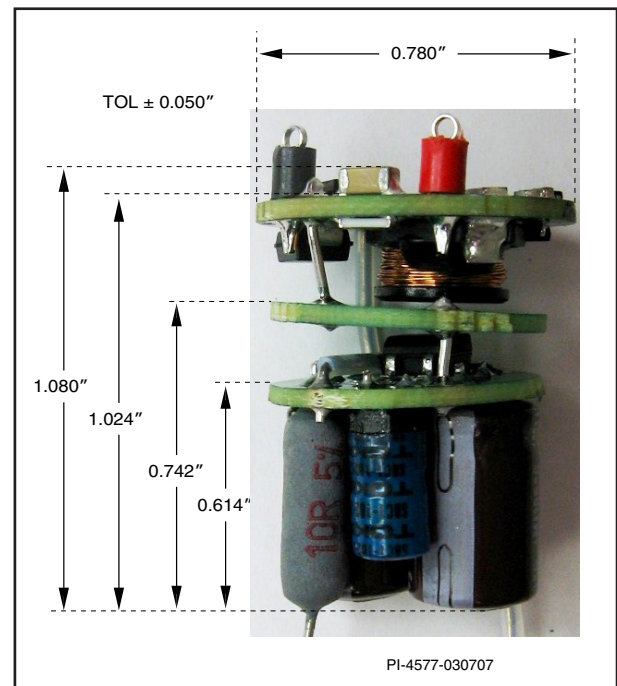

Figure 3. Assembled Unit, Dimensions: 0.78 × 1 inch (19.8 × 25.4 mm).

For the latest updates, visit www.powerint.com

Power Integrations reserves the right to make changes to its products at any time to improve reliability or manufacturability. Power Integrations does not assume any liability arising from the use of any device or circuit described herein. POWER INTEGRATIONS MAKES NO WARRANTY HEREIN AND SPECIFICALLY DISCLAIMS ALL WARRANTIES INCLUDING, WITHOUT LIMITATION, THE IMPLIED WARRANTIES OF MERCHANTABILITY, FITNESS FOR A PARTICULAR PURPOSE, AND NON-INFRINGEMENT OF THIRD PARTY RIGHTS. The products and applications illustrated herein (transformer construction and circuits external to the products) may be covered by one or more U.S. and foreign patents or potentially by pending U.S. and foreign patent applications assigned to Power Integrations. A complete list of Power Integrations' patents may be found at www.powerint.com. Power Integrations grants its customers a license under certain patent rights as set forth at <http://www.powerint.com/ip.htm>.

The PI logo, **TOPSwitch**, **TinySwitch**, **LinkSwitch**, **DPA-Switch**, **PeakSwitch**, **EcoSmart**, **Clampless**, **E-Shield**, **Filterfuse**, **StackFET**, **PI Expert** and **PI FACTS** are trademarks of Power Integrations, Inc. Other trademarks are property of their respective companies. ©2007, Power Integrations, Inc.

Power Integrations
5245 Hellyer Avenue
San Jose, CA 95138
Phone: 1-408-414-9200
Apps: 1-408-414-9660
Apps Fax: 1-408-414-9760

For a complete listing of worldwide sales offices, please visit www.powerint.com