

CSM-7-DN Extended Temp Range Crystal



The CSM-7-DN is the extended temp range version of our standard HC-49US SMD crystal. The DN version has an operating temperature of -40 to +85°C and a frequency stability of ± 100 ppm. The CSM-7-DN is a low cost option for today's industrial applications.

FEATURES

- Cost effective
- Resistance-weld sealing
- Extended Temp range
- SMD

PART NUMBERING GUIDE "EXAMPLE"

ECS	-	FREQUENCY (4.000 MHz)	-	LOAD CAPACITANCE*	-	PACKAGE TYPE **	-	Suffix
ECS	-	40	-	20	-	5P	-	DN

* Load Capacitance (xx=xx pF, S=series resonance) ** Package Type examples (-5P=4.3 mm max. height, -5PL = 3.2 mm max. height)
DN Suffix, D= ± 100 ppm frequency stability, N = -40 to +85°C temp range

OPERATING CONDITIONS/ELECTRICAL CHARACTERISTICS

PARAMETERS	CONDITIONS	MINIMUM	TYPICAL	MAXIMUM	UNITS
FREQUENCY RANGE		3.579545		70.000	MHz
CALIBRATION TOLERANCE	@ +25°C			± 30	PPM
FREQUENCY STABILITY, ref @25°C	-40 ~ +85°C			± 100	PPM
SHUNT CAPACITANCE				7	pF
LOAD CAPACITANCE	CL (Customer Specified)	10	20.0 std	Series	pF
DRIVE LEVEL	DL			500	μ W
OPERATING TEMPERATURE	T _{OPR}	-40		+85	°C
STORAGE TEMPERATURE	T _{STG}	-40		+105	°C
AGING CHARACTERISTICS (Per Year)	@ +25°C ± 3 °C per year			± 5	PPM

EQUIVALENT SERIES RESISTANCE / MODE OF OSCILLATION

FREQUENCY RANGE (MHz)	MODE OF OSC.	MAX. ESR (W)	FREQUENCY RANGE (MHz)	MODE OF OSC.	MAX. ESR (W)
3.579545 - 4.999	Fundamental	150	13.000 - 19.999	Fundamental	40
5.000 - 5.999	Fundamental	80	20.000 - 29.000	Fundamental	30
6.000 - 6.999	Fundamental	70	26.000 - 39.999	3rd O/T	100
7.000 - 8.999	Fundamental	60	40.000 - 70.000	3rd O/T	80
9.000 - 12.999	Fundamental	50			

PACKAGE DIMENSIONS (mm)

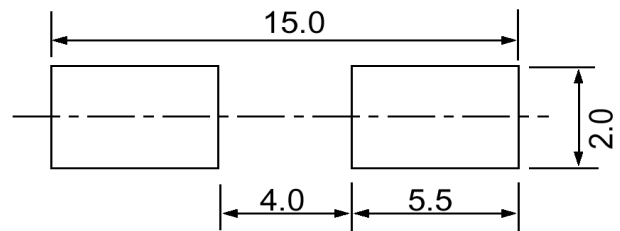
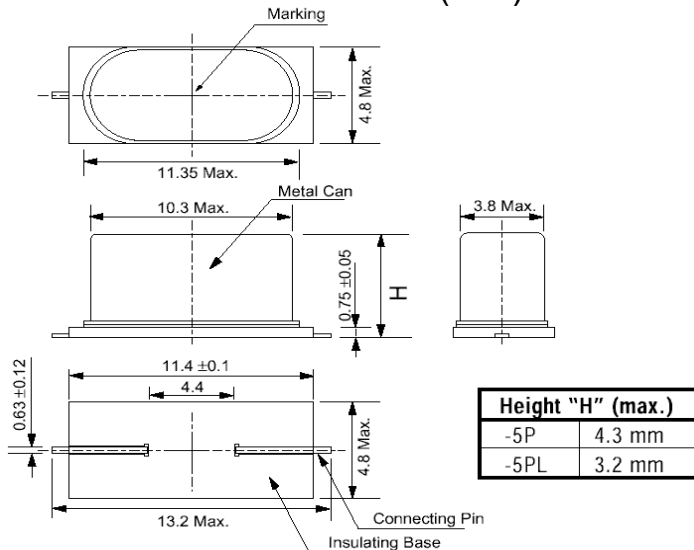

Figure 1) CSM-7-DN - Top, Side, Bottom and End Views

Figure 2) CSM-7-DN Land Pattern