



Advanced Product Information  
September 1996 (1 of 2)

## 824 to 928 MHz 3V, 30.5 dBm Multi-Mode Power Amplifier

### Features

- ❑ Multi-Mode Operation from 3V Supply
- ❑ 40% Linear Power Added Efficiency
- ❑ 30 dBm with 55% Power Added Efficiency
- ❑ Low Cost, SO-8 Surface Mount Package
- ❑ 39 dB Gain
- ❑ Tested Under Digital Modulation

### Applications

- ❑ IS-136/AMPS Cellular Handsets
- ❑ 900 MHz ISM Band Products
- ❑ Wireless Local Loop Subscriber Terminals

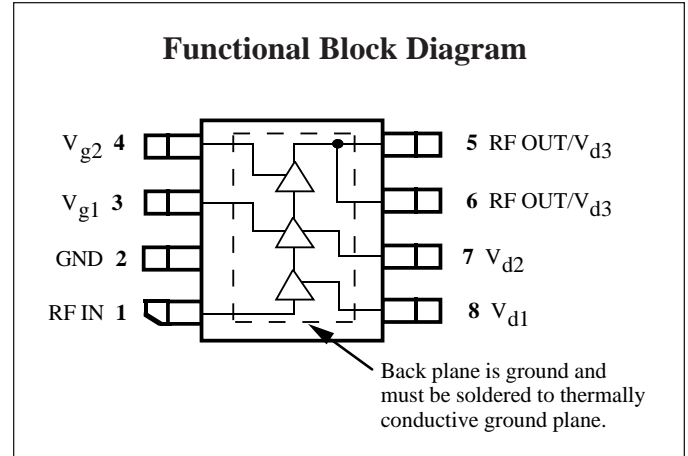

### Description

The CMM0330 is a highly efficient 3 V, multi-mode power amplifier intended for use in portable cellular handsets and datacom products operating in the AMPS and 902-928 MHz bands. As a pin-compatible member of the new **Triniti DX™** amplifier family, the CMM0330 offers maximum performance

and flexibility. The CMM0330 is packaged in a low-cost, space efficient SO-8 power package that gives excellent electrical stability and thermal handling performance with a  $R_{\theta}$  of less than 18° C/W. The part is designed to require minimal external circuitry for bias matching, simplifying design and keeping board space and cost to a minimum.

### Absolute Maximum Ratings

Parameter	Rating	Parameter	Rating	Parameter	Rating
Drain Voltage (+V <sub>d</sub> )	+9.0 V*	Power Dissipation	5 W	Operating Temperature	-40°C to +100°C
Drain Current (I <sub>d</sub> )	1.8 A	Thermal Resistance	18°C/W	Channel Temperature	175°C
RF Input Power	+15 dBm*	Storage Temperature	-65°C to +150°C	Soldering Temperature	260°C for 5 Sec.
DC Gate Voltage (-V <sub>g</sub> )	-4.0 V*				

\* Max (+V<sub>d</sub>) and (-V<sub>g</sub>) under linear operation. Max potential difference across the device in RF compression (2V<sub>d</sub> + |-V<sub>g</sub>|) not to exceed the minimum breakdown voltage (V<sub>br</sub>) of +18V.

### Recommended Operating Conditions

Parameter	Typ	Units	Parameter	Typ	Units
Drain Voltage (+V <sub>d</sub> )	3.0 to 4.0	Volts	Operating Temperature (PC Board)	-30 to +80	°C

### Electrical Characteristics

Unless otherwise specified the following specifications are guaranteed at room temperature with drain voltage (+V<sub>d</sub>) = 3.6 V, in Celeritek test fixture.

Parameter	Condition	Digital Bias			Analog Bias			Units
		Min	Typ	Max	Min	Typ	Max	
Frequency Range		824		928	824		928	MHz
Pout - Digital Operation	Meets IS-136 TDMA mask	28.5	30.0					dBm
Pout - Analog Operation	AMPS				30.0	30.5		dBm
Efficiency	Digital cellular operation	35	40		50	55		%
Gain		36	39		36	39		dB
Harmonics	2nd @ Pout = +30.5 dBm 3rd @ Pout = +30.5 dBm						-30 -30	dBc dBc
Return Loss	In Celeritek test fixture		10			10		dB
Negative Supply Current				1			3	mA
Supply Current			500			500		mA
Quiescent Current	No RF		450			450		mA

## Connection Diagram and Pin Descriptions

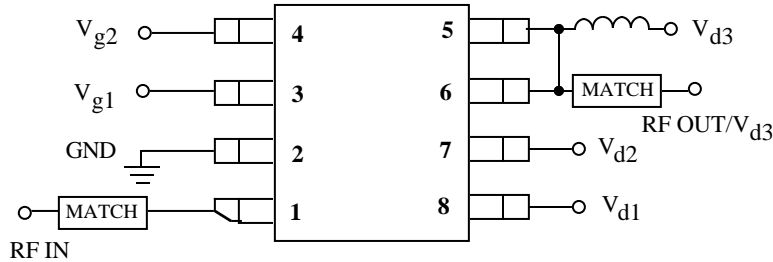

Pin #	Name	Description
1	RF IN	RF input
2	GND	Ground
3	V <sub>g1</sub>	Input stage gate bias
4	V <sub>g2</sub>	Output stage gate bias
5	RF OUT/V <sub>d3</sub>	RF output and V <sub>d3</sub> . External matching circuit required
6	RF OUT/V <sub>d3</sub>	RF output and V <sub>d3</sub> . External matching circuit required
7	V <sub>d2</sub>	Second input stage drain bias
8	V <sub>d1</sub>	Input stage drain bias

## Physical Dimensions

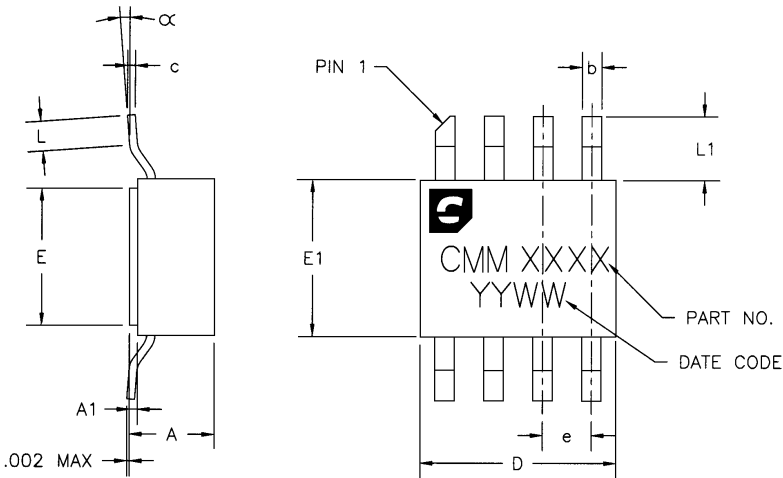

DIMENSION	MINIMUM	NOMINAL	MAXIMUM
A		.086[2.184]	.100[2.540]
A1	.005[.1270]	.008[.2032]	.011[.2794]
b	.017[.4318]	.020[.5080]	.023[.5842]
c	.007[.1778]	.008[.2032]	.009[.2286]
D	.195[4.953]	.200[5.080]	.205[5.207]
E	.135[3.429]	.140[3.556]	.145[3.683]
E1	.155[3.937]	.160[4.064]	.165[4.191]
e		.050[1.270]	
L	.020[.5080]		.040[1.016]
L1	.055[1.397]	.065[1.651]	.075[1.905]
α	0°		8°

DIMENSIONS IN INCHES [MILLIMETERS]

## Ordering Information

The CMM0330 is available in a surface mount SO-8 power package and devices are available in tape and reel.

### Part Number for Ordering

CMM0330-AK  
CMM0330-AK-000T

### Package

SO-8 surface mount power package  
SO-8 surface mount power package in tape and reel

Celeritek reserves the right to make changes without further notice to any products herein. Celeritek makes no warranty, representation or guarantee regarding the suitability of its products for any particular purpose, nor does Celeritek assume any liability arising out of the application or use of any product or circuit, and specifically disclaims any and all liability, including without limitation consequential or incidental damages. "Typical" parameters can and do vary in different applications. All operating parameters, including "Typicals" must be validated for each customer application by customer's technical experts. Celeritek does not convey any license under its patent rights nor the rights of others. Celeritek products are not designed, intended, or authorized for use as components in systems intended for surgical implant into the body, or other applications intended to support or sustain life, or for any other application in which the failure of the Celeritek product could create a situation where personal injury or death may occur. Should Buyer purchase or use Celeritek products for any such unintended or unauthorized application, Buyer shall indemnify and hold Celeritek and its officers, employees, subsidiaries, affiliates, and distributors harmless against all claims, costs, damages, and expenses, and reasonable attorney fees arising out of, directly or indirectly, any claim of personal injury or death associated with such unintended or unauthorized use, even if such claim alleges that Celeritek was negligent regarding the design or manufacture of the part. Celeritek is a registered trademark of Celeritek, Inc. Celeritek, Inc. is an Equal Opportunity/Affirmative Action Employer.