

Charge Pump White LED Driver

Features

- 3.0V to 6.5V input voltage range
- Dual mode operation: 1x and 1.5x
- Fixed 4.5V output with initial accuracy of $\pm 2\%$
- Supports up to 180mA (@4V) output
- High efficiency at both high and low input voltages
- Low external parts count, requires no inductor
- PWM brightness control via the ENA pin
- Selectable 8kHz, 32kHz, 262kHz, and 650kHz switching frequency
- Low shutdown current of $<1\mu\text{A}$
- Soft start prevents excessive inrush current
- Over-temperature and over-current protection
- Low output ripple ($<1\%$), low EMI
- Input protection provides superior ESD rating requiring only standard handling precautions
- TDFN-10 or MSOP-10 package
- Optional RoHS compliant lead free packaging

Applications

- Drives white LEDs to backlight color LCDs
- Drives white or RGB LEDs for camera flash
- Cellular phones
- MP3 players
- PDAs, GPS

Product Description

The CM9156A is an efficient, 1.5x switched capacitor (charge pump) regulator ideal for white LED applications. It has a regulated 4.5V, 120mA output, capable of driving up to six parallel white LEDs. With a typical operating input voltage range from 3.0V to 6.0V, the CM9156A can be operated from a single-cell Li-Ion battery.

It features an efficient, 1.5x charge pump circuit that uses only two 1.0 μF ceramic bucket capacitors and two small capacitors for VIN and VOUT. The CM9156A offers a selectable switching frequency of 8kHz, 32kHz, 262kHz, or 650kHz. The LED brightness can be adjusted by applying a PWM signal on the ENA pin.

The CM9156A output voltage is regulated to 4.5V, $\pm 5\%$ over the line and load ranges. Up to 180mA of output current is available. The proprietary design architecture maintains high efficiency ($> 80\%$), and at low V_{IN} provides longer battery life. With a high V_{IN} , or when the adapter is powered, it provides cool reliable operation. It offers low output voltage ripple, typically less than 50mV. Internal over-temperature and over-current management provide short circuit protection.

The CM9156A is packaged in either a space saving 10-Lead TDFN or 10-Lead MSOP package. It can operate over the industrial temperature range of -25°C to 85°C .

Typical Application

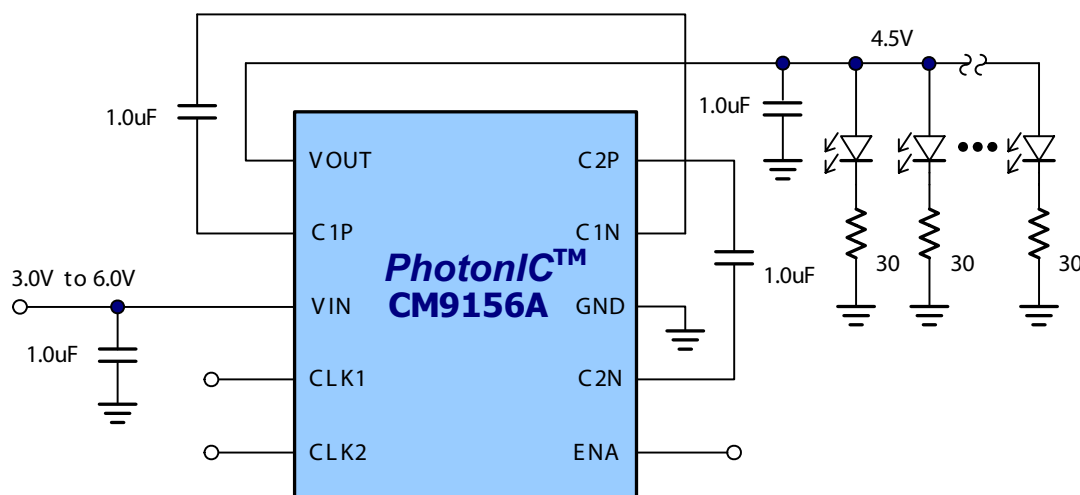

Package Pinout

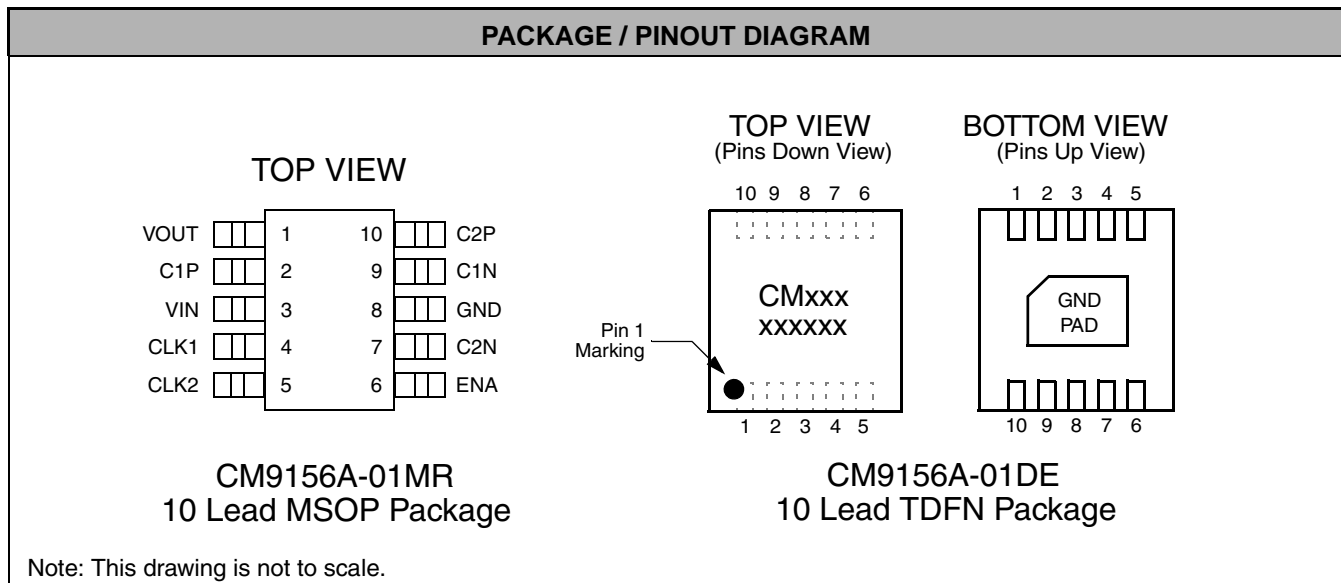

Ordering Information

PART NUMBERING INFORMATION			
Pins	Package	Lead-free Finish	
		Ordering Part Number ¹	Part Marking
10	TDFN	CM9156A-01DE	
10	MSOP	CM9156A-01MR	

Note 1: Parts are shipped in Tape & Reel form unless otherwise specified.

Specifications

ABSOLUTE MAXIMUM RATINGS		
PARAMETER	RATING	UNITS
ESD Protection (HBM)	± 2	kV
VIN to GND	[GND - 0.3] to +6.5	V
Pin Voltages		
V _{OUT} to GND	[GND - 0.3] to +6.0	V
C1P, C1N to GND	[GND - 0.3] to +4.5	V
C2P, C2N to GND	[GND - 0.3] to +4.5	V
ENA, CLK1, CLK2 to GND	[GND - 0.3] to +6.0	V
Storage Temperature Range	-65 to +150	°C
Operating Temperature Range	-40 to +85	°C
Lead Temperature (Soldering, 10s)	300	°C

Specifications (cont'd)

ELECTRICAL OPERATING CHARACTERISTICS						
VIN = 3.6V. Typical values are at TA = 25 °C						
SYMBOL	PARAMETER	CONDITIONS	MIN	TYP	MAX	UNIT
V _{IN}	VIN Supply Voltage		3.0		6.0	V
I _{SD}	Shut-Down Supply Current	ENA = 0		1		μA
I _Q	Quiescent Current	Fs = 8 kHz		250	380	μA
		Fs = 32 kHz		280	470	μA
		Fs = 262 kHz		800	1200	μA
		Fs = 650 kHz		1600	2500	μA
Charge Pump Circuit						
V _{R LOAD}	Load Regulation	Fs = 262 kHz or 650 kHz, I _{out} = 0 mA to 120 mA, Vin = 3.2V to 6.5V	4.2	4.5	4.7	V
		I _{out} = 0 mA to 90 mA, Vin = 3.0V to 3.2V	4.0	4.1	4.2	V
V _{R LIN}	Line Regulation	Fs = 262 kHz or 650 kHz, I _{out} = 60 mA, Vin = 3.2V to 6.5V	4.4	4.5	4.6	V
		Vin = 3.0V to 3.2V	4.0	4.1	4.3	V
I _{OUT}	Output Current	V _{out} = 4.5V			120	mA
		V _{out} = 4.0V			180	mA
V _{OUTR}	Output Ripple Voltage	Fs = 262 kHz, I _{out} = 60 mA		50		mV
fs	Switching Frequency	CLK1 = 0, CLK2 = 0		32.8		kHz
		CLK1 = 1, CLK2 = 0		8.2		kHz
		CLK1 = 0, CLK2 = 1		262		kHz
		CLK1 = 1, CLK2 = 1		650		kHz
CLK1, CLK2						
	High Level Input Voltage		1.2			V
	Low Level Input Voltage				0.6	V
ENA						
V _{IH}	High Level Input Voltage		1.3			V
V _{IL}	Low Level Input Voltage				0.4	V
Protection						
I _{LIM}	Over-current Limit			400	600	mA
T _{JSD}	Over-temperature Limit			135		°C
T _{HYS}	Over-temperature Hysteresis			15		°C

Typical Performance Curves

$C_{IN}=C_{OUT}=C_1=C_2=1.0\mu F$, $T_A=25^\circ C$, unless specified otherwise

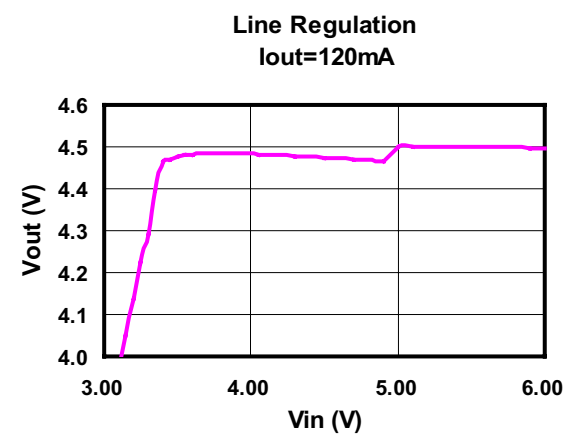
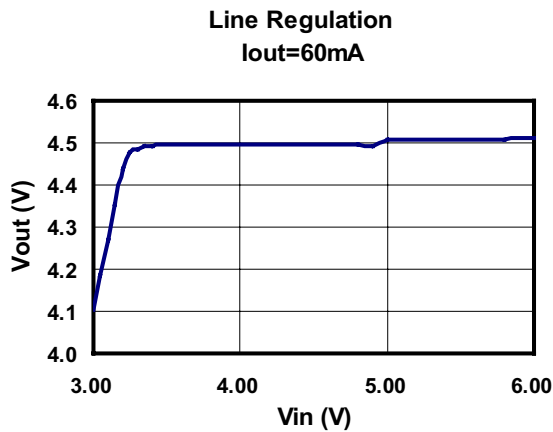
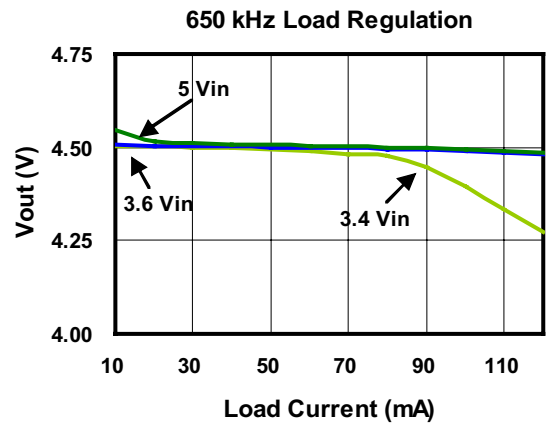
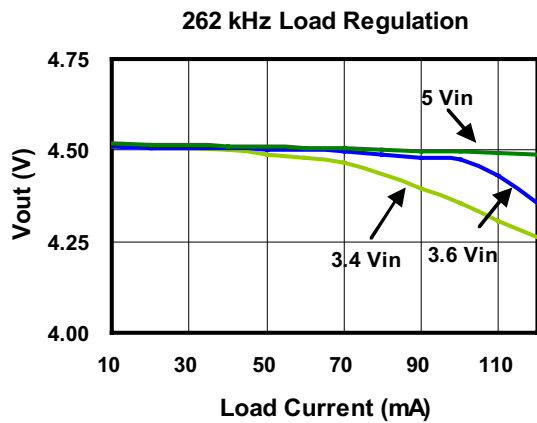
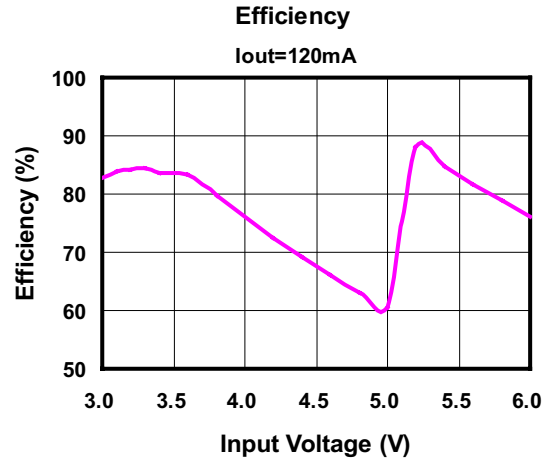
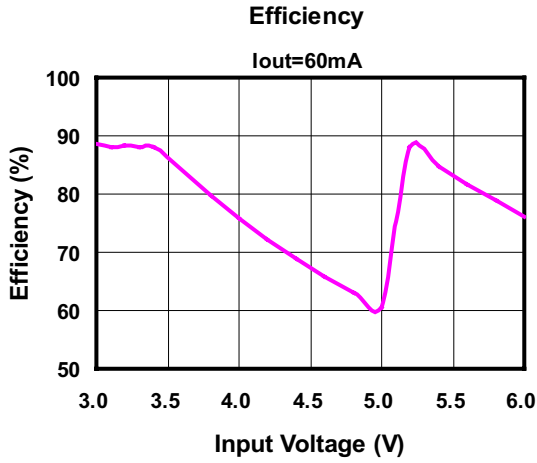

Typical Performance Curves (cont'd)

$C_{IN}=C_{OUT}=C_1=C_2=1.0\mu F$, $T_A=25^\circ C$, unless specified otherwise

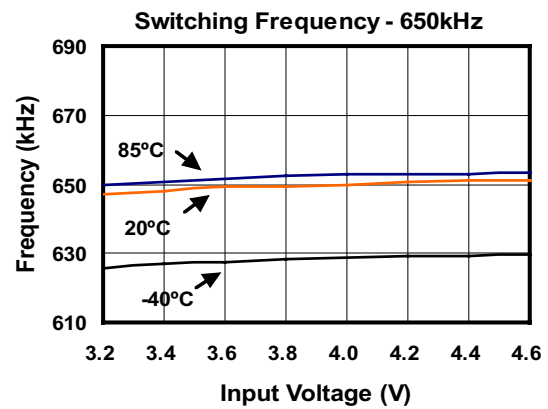
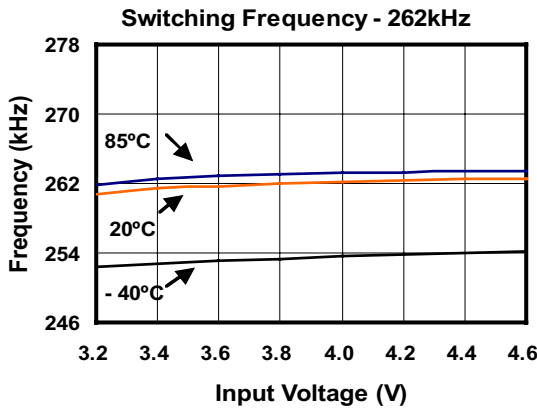
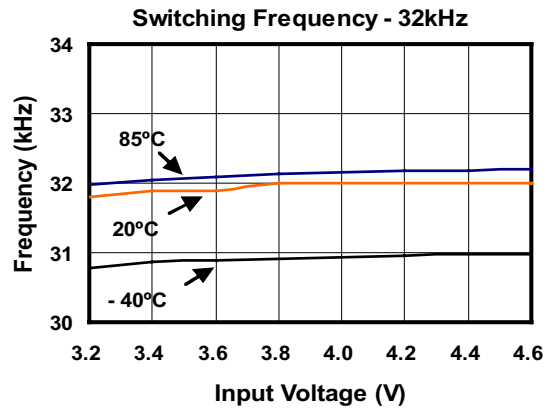
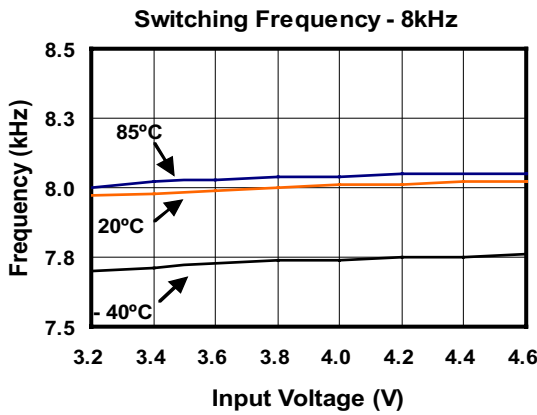
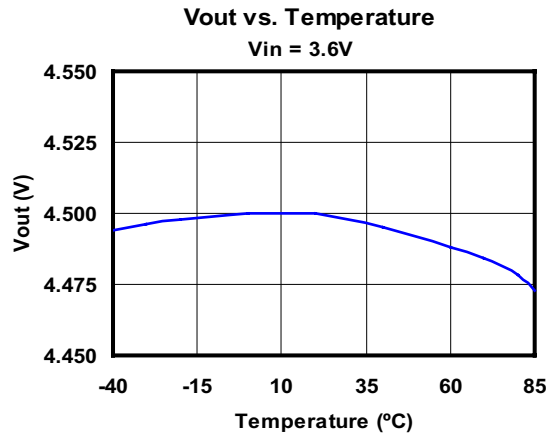
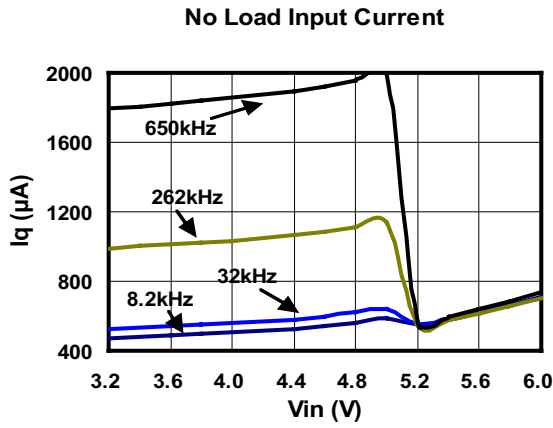

Typical Performance Curves (cont'd)

$C_{IN}=C_{OUT}=C_1=C_2=1.0\mu F$, $T_A=25^\circ C$, unless specified otherwise

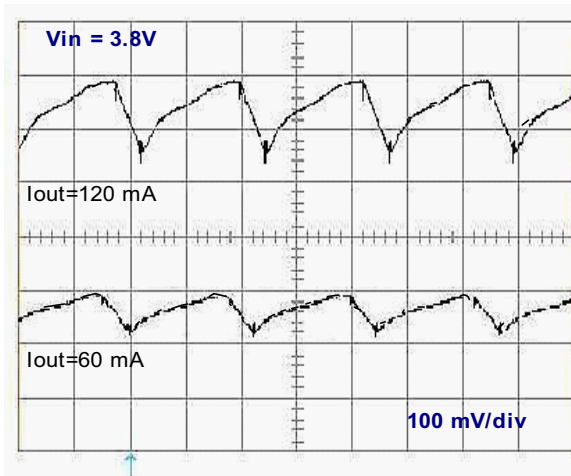

Output Ripple, 262 kHz

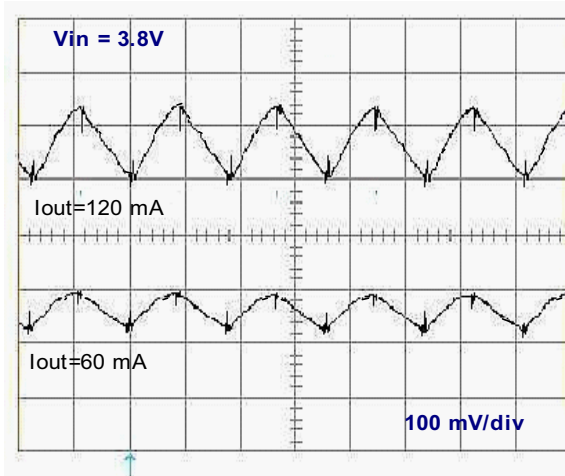

Output Ripple, 650 kHz

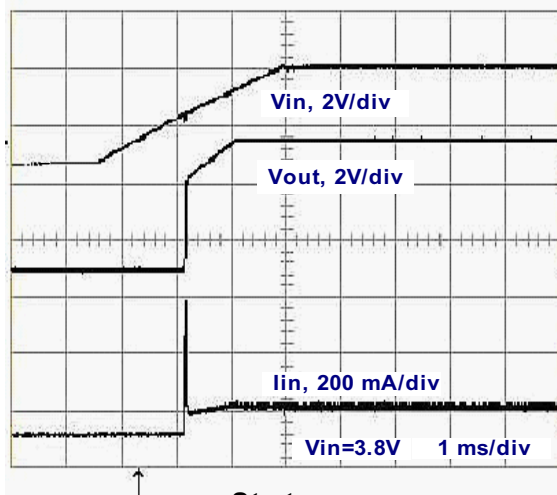

Startup

Frequency Selection Table

Switching Frequency	CLK1	CLK2
8kHz	1	0
32kHz	0	0
262kHz	0	1
650kHz	1	1

Table 1: Frequency Selection

Functional Block Diagram

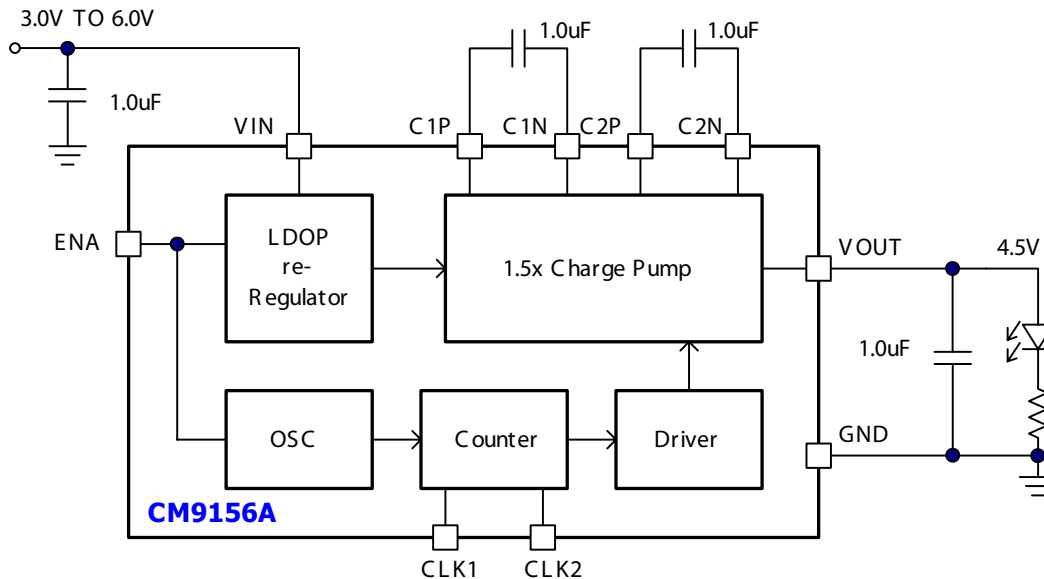

Pin Discriptions

PIN DESCRIPTIONS		
LEAD(s)	NAME	DESCRIPTION
1	VOUT	The regulated 4.5V output voltage pin. This pin requires a 1.0µF or larger ceramic capacitor to ground. This pin connects to the anodes of the LEDs.
2	C1P	This pin is the plus side of charge pump bucket capacitor C1. Connect a 1.0µF ceramic capacitor with a voltage rating of 10V or greater between C1N and C1P.
3	VIN	Positive supply voltage input pin. This voltage should be between 3.0V and 6V. This pin requires a 1.0µF or larger ceramic capacitor to ground.
4	CLK1	Bit 1 for setting switching frequency (see Table 1)
5	CLK2	Bit 2 for setting switching frequency (see Table 1)
6	ENA	Enable pin, active high. By applying a PWM signal to this pin, the LED brightness can be controlled.
7	C2N	This pin is the minus side of charge pump bucket capacitor C2. Connect a 1.0µF ceramic capacitor between C2N and C2P.
8	GND	Ground pin.
9	C1N	This pin is the minus side of charge pump bucket capacitor C1. Connect a 1.0µF ceramic capacitor between C1N and C1P.
10	C2P	This pin is the plus side of charge pump bucket capacitor C2. Connect a 1.0µF ceramic capacitor between C2N and C2P.

Application Information

The CM9156A is a switched capacitor charge pump voltage converter ideally suited for driving white LEDs to backlight or sidelight LCD color displays for portable devices such as cellular phones, PDAs and any application where small space and efficiency are critical. The CM9156A charge pump is the perfect driver for such portable applications, providing efficiency, compact overall size, low system cost and minimal EMI.

The CM9156A contains a linear low dropout (LDO) regulator followed by a 1.5x fractional charge pump that converts the nominal lithium-ion (Li-Ion) or lithium polymer battery voltage levels (3.6V) by a gain of 1.5 times and regulates the converted voltage to 4.5V, ± 5%, enough to drive the forward voltage drop of white LEDs. The CM9156A requires only two external switched, or bucket, capacitors plus an input and an output capacitor, providing for a compact, low profile design. In many applications, all these can conveniently be the same value of 1.0µF, commonly available in a compact 0805 surface mount package.

The CM9156A is intended for white LED applications, but it can drive most all types of LEDs with a forward voltage drop of less than 4V.

The LED current is determined by its series resistor, R_{LED} , and is approximately;

$$I_{LED} = \frac{4.5V - V_{FWD_LED}}{R_{LED}}$$

Typical white LEDs have a forward voltage drop, V_{FWD_LED} , of 3.5V to 3.7V. Like single junction devices, white LEDs often have poorly matched forward voltages. If the LEDs were put in parallel without a series resistor, the current in the paralleled branches would vary, resulting in non-uniform brightness. R_{LED} , in addition to setting the current, compensates for this variation by functioning as a ballast resistor, providing negative feedback for each paralleled LED.

CM9156A Operation

When a voltage exceeding the undervoltage lockout threshold (UVLO) is applied to the VIN pin, the CM9156A initiates a softstart cycle, typically lasting 1000µs. Softstart limits the inrush current while the output capacitors are charged during the power-up of the device.

The input voltage, VIN, passes through an LDO pre-regulator that compares the output voltage to a precision bandgap reference. After the LDO, the charge pump boosts the LDO voltage by 1.5 times. A feedback circuit to the LDO monitors the output voltage, and when the output voltage reaches 4.5V, the LDO output will operate at about 3V, regulating the device output at $1.5 \times 3V = 4.5V$.

The charge pump uses two phases from the oscillator to drive internal switches that are connected to the bucket capacitors, C1 and C2, as shown in Figure 1. In the first switch position, the bucket capacitors are connected in series and each are charged from the LDO to a voltage of $V_{LDO}/2$. The next phase changes the switch positions so that C1 and C2 are put in parallel, and places them on top of V_{LDO} . The resulting voltage across C_{OUT} is then; $V_{LDO} + 1/2V_{LDO} = 1.5 \times V_{LDO}$.

When the input voltage rises above 5V, the charge pump automatically disables, removing the voltage gain stage and the output is then provided directly through the LDO, regulated at 4.5V. This increases the efficiency and minimizes chip heating in this operating condition.

The CM9156A has over-temperature and over-current protection circuitry to limit device stress and failure during short circuit conditions. An overcurrent condition will limit the output current (approximately 400mA ~ 600mA) and will cause the output voltage to drop, until automatically resetting after removal of the excessive current. Over-temperature protection disables the IC when the junction is about 135°C, and automatically turns on the IC when the junction temperature drops by approximately 15°C.

Application Information (cont'd)

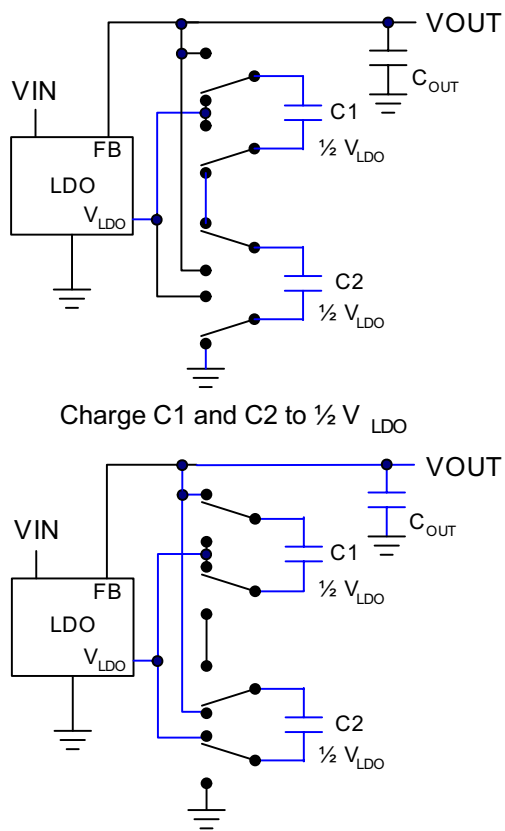

Figure 1. Switch operation

Efficiency

A conventional charge pump with a fixed gain of 2x will usually develop more voltage than is needed to drive paralleled white LEDs from Li-Ion sources. This excessive gain develops a higher internal voltage, reducing system efficiency and increasing battery drain in portable devices. A fractional charge pump with a gain of 1.5x is better suited for driving white LEDs in these applications.

The CM9156A charge pump automatically switches between two conversion gains, 1x and 1.5x, allowing high efficiency levels over a wide operating input voltage range. The 1x mode allows the regulated LDO voltage to pass directly through to the output when sufficient input voltage is available. The 1.5x charge pump is enabled only when the battery input is too low to sustain the output load.

At nominal loads, the switching losses and quiescent current are negligible. If these losses are ignored for simplicity, the efficiency, η , for an ideal 1.5x charge pump can be expressed as the output power divided by the input power;

$$\eta \approx \frac{P_{OUT}}{P_{IN}}$$

For an ideal 1.5x charge pump, $I_{IN} = 1.5 \times I_{OUT}$, and the efficiency may be expressed as;

$$\frac{P_{OUT}}{P_{IN}} \approx \left(\frac{V_{OUT} \times I_{OUT}}{V_{IN} \times 1.5 \times I_{OUT}} \right) = \frac{V_{OUT}}{1.5 \times V_{IN}}$$

$$V_{OUT} = 4.5V, \quad \therefore \eta \approx \frac{4.5V}{1.5 \times V_{IN}}$$

The ideal 2x charge pump can be similarly expressed;

$$\frac{P_{OUT}}{P_{IN}} \approx \frac{4.5V}{2.0 \times V_{IN}}$$

In 1x mode, when the input voltage is above the output voltage, the part functions as a linear regulator and the ideal efficiency is simply V_{OUT}/V_{IN} .

The typical conversion efficiency plots for these modes, with some losses, are shown in [Figure 2](#).

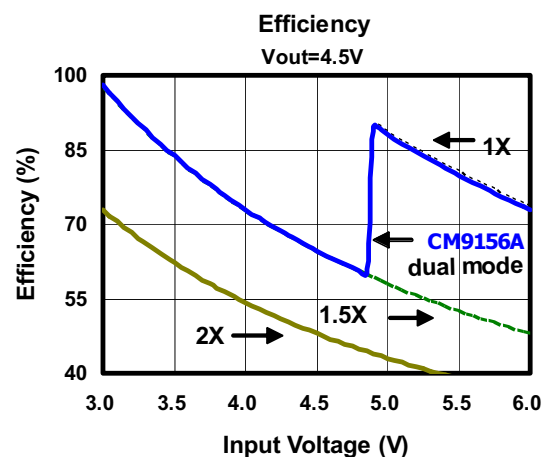

Figure 2. Ideal efficiency curve

Application Information (cont'd)

As can be seen, the CM9156A, with 1x and 1.5x modes, has better efficiency in this application than a fixed 2x charge pump. At low battery voltages, the higher efficiency of the charge pump's 1.5x gain reduces the battery drain. At higher input voltages, above 4.9V typically seen when the system is running off an AC adapter, the CM9156A, operating the 1x mode, has better efficiency than single mode 1.5x or 2x charge pumps, lowering the power dissipation for cooler circuit operation and long life.

The external bucket capacitors will affect the output impedance of the converter, so surface-mount, low ESR ceramic capacitors are recommended. Tantalum and Aluminum capacitors should not be used because their ESR is too high. The ceramic dielectric must be stable over the operating temperature and voltage range hence X7R or X5R are recommended. In noise sensitive applications, output ripple can be further reduced by increasing the capacitance of the output capacitor. Reflected input ripple current depends on the impedance of the VIN source, which includes the PCB traces. Increasing the input capacitor will reduce this ripple. The input capacitor also affects the output voltage ripple. All the capacitors should be located close to the device for best performance.

Frequency Selection

The optimal switching frequency depends on the allowable system current draw, the load current, ripple and EMI requirements. The CM9156A's operating frequency choices are; 8kHz, 32kHz, 262kHz, or 650kHz. These frequencies are selected by programming the two digital inputs; CLK1 and CLK2. Refer to Table 1. The supply current for a charge pump is proportional to its switching frequency. A lower switching frequency allows reduced quiescent current for more efficient operation, but reduces the output current capability, and in some cases, causes higher ripple. Higher frequencies are used when larger load currents are demanded.

The frequency is typically selected to achieve maximum efficiency while avoiding sensitive frequencies with the switching fundamental and its harmonics. The switching frequency can be set outside the critical frequency spectrums of cellular communications bandwidths. Once set, the switching frequency and its harmonics remain fixed, making filtering easy.

LED Brightness Control

Changes in ambient light often require the backlight display intensity to be adjusted, usually to conserve battery life. There are simple solutions to lowering the LED brightness when using the CM9156A. A typical example is shown in Figure 3.

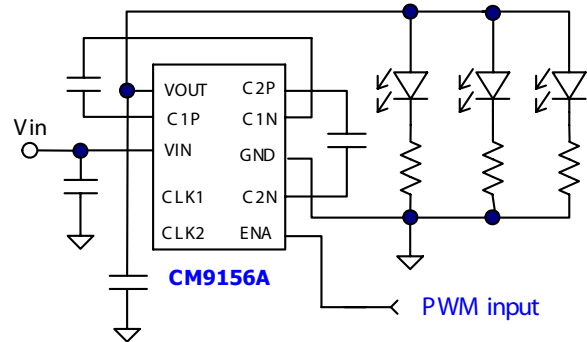

Figure 3. PWM applied to ENA

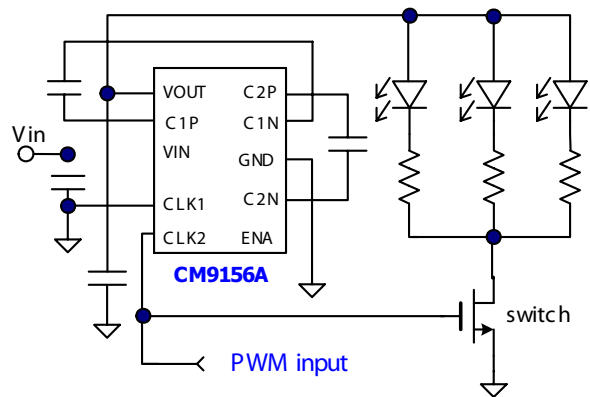

Figure 4. Brightness control, lower quiescent current

A PWM signal can be used to control the brightness, which is more efficient than other solutions that dissipate unwanted LED current in the series resistors. It also maintains LED color fidelity by avoiding color temperature changes that current variations cause to white LEDs. The LED intensity is determined by the PWM duty cycle, which can vary from 0% to 100%.

In the configuration shown in Figure 4, the brightness is controlled by the PWM signal applied to the LEDs.

Application Information (cont'd)

Decreased Duty Cycle will lower the LED brightness, See [Figure 5](#) and [Figure 6](#). The same signal is also applied to the CM9156A, reducing the charge pump switching frequency via the CLK2 control. When the PWM signal is high, CLK1 is low, CLK2 goes high, the operating frequency is 262kHz (refer to [Table 1](#)), and the LED current path is complete through the switch. When the PWM signal is low, the LED current is stopped as the switch turns off, and the switching frequency of the charge pump becomes 32kHz (CLK1, CLK2 = 0). Operating the charge pump at the lower frequency lowers the quiescent current when the charge pump is operational (the input voltage below 5V).

The recommended PWM frequency is between 100Hz and 20kHz. If a frequency of less than 100Hz is used, flicker might be seen in the LEDs. The frequency should also be greater than the refresh rate of the TFT display. Higher frequencies will cause a loss of brightness control linearity. In addition, higher frequency can cause chromaticity shifts because the fixed rise and fall times of the PWM signal will shift the forward current.

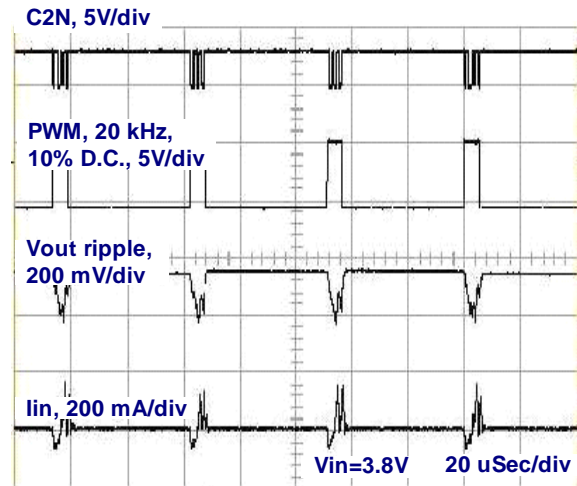

Figure 6. Low brightness waveforms

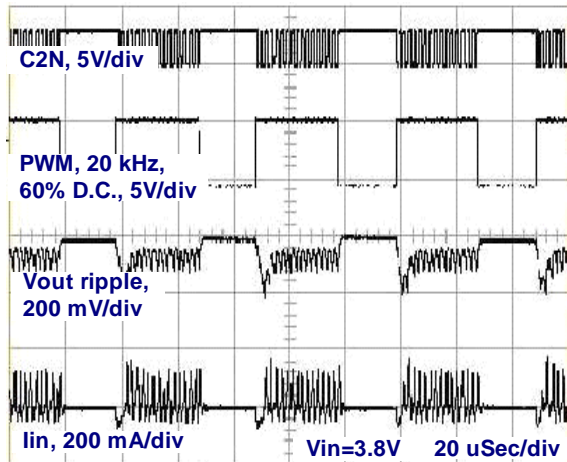

Figure 5. High brightness waveforms

Camera Flash Application

Many smart phones and PDAs include a digital camera. These cameras typically utilize a WLED flash to illuminate the picture subject in low light conditions. The CM9156A is easily adapted to such an application. [Figure 7](#) is a typical application using the CM9156A as a WLED flash driver, which is ideal for this application because it is capable of driving up to 120mA from a Li-ion battery. The One-shot is used to create a single pulse of a set duration to the ENA pin of the CM9156A.

The Flash LED modules shown here contain three matched WLEDs with a common anode and separated cathodes. The series resistor is chosen based on the forward drop of the module LEDs (typically 3.3V to 3.8V) and the number of parallel LEDs being driven.

Application Information (cont'd)

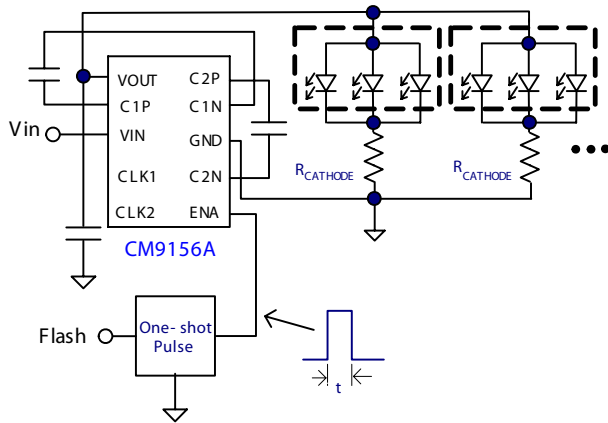
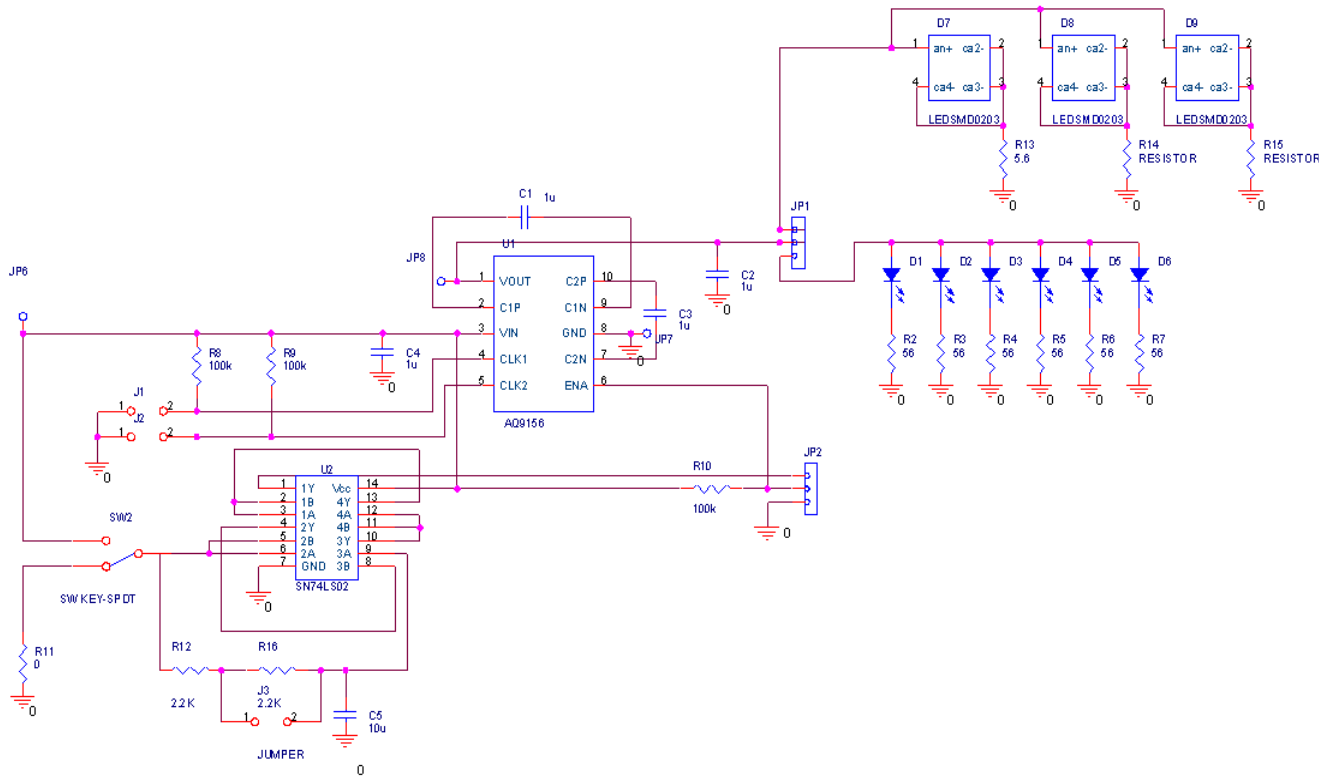

Figure 7. Camera flash application

Layout Guide

The charge pump is rapidly charging and discharging its external capacitors, so external traces to the capacitors should be made as wide and short as allowable to minimize inductance and high frequency ringing. The four capacitors should be located as close as practical to the charge pump, particularly C1 and C2, which have the highest dv/dt. Connect ground and power traces to the capacitors through short, low impedance paths. Use a solid ground plane, ideally on the backside of the PCB, which should carry only ground potential. Connect the ground side of C_{IN}, C_{out} and the chip GND as close as practical. For best thermal performance, the exposed backside lead frame should be soldered to the PCB.

Application Evaluation Circuit



- Note 1: Pull-up and current setting resistor values will vary with application.
- Note 2: JP1 jumper selects either Flash WLED application or WLED for LCD backlight application.
- Note 3: JP2 jumper selects Flash signal or disables signal connected to ENA pin. If JP2 is not jumpered, then ENA is pulled high.
- Note 4: Flash WLEDs have three cathodes and one common anode.
- Note 5: The SN74LS02 is configured as a one-shot pulse generator, with time controlled by R12, R16, and C5.
- Note 6: J3 jumper inserted will create a 1/60 s flash pulse (16 ms). Without J3 jumper inserted the flash pulse will be 1/30 s (33 ms).

Mechanical Details

TDFN-10 Mechanical Specifications

Dimensions for the CM9156A packaged in a 10-lead TDFN package are presented below.

For complete information on the TDFN-10, see the California Micro Devices TDFN Package Information document.

PACKAGE DIMENSIONS						
Package	TDFN					
JEDEC No.	MO-229 (Var. WEED-3) ¹					
Leads	10					
Dim.	Millimeters			Inches		
	Min	Nom	Max	Min	Nom	Max
A	0.70	0.75	0.80	0.028	0.030	0.031
A1	0.00	0.02	0.05	0.000	0.001	0.002
A2	0.45	0.55	0.65	0.018	0.022	0.026
A3		0.20			0.008	
b	0.18	0.25	0.30	0.007	0.010	0.012
D		3.00			0.118	
D2	2.20	2.30	2.40	0.087	0.091	0.094
E		3.00			0.118	
E2	1.40	1.50	1.60	0.055	0.060	0.063
e		0.50			0.020	
K	1.30	1.50	1.70	0.051	0.060	0.067
L	0.20	0.30	0.40	0.008	0.012	0.016
# per tube	NA					
# per tape and reel	3000 pieces					
Controlling dimension: millimeters						

¹This package is compliant with JEDEC standard MO-229, variation WEED-3 with exception of the "D2" and "E2" dimensions as called out in the table above.

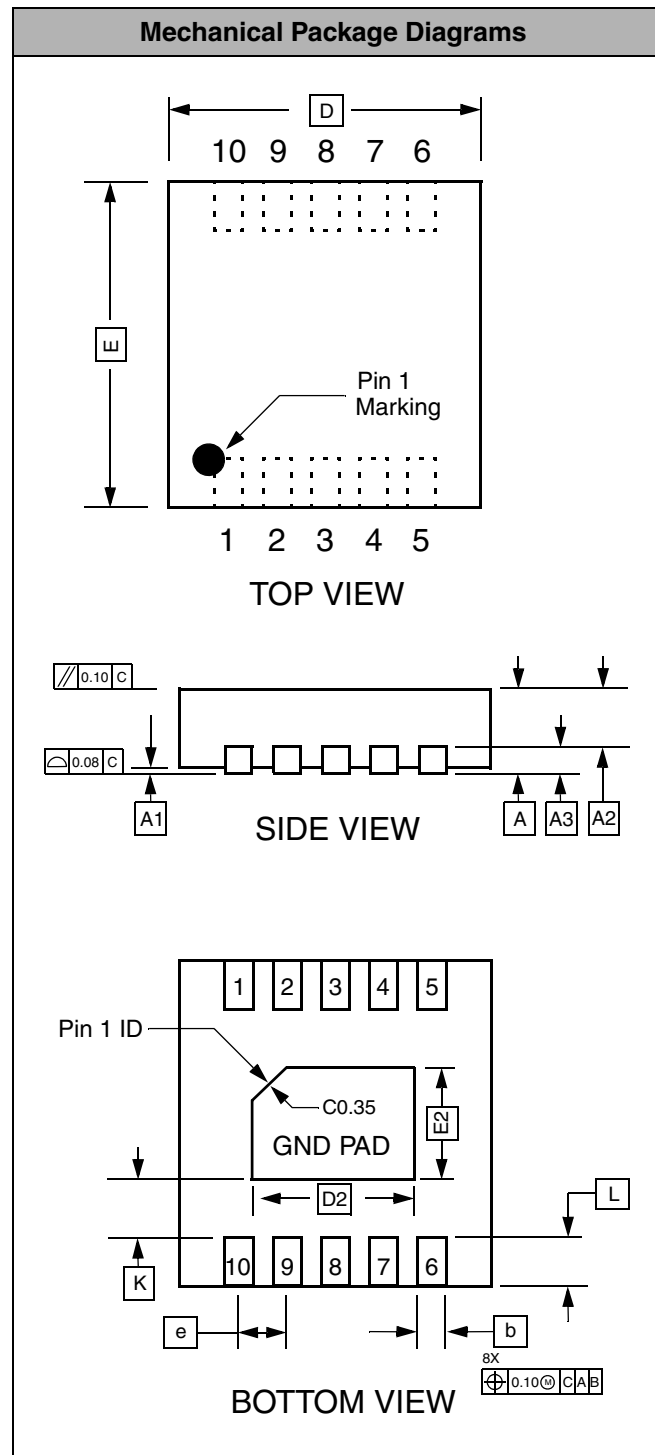

Package Dimensions for 10-Lead TDFN

Mechanical Details (cont'd)

MSOP-10 Mechanical Specifications:

The CM9156A is supplied in a 10-pin MSOP. Dimensions are presented below.

For complete information on the MSOP-10, see the California Micro Devices MSOP Package Information document.

PACKAGE DIMENSIONS				
Package	MSOP			
Pins	10			
Dimensions	Millimeters		Inches	
	Min	Max	Min	Max
A	0.75	0.95	0.030	0.038
A1	0.05	0.15	0.002	0.006
B	0.17	0.33	0.007	0.013
C	0.15	0.30	0.006	0.018
D	2.90	3.10	0.114	0.122
E	2.90	3.10	0.114	0.122
e	0.50 BSC		0.0197 BSC	
H	4.90 BSC		0.193 BSC	
L	0.40	0.70	0.0157	0.0276
# per tape and reel	4000			
Controlling dimension: inches				

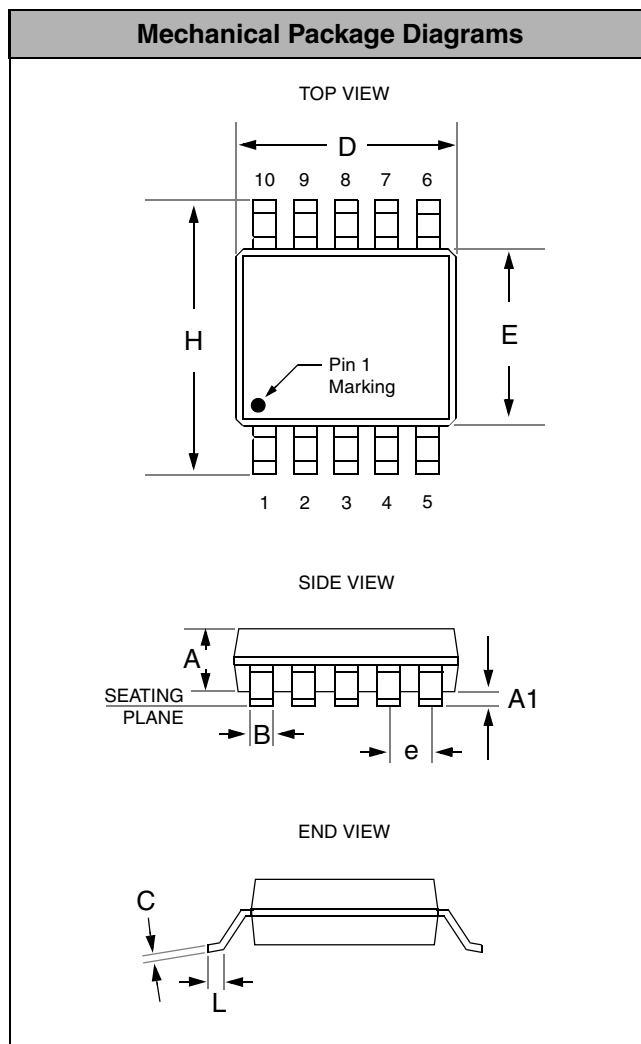

Package Dimensions for MSOP-10