

**PULSE-WIDTH-MODULATION CONTROL CIRCUITS****AZ494****General Description**

The AZ494 incorporates on a single chip all the functions required in the construction of a pulse-width-modulation (PWM) control circuit. Designed primarily for power supply control, this device offers the flexibility to tailor the power supply control circuitry to a specific application.

The AZ494 contains two error amplifiers, an on-chip adjustable oscillator, a dead-time control (DTC) comparator, a pulse-steering control flip-flop, a 5V regulator, and output control circuits. The error amplifiers exhibit a common-mode voltage range from $-0.3V$ to $V_{CC}-2V$. The dead-time control comparator has a fixed offset that provides approximately 5% dead time. The on-chip oscillator can be bypassed by terminating the RT pin to the reference output and providing a saw-tooth input to the CT pin, or it can drive the common circuits in synchronous multiple-rail power supplies.

The uncommitted output transistors can be configured in either common-emitter or emitter-follower output topology. The AZ494 provides for push-pull or single-ended output operation, which can be selected through the output control function. The architecture of this device prohibits the possibility of either output being pulsed twice during push-pull operation. The AZ494 is characterized for operation from $-40^{\circ}C$ to $85^{\circ}C$.

Features

- Complete PWM power-control circuitry
- Uncommitted outputs for 200mA sink or source current
- Output control selects single-ended or push-pull operation
- Internal circuitry prohibits double pulse at either output
- Variable dead time provides control over total range
- Internal regulator provides a stable 5V reference supply with 5% tolerance
- Circuit architecture allows easy synchronization

Applications

- SMPS
- Back Light Inverter

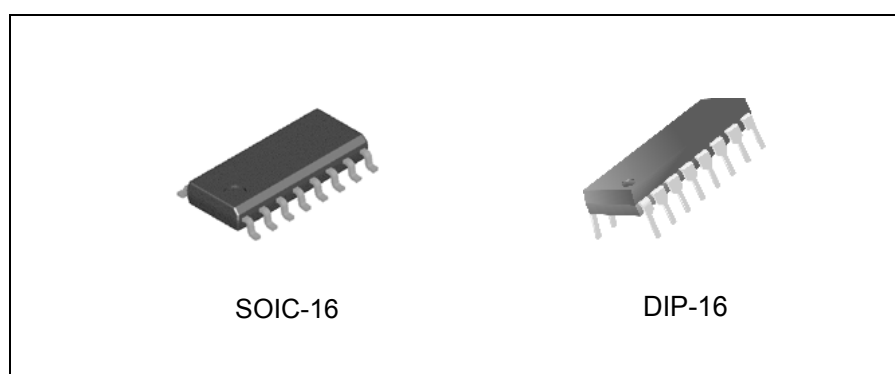

Figure 1. Package Types of AZ494



PULSE-WIDTH-MODULATION CONTROL CIRCUITS

AZ494

Pin Configuration

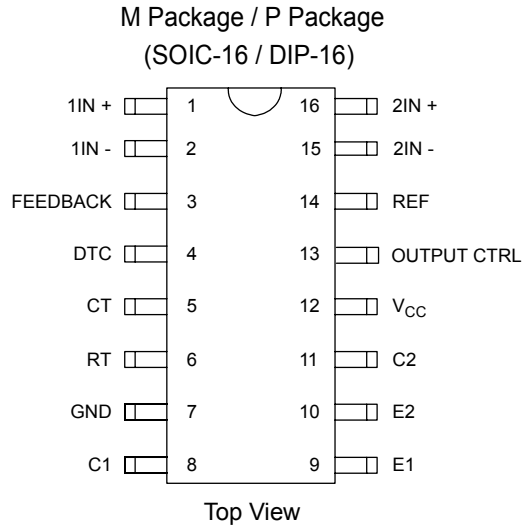

Figure 2. Pin Configuration of AZ494

Function Table

Input To Output Control	Output Function
$V_I = \text{GND}$	Single-ended or parallel output
$V_I = V_{\text{ref}}$	Normal push-pull operation

Functional Block Diagram

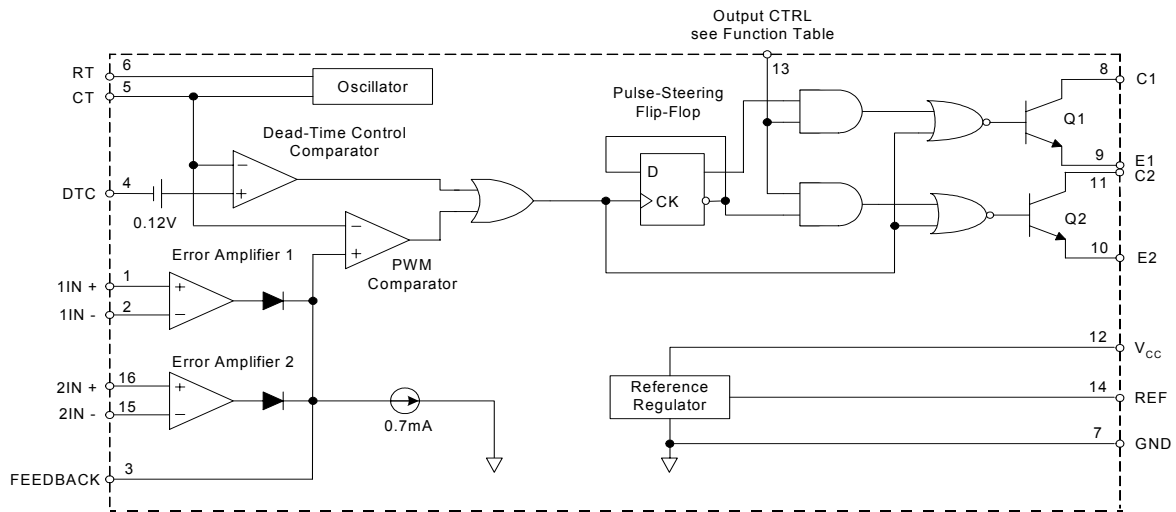

Figure 3. Functional Block Diagram of AZ494

**PULSE-WIDTH-MODULATION CONTROL CIRCUITS****AZ494****Ordering Information**

Package	Temperature Range	Part Number	Marking ID	Packing Type
SOIC-16	-40°C~85°C	AZ494M	AZ494M	Tube
DIP-16		AZ494P	AZ494P	Tube

Absolute Maximum Ratings (Note 1)

Parameter	Symbol	Value	Unit	
Supply Voltage (Note 2)	V_{CC}	40	V	
Amplifier Input Voltage	V_I	-0.3 to $V_{CC} + 0.3$	V	
Collector Output Voltage	V_O	40	V	
Collector Output Current	I_O	250	mA	
Package Thermal Impedance (Note 3)	θ_{JA}	M Package	73	°C/W
		P Package	67	
Lead Temperature 1.6mm from case for 10 seconds		260	°C	
Storage Temperature Range	T_{STG}	-65 to 150	°C	
ESD rating (Machine Model)		200	V	

Note 1: Stresses greater than those listed under "Absolute Maximum Ratings" may cause permanent damage to the device. These are stress ratings only, and functional operation of the device at these or any other conditions beyond those indicated under "Recommended Operation Ratings" is not implied. Exposure to "Absolute Maximum Ratings" for extended periods may affect device reliability.

Note 2: All voltage values are with respect to the network ground terminal.

Note 3: Maximum power dissipation is a function of $T_J(\max)$, θ_{JA} and T_A . The maximum allowable power dissipation at any allowable ambient temperature is $P_D = (T_J(\max) - T_A) / \theta_{JA}$. Operating at the absolute maximum T_J of 150°C can affect reliability.

**PULSE-WIDTH-MODULATION CONTROL CIRCUITS****AZ494****Recommended Operating Conditions**

Parameter	Symbol	Min	Max	Unit
Supply Voltage	V_{CC}	7	36	V
Amplifier Input Voltage	V_I	-0.3	$V_{CC} - 2$	V
Collector Output Voltage	V_O		36	V
Collector Output Current (Each Transistor)			200	mA
Current Into Feedback Terminal			0.3	mA
Oscillator Frequency	f_{osc}		300	KHz
Timing Capacitor	C_T	0.47	10000	nF
Timing Resistor	R_T	1.8	500	K Ω
Operating Free-Air Temperature	T_A	-40	85	$^{\circ}\text{C}$



PULSE-WIDTH-MODULATION CONTROL CIRCUITS **AZ494**

Electrical Characteristics

All typical values, except for parameter changes with temperature, are at $T_A = 25^\circ\text{C}$.

$V_{CC}=15\text{V}$, $f=10\text{KHz}$ unless otherwise noted.

Parameter	Symbol	Conditions (Note 4)	Min	Typ	Max	Unit
Reference Section						
Output Voltage (REF)	V_{ref}	$I_O=1\text{mA}$	4.75	5	5.25	V
Line Regulation		$V_{CC} = 7\text{V to } 36\text{V}$		2	25	mV
Load Regulation		$I_O=1\text{mA to } 10\text{mA}$		1	15	mV
Output Voltage Change with Temperature		$\Delta T_A = \text{MIN to MAX}$		2	10	mV/V
Short-Circuit Output Current (Note 5)	I_{SC}	REF = 0V		25		mA
Oscillator Section, $C_T = 0.01\mu\text{F}$, $R_T = 12\text{K}\Omega$ (See Figure 4)						
Frequency	f_{osc}			10		KHz
Standard Deviation of Frequency (Note 6)		All values of V_{CC} , C_T , R_T and T_A constant		100		Hz/KHz
Frequency Change with Voltage		$V_{CC}=7\text{V to } 36\text{V}$, $T_A = 25^\circ\text{C}$		1		Hz/KHz
Frequency Change with Temperature (Note 7)		$\Delta T_A = \text{MIN to MAX}$			10	Hz/KHz
Error-Amplifier Section (See Figure 5)						
Input Offset Voltage	V_{OS}	$V_O (\text{FEEDBACK}) = 2.5\text{V}$		2	10	mV
Input Offset Current	I_{OS}	$V_O (\text{FEEDBACK}) = 2.5\text{V}$		25	250	nA
Input Bias Current	I_{BIAS}	$V_O (\text{FEEDBACK}) = 2.5\text{V}$		0.2	1	μA
Common-Mode Input Voltage Range		$V_{CC}=7\text{V to } 36\text{V}$	-0.3 to $V_{CC}-2$			V
Large-Signal Open-Loop Voltage Gain	A_{VO}	$\Delta V_O = 3\text{V}$, $R_L = 2\text{K}\Omega$, $V_O = 0.5\text{V to } 3.5\text{V}$	70	95		dB
Large-Signal Unity-Gain Bandwidth	GB	$V_O = 0.5\text{V to } 3.5\text{V}$, $R_L = 2\text{K}\Omega$		800		KHz
Common-Mode Rejection Ratio	CMRR	$\Delta V_O = 36\text{V}$, $T_A = 25^\circ\text{C}$	65	80		dB
Output Sink Current (FEEDBACK)	I_{SINK}	$V_{ID} = -15\text{mV to } -5\text{V}$, $V(\text{FEEDBACK}) = 0.7\text{V}$	0.3	0.7		mA
Output Source Current (FEEDBACK)	I_{SOURCE}	$V_{ID} = 15\text{mV to } 5\text{V}$, $V(\text{FEEDBACK}) = 3.5\text{V}$	-2			mA
Output Section						
Collector Off-State Current	$I_{C, OFF}$	$V_{CE} = 36\text{V}$, $V_{CC}=36\text{V}$		2	100	μA
Emitter Off-State Current	$I_{E, OFF}$	$V_{CC} = V_C = 36\text{V}$, $V_E = 0$			-100	μA
Collector-Emitter Saturation Voltage	Common Emitter	$V_E = 0$, $I_C = 200\text{mA}$		1.1	1.3	V
	Emitter Follower	$V_O (C1 \text{ or } C2) = 15\text{V}$, $I_E = -200\text{mA}$		1.5	2.5	



PULSE-WIDTH-MODULATION CONTROL CIRCUITS **AZ494**

Electrical Characteristics (Continued)

Parameter	Symbol	Conditions	Min	Typ	Max	Unit	
Output Control Input Current		$V_I = V_{ref}$			3.5	mA	
Dead-Time Control Section							
Input Bias Current		$V_I = 0$ to 5.25V		-2	-10	μ A	
Maximum Duty Cycle, Each Output		V_I (DEAD-TIME CTRL) = 0, $C_T = 0.01\mu$ F, $R_T = 12K\Omega$		45		%	
Input Threshold Voltage		Zero Duty Cycle		3	3.3	V	
		Maximum Duty Cycle	0				
PWM Comparator Section (See Figure 4)							
Input Threshold Voltage (FEEDBACK)		Zero duty cycle		4	4.5	V	
Input Sink Current (FEEDBACK)		$V(\text{FEEDBACK}) = 0.7V$	0.3	0.7		mA	
Total Device							
Standby Supply Current	I_{STDBY}	$R_T = V_{ref}$, All other inputs and outputs open	$V_{CC} = 15V$		6	10	mA
			$V_{CC} = 36V$		9	15	
Average Supply Current		V_I (DEAD-TIME-CTRL) = 2V See Figure 4.		7.5		mA	
Switching Characteristics							
Rise Time	t_r	Common-emitter Configuration See Figure 6		100	200	ns	
Fall Time	t_f			25	100	ns	
Rise Time	t_r	Emitter-follower Configuration See Figure 7		100	200	ns	
Fall Time	t_f			40	100	ns	

Note 4: For conditions shown as MIN or MAX, use the appropriate value specified under recommended operating conditions.

Note 5: Duration of the short circuit should not exceed one second.

Note 6: Standard deviation is a measure of the statistical distribution about the mean as derived from the formula:

$$\sigma = \sqrt{\frac{\sum_{n=1}^N (X_n - \bar{X})^2}{N - 1}}$$

Note 7: Temperature coefficient of timing capacitor and timing resistor are not taken into account.



PULSE-WIDTH-MODULATION CONTROL CIRCUITS

AZ494

Parameter Measurement Information

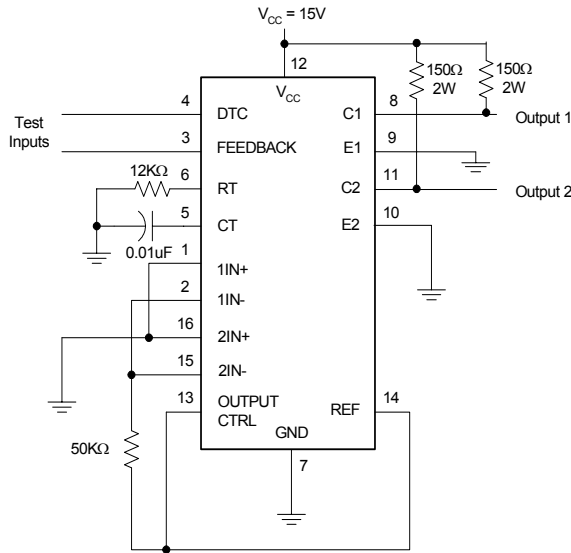

Test Circuit

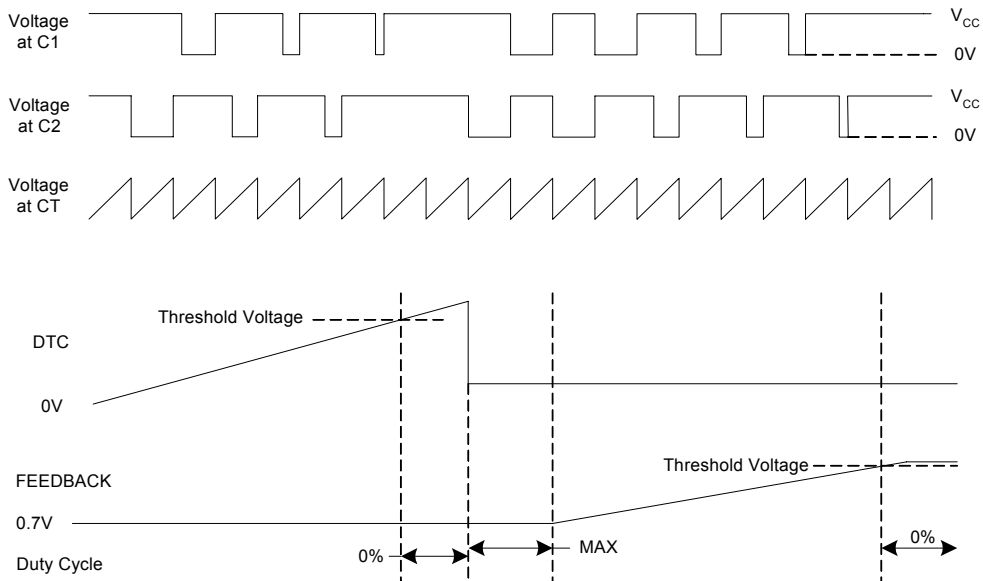

Voltage Waveforms

Figure 4. Operational Test Circuit and Waveforms



PULSE-WIDTH-MODULATION CONTROL CIRCUITS

AZ494

Parameter Measurement Information

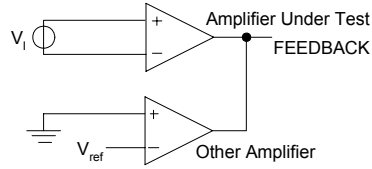
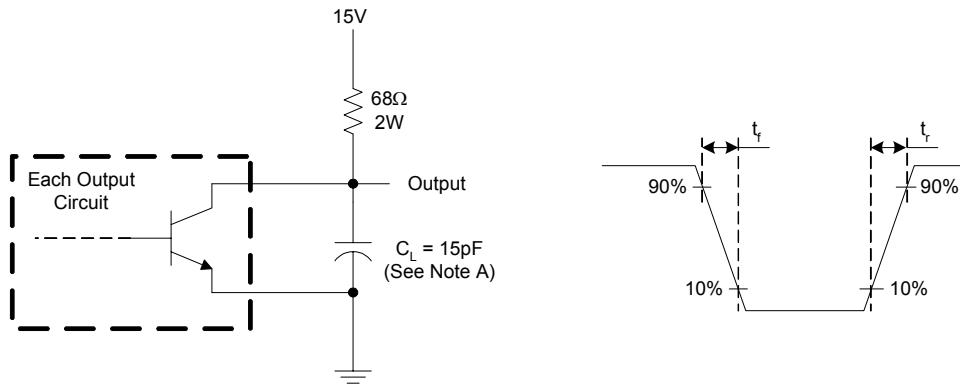
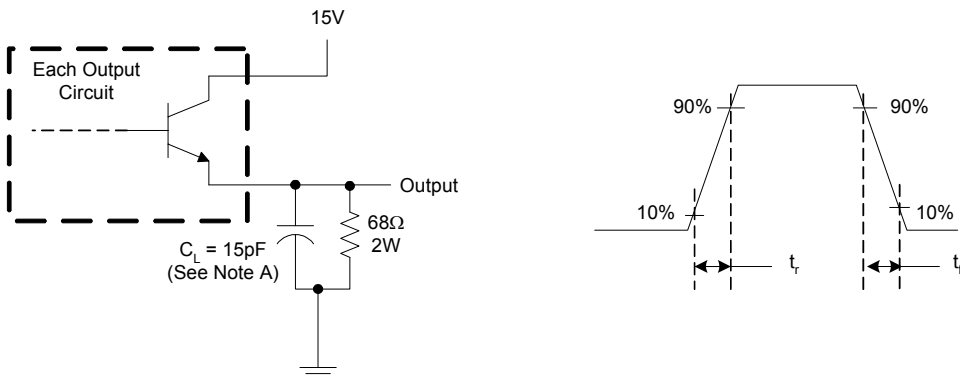

Figure 5. Error Amplifier Characteristics



Note A: C_L includes probe and jig capacitance.

Figure 6. Common-Emitter Configuration



Note A: C_L includes probe and jig capacitance.

Figure 7. Emitter-Follower Configuration



Typical Characteristics

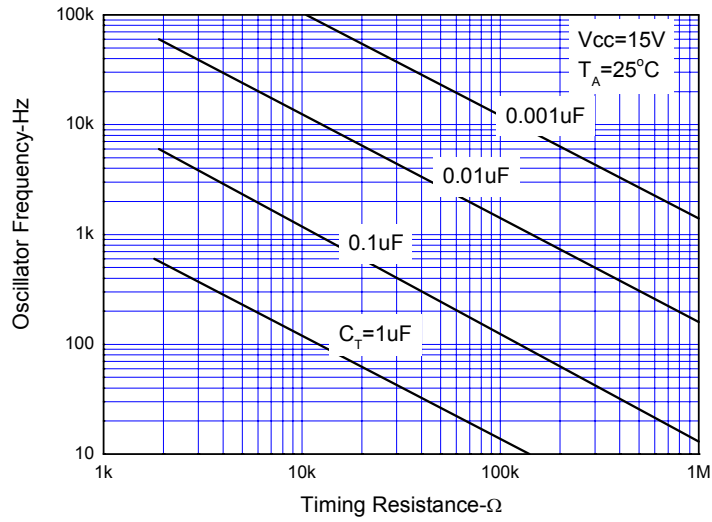

Figure 8. Oscillator Frequency vs. Timing Resistance

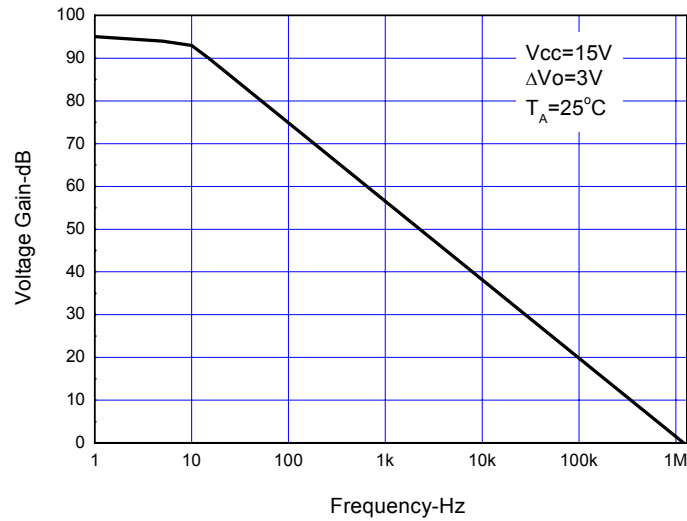
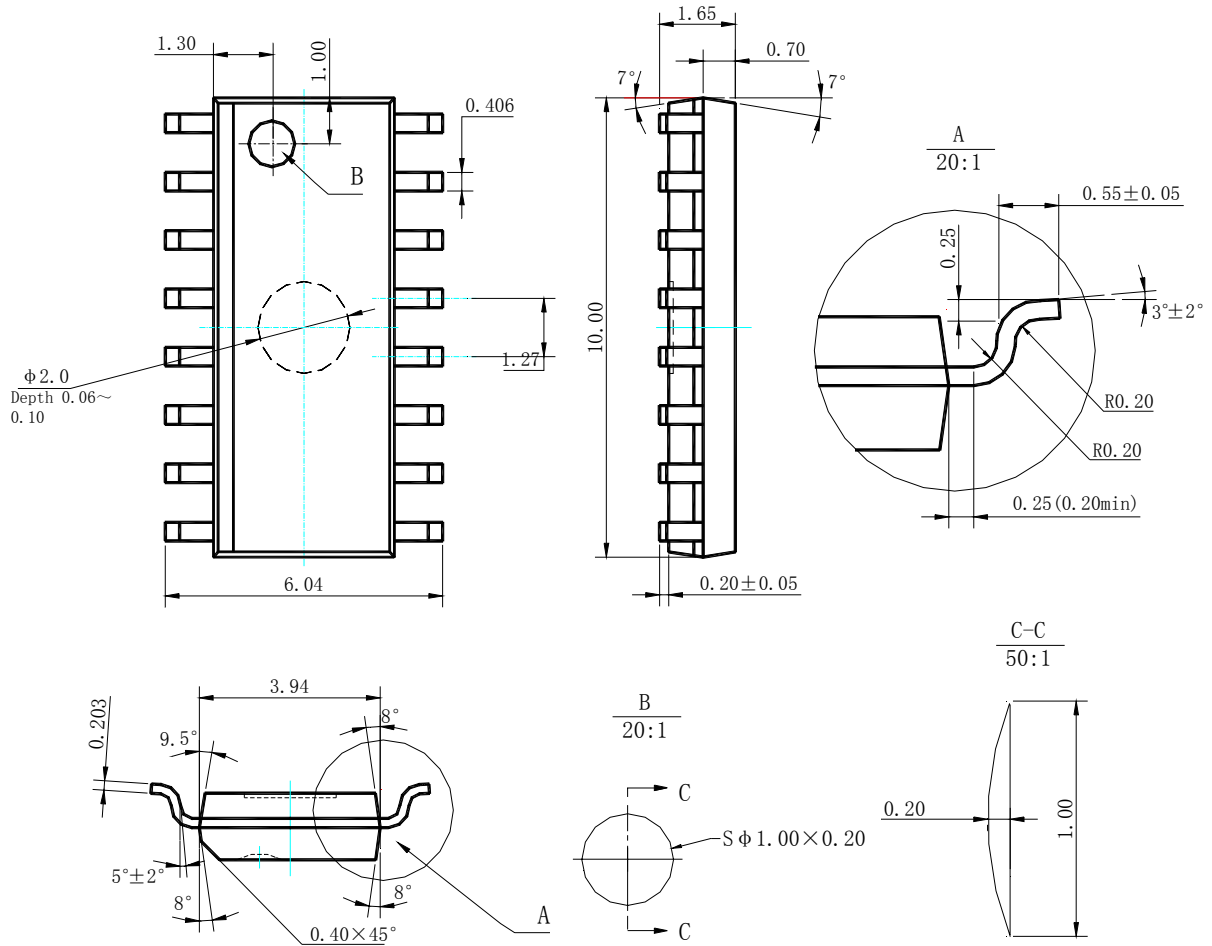

Figure 9. Error Amplifier Small-Signal Voltage Gain vs. Frequency



Mechanical Dimensions

SOIC-16





Mechanical Dimensions (Continued)

DIP-16

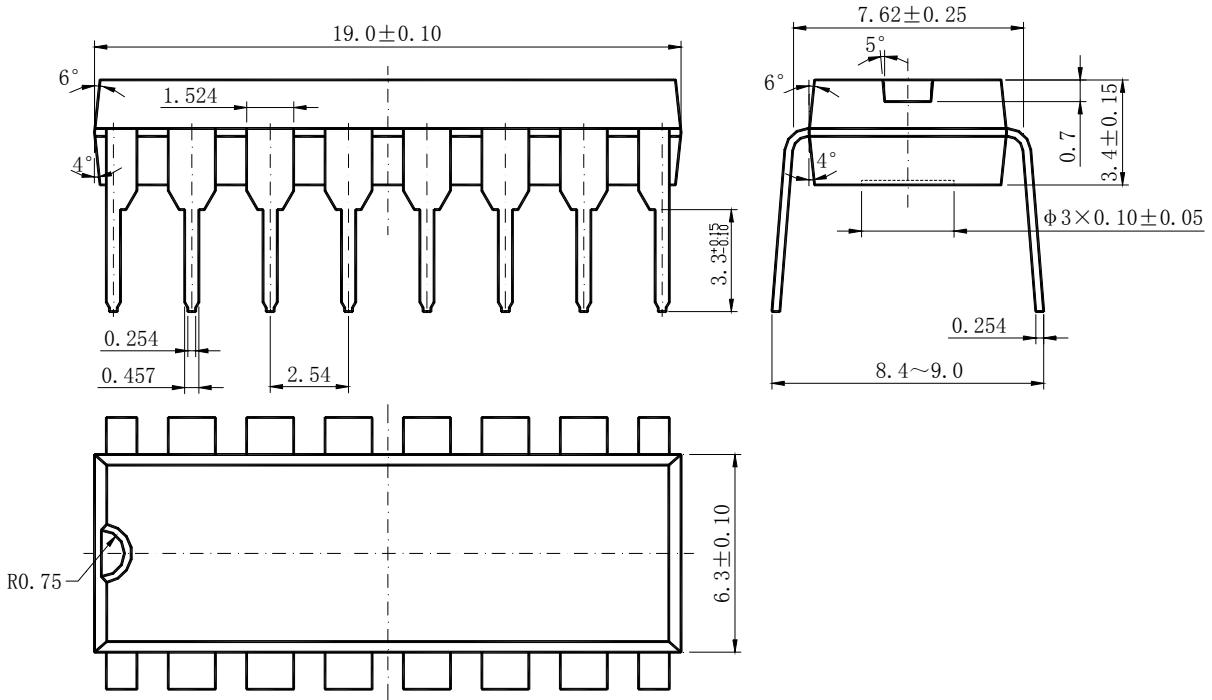



<http://www.aacmicro.com>

USA: 1510 Montague Expressway, San Jose, CA 95131, USA

Tel: 408-433 9888, Fax: 408-432 9888

China: 8th Floor, Zone B, 900 Yi Shan Road, Shanghai 200233, China

Tel: 86-21-6495 9539, Fax: 86-21-6485 9673

Taiwan: Room 2210, 22nd Fl, 333, Keelung Road, Secretary 1, Taipei, Taiwan

Tel: 886-2-2564 3699, Fax: 886-2-2564 3770

IMPORTANT NOTICE

Advanced Analog Circuits Corporation reserves the right to make changes to its products or specifications at any time, without notice, to improve design or performance and to supply the best possible product. Advanced Analog Circuits does not assume any responsibility for use of any circuitry described other than the circuitry embodied in Advanced Analog Circuits' products. The company makes no representation that circuitry described herein is free from patent infringement or other rights of Advanced Analog Circuits Corporation.