



rev 1.6

## Low Power Peak EMI Reducing Solution

### Features

- Generates an EMI optimized clock signal at the output.
- Integrated loop filter components.
- Operates with a 3.3V /2.5V supply.
- Operating current less than 4mA.
- Low power CMOS design.
- Input frequency range : 6MHz to 12MHz for 2.5V  
: 6MHz to 13MHz for 3.3V
- Generates a 1X low EMI spread spectrum clock of the input frequency.
- Frequency deviation:  $\pm 1\%$  @ 10MHz
- Available in 6-pin TSOT-23, 8-pin SOIC and 8-pin TSSOP packages.

### Product Description

The ASM3P2669A is a versatile spread spectrum frequency modulator designed specifically for a wide range of clock frequencies. The ASM3P2669A reduces electromagnetic interference (EMI) at the clock source, allowing system wide reduction of EMI of all clock dependent signals. The ASM3P2669A allows significant system cost savings by reducing the number of circuit board layers ferrite beads, shielding that are traditionally required to pass EMI regulations.

The ASM3P2669A uses the most efficient and optimized modulation profile approved by the FCC and is implemented by using a proprietary all digital method.

The ASM3P2669A modulates the output of a single PLL in order to “spread” the bandwidth of a synthesized clock, and more importantly, decreases the peak amplitudes of its harmonics. This results in significantly lower system EMI compared to the typical narrow band signal produced by oscillators and most frequency generators. Lowering EMI by increasing a signal’s bandwidth is called ‘spread spectrum clock generation’.

### Applications

The ASM3P2669A is targeted towards all portable devices with very low power requirements like MP3 players and digital still cameras.

### Key Specifications

Description	Specification
Supply voltages	VDD = 3.3V /2.5V
Cycle-to-Cycle Jitter	200pS ( Max)
Output Duty Cycle	45/55%
Modulation Rate Equation	$F_{IN}/256$
Frequency Deviation	$\pm 1\%$ @ 10MHz

### Block Diagram

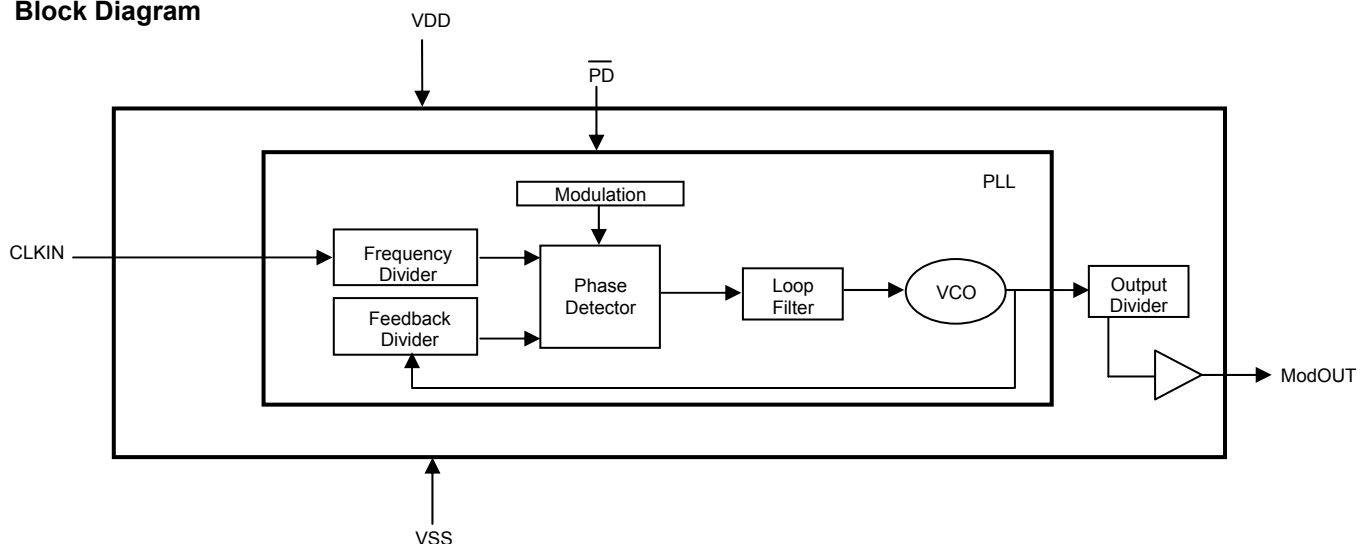



rev 1.6

## Pin Configuration (6-pin TSOT-23 Package)

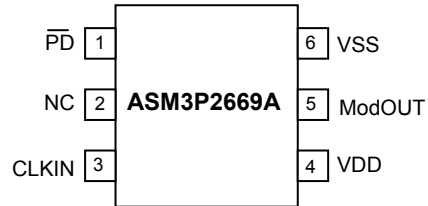

## Pin Description

Pin#	Pin Name	Type	Description
1	$\overline{\text{PD}}$	I	Power-down control pin. Pull low to enable power-down mode. Connect to VDD if not used.
2	NC	-	No connect.
3	CLKIN	I	External reference frequency input.
4	VDD	P	Power supply for the entire chip
5	ModOUT	O	Spread spectrum clock output.
6	VSS	P	Ground connection.



rev 1.6

## Pin Configuration (8-pin SOIC and TSSOP Package)

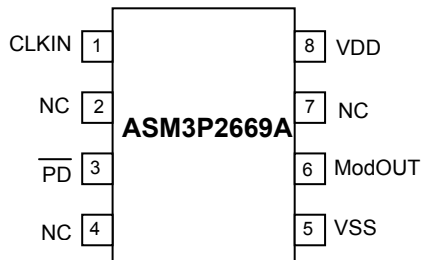

## Pin Description

Pin#	Pin Name	Type	Description
1	CLKIN	I	External reference frequency input.
2	NC	-	No Connect.
3	$\overline{\text{PD}}$	I	Power-down control pin. Pull low to enable power-down mode. Connect to VDD if not used.
4	NC	-	No connect.
5	VSS	P	Ground connection.
6	ModOUT	O	Spread spectrum clock output.
7	NC	-	No connect.
8	VDD	P	Power supply for the entire chip

## Modulation Profile

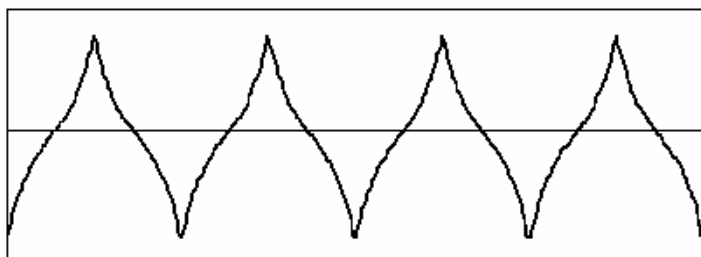

## Specifications

Description		Specification
Frequency Range	For 2.5V Supply	6MHz < CLKIN < 12MHz
	For 3.3V Supply	6MHz < CLKIN < 13MHz
Modulation Equation		$F_{IN}/256$
Frequency Deviation		$\pm 1\%$ @ 10MHz



rev 1.6

**Absolute Maximum Ratings**

Symbol	Parameter	Rating	Unit
VDD, V <sub>IN</sub>	Voltage on any pin with respect to Ground	-0.5 to +7.0	V
T <sub>STG</sub>	Storage temperature	-65 to +125	°C
T <sub>A</sub>	Operating temperature	0 to 70	°C
T <sub>S</sub>	Max. Soldering Temperature (10 sec)	260	°C
T <sub>J</sub>	Junction Temperature	150	°C
T <sub>DV</sub>	Static Discharge Voltage (As per JEDEC STD22- A114-B)	2	KV

Note: These are stress ratings only and are not implied for functional use. Exposure to absolute maximum ratings for prolonged periods of time may affect device reliability.

**DC Electrical Characteristics for 2.5V Supply**

(Test condition: All parameters are measured at room temperature (+25°C) unless otherwise stated)

Symbol	Parameter	Min	Typ	Max	Unit
V <sub>IL</sub>	Input low voltage	VSS - 0.3	-	0.8	V
V <sub>IH</sub>	Input high voltage	2.0	-	VDD + 0.3	V
I <sub>IL</sub>	Input low current	-	-	-35	μA
I <sub>IH</sub>	Input high current	-	-	35	μA
I <sub>XOL</sub>	XOUT output low current (@0.5V, VDD=2.5V)	-	3	-	mA
I <sub>XOH</sub>	XOUT output high current (@1.8V, VDD=2.5V)	-	3	-	mA
V <sub>OL</sub>	Output low voltage (VDD = 2.5 V, I <sub>OL</sub> = 8 mA)	-	-	0.6	V
V <sub>OH</sub>	Output high voltage (VDD = 2.5 V, I <sub>OH</sub> = 8 mA)	1.8	-	-	V
I <sub>DD</sub>	Static supply current*	-	-	10	uA
I <sub>CC</sub>	Dynamic supply current (2.5V, 10MHz and no load)	-	2.0	-	mA
VDD	Operating voltage	2.375	2.5	2.625	V
t <sub>ON</sub>	Power-up time (first locked cycle after power-up)**	-	-	5	mS
Z <sub>OUT</sub>	Output impedance	-	50	-	Ω

\* XIN/CLKIN pin and  $\overline{\text{PD}}$  pin are pulled low  
 \*\* V<sub>DD</sub> and XIN/CLKIN input are stable, PD pin is made high from low.

**AC Electrical Characteristics for 2.5V Supply**

Symbol	Parameter	Min	Typ	Max	Unit	
CLKIN	Input frequency	6	-	12	MHz	
ModOUT	Output frequency	6	-	12	MHz	
f <sub>d</sub>	Frequency Deviation	Input Frequency = 6MHz	-	±1.5	-	%
		Input Frequency = 12MHz	-	±0.8	-	
t <sub>LH</sub> *	Output rise time (measured from 0.7V to 1.7V)	0.8	1.5	1.7	nS	
t <sub>HL</sub> *	Output fall time (measured from 1.7V to 0.7V)	0.5	1.0	1.2	nS	
t <sub>JC</sub>	Jitter (cycle to cycle)	-	-	200	pS	
t <sub>D</sub>	Output duty cycle	45	50	55	%	

\* t<sub>LH</sub> and t<sub>HL</sub> are measured into a capacitive load of 15pF



## rev 1.6

## DC Electrical Characteristics for 3.3V Supply

(Test condition: All parameters are measured at room temperature (+25°C) unless otherwise stated)

Symbol	Parameter	Min	Typ	Max	Unit
V <sub>IL</sub>	Input low voltage	VSS - 0.3	-	0.8	V
V <sub>IH</sub>	Input high voltage	2.0	-	VDD + 0.3	V
I <sub>IL</sub>	Input low current	-	-	-35	μA
I <sub>IH</sub>	Input high current	-	-	35	μA
I <sub>XOL</sub>	XOUT output low current (@0.4V, VDD=3.3V)	-	3	-	mA
I <sub>XOH</sub>	XOUT output high current (@2.5V, VDD=3.3V)	-	3	-	mA
V <sub>OL</sub>	Output low voltage (VDD = 3.3 V, I <sub>OL</sub> = 8 mA)	-	-	0.4	V
V <sub>OH</sub>	Output high voltage (VDD = 3.3 V, I <sub>OH</sub> = 8 mA)	2.5	-	-	V
I <sub>DD</sub>	Static supply current*	-	-	10	uA
I <sub>CC</sub>	Dynamic supply current (3.3V, 10MHz and no load)	-	2.5	-	mA
VDD	Operating voltage	2.7	3.3	3.6	V
t <sub>ON</sub>	Power-up time (first locked cycle after power-up)**	-	-	5	mS
Z <sub>OUT</sub>	Output impedance	-	45	-	Ω

\* XIN/CLKIN pin and PD pin are pulled low  
 \*\* V<sub>DD</sub> and XIN/CLKIN input are stable, PD pin is made high from low.

## AC Electrical Characteristics for 3.3V Supply

Symbol	Parameter	Min	Typ	Max	Unit	
CLKIN	Input frequency	6	-	13	MHz	
ModOUT	Output frequency	6	-	13	MHz	
f <sub>d</sub>	Frequency Deviation	Input Frequency = 6MHz	-	±1.5	-	%
		Input Frequency = 13MHz	-	±0.75	-	
t <sub>LH</sub> *	Output rise time (measured from 0.8 to 2.0V)	0.5	1.3	1.5	nS	
t <sub>HL</sub> *	Output fall time (measured at 2.0V to 0.8V)	0.4	0.9	1.1	nS	
t <sub>JC</sub>	Jitter (cycle to cycle)	-	-	200	pS	
t <sub>D</sub>	Output duty cycle	45	50	55	%	

\*t<sub>LH</sub> and t<sub>HL</sub> are measured into a capacitive load of 15pF



rev 1.6

## Package Information

## 6-pin TSOT-23 Package

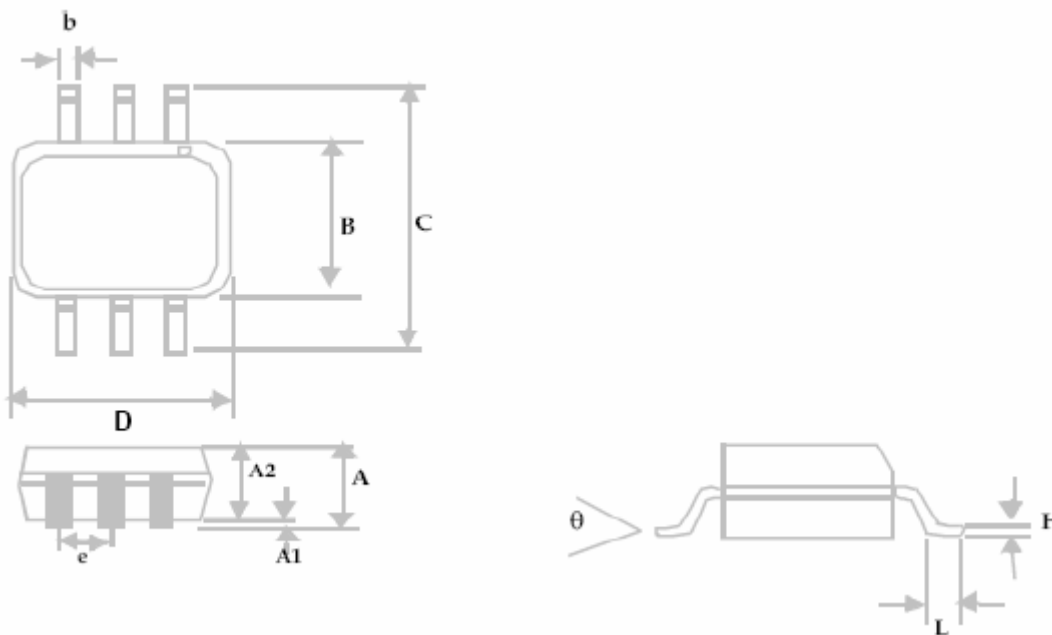

Symbol	Dimensions			
	Inches		Millimeters	
	Min	Max	Min	Max
A		0.04		1.00
A1	0.00	0.004	0.00	0.10
A2	0.033	0.036	0.84	0.90
b	0.012	0.02	0.30	0.50
H	0.005 BSC		0.127 BSC	
D	0.114 BSC		2.90 BSC	
B	0.06 BSC		1.60 BSC	
e	0.0374 BSC		0.950 BSC	
C	0.11 BSC		2.80 BSC	
L	0.0118	0.02	0.30	0.50
θ	0°	4°	0°	4°



rev 1.6

8-Pin SOIC Package

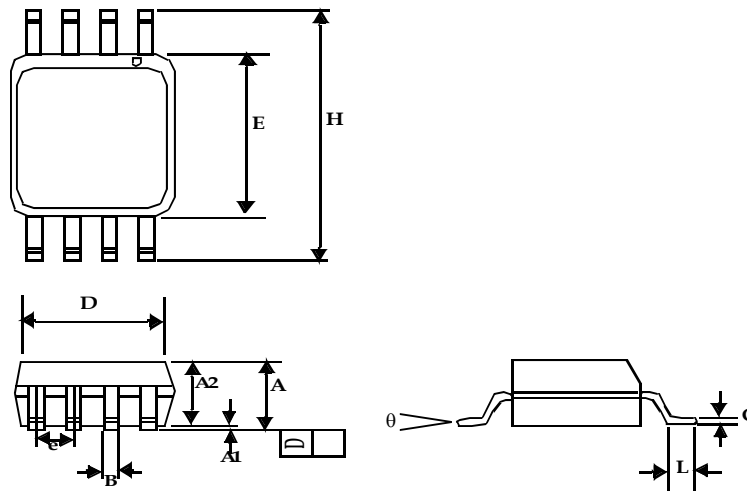

Symbol	Dimensions			
	Inches		Millimeters	
	Min	Max	Min	Max
A1	0.004	0.010	0.10	0.25
A	0.053	0.069	1.35	1.75
A2	0.049	0.059	1.25	1.50
B	0.012	0.020	0.31	0.51
C	0.007	0.010	0.18	0.25
D	0.193 BSC		4.90 BSC	
E	0.154 BSC		3.91 BSC	
e	0.050 BSC		1.27 BSC	
H	0.236 BSC		6.00 BSC	
L	0.016	0.050	0.41	1.27
θ	0°	8°	0°	8°



rev 1.6

## 8-Pin TSSOP Package

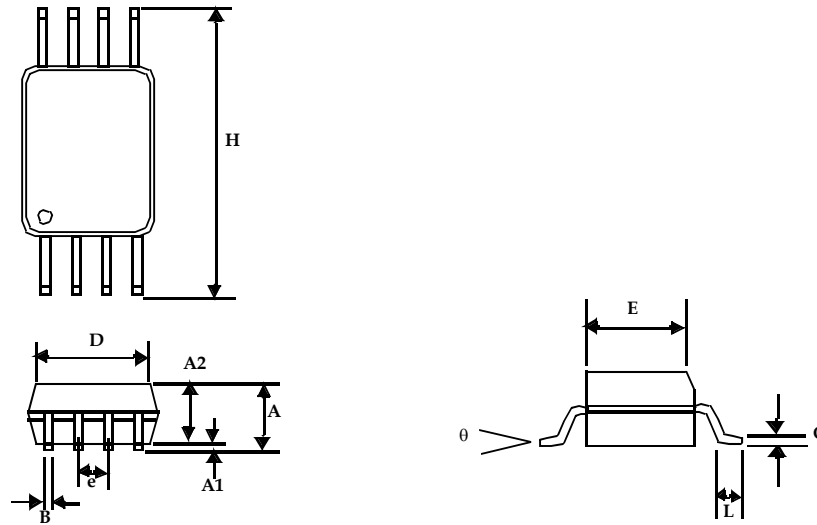

Symbol	Dimensions			
	Inches		Millimeters	
	Min	Max	Min	Max
A		0.043		1.10
A1	0.002	0.006	0.05	0.15
A2	0.033	0.037	0.85	0.95
B	0.008	0.012	0.19	0.30
c	0.004	0.008	0.09	0.20
D	0.114	0.122	2.90	3.10
E	0.169	0.177	4.30	4.50
e	0.026 BSC		0.65 BSC	
H	0.252 BSC		6.40 BSC	
L	0.020	0.028	0.50	0.70
$\theta$	0°	8°	0°	8°





rev 1.6  
Ordering Information

Part Number	Marking	Package Type	Temperature
ASM3P2669AF-06OR	H4LL	6-Pin TSOT-23, TAPE & REEL, Pb Free	Commercial
ASM3P2669AF-08TT	3P2669AF	8-Pin TSSOP, TUBE, Pb Free	Commercial
ASM3P2669AF-08TR	3P2669AF	8-Pin TSSOP, TAPE & REEL, Pb Free	Commercial
ASM3P2669AF-08ST	3P2669AF	8-Pin SOIC, TUBE, Pb Free	Commercial
ASM3P2669AF-08SR	3P2669AF	8-Pin SOIC, TAPE & REEL, Pb Free	Commercial
ASM3P2669AG-06OR	H3LL	6-Pin TSOT-23, TAPE & REEL, Green	Commercial
ASM3P2669AG-08TT	3P2669AG	8-Pin TSSOP, TUBE, Green	Commercial
ASM3P2669AG-08TR	3P2669AG	8-Pin TSSOP, TAPE & REEL, Green	Commercial
ASM3P2669AG-08ST	3P2669AG	8-Pin SOIC, TUBE, Green	Commercial
ASM3P2669AG-08SR	3P2669AG	8-Pin SOIC, TAPE & REEL, Green	Commercial
ASM3P2669A-06OR	H1LL	6-Pin TSOT-23, TAPE & REEL	Commercial
ASM3P2669A-08TT	3P2669A	8-Pin TSSOP, TUBE	Commercial
ASM3P2669A-08TR	3P2669A	8-Pin TSSOP, TAPE & REEL	Commercial
ASM3P2669A-08ST	3P2669A	8-Pin SOIC, TUBE	Commercial
ASM3P2669A-08SR	3P2669A	8-Pin SOIC, TAPE & REEL	Commercial
ASM3I2669AF-06OR	H5LL	6-Pin TSOT-23, TAPE & REEL, Pb Free	Industrial
ASM3I2669AF-08TT	3I2669AF	8-Pin TSSOP, TUBE, Pb Free	Industrial
ASM3I2669AF-08TR	3I2669AF	8-Pin TSSOP, TAPE & REEL, Pb Free	Industrial
ASM3I2669AF-08ST	3I2669AF	8-Pin SOIC, TUBE, Pb Free	Industrial
ASM3I2669AF-08SR	3I2669AF	8-Pin SOIC, TAPE & REEL, Pb Free	Industrial
ASM3I2669AG-06OR	H6LL	6-Pin TSOT-23, TAPE & REEL, Green	Industrial
ASM3I2669AG-08TT	3I2669AG	8-Pin TSSOP, TUBE, Green	Industrial
ASM3I2669AG-08TR	3I2669AG	8-Pin TSSOP, TAPE & REEL, Green	Industrial
ASM3I2669AG-08ST	3I2669AG	8-Pin SOIC, TUBE, Green	Industrial
ASM3I2669AG-08SR	3I2669AG	8-Pin SOIC, TAPE & REEL, Green	Industrial
ASM3I2669A-06OR	H2LL	6-Pin TSOT-23, TAPE & REEL	Industrial
ASM3I2669A-08TT	3I2669A	8-Pin TSSOP, TUBE	Industrial
ASM3I2669A-08TR	3I2669A	8-Pin TSSOP, TAPE & REEL	Industrial
ASM3I2669A-08ST	3I2669A	8-Pin SOIC, TUBE	Industrial
ASM3I2669A-08SR	3I2669A	8-Pin SOIC, TAPE & REEL	Industrial



rev 1.6

Device Ordering Information

A S M 3 P 2 6 6 9 A F - 0 8 T R

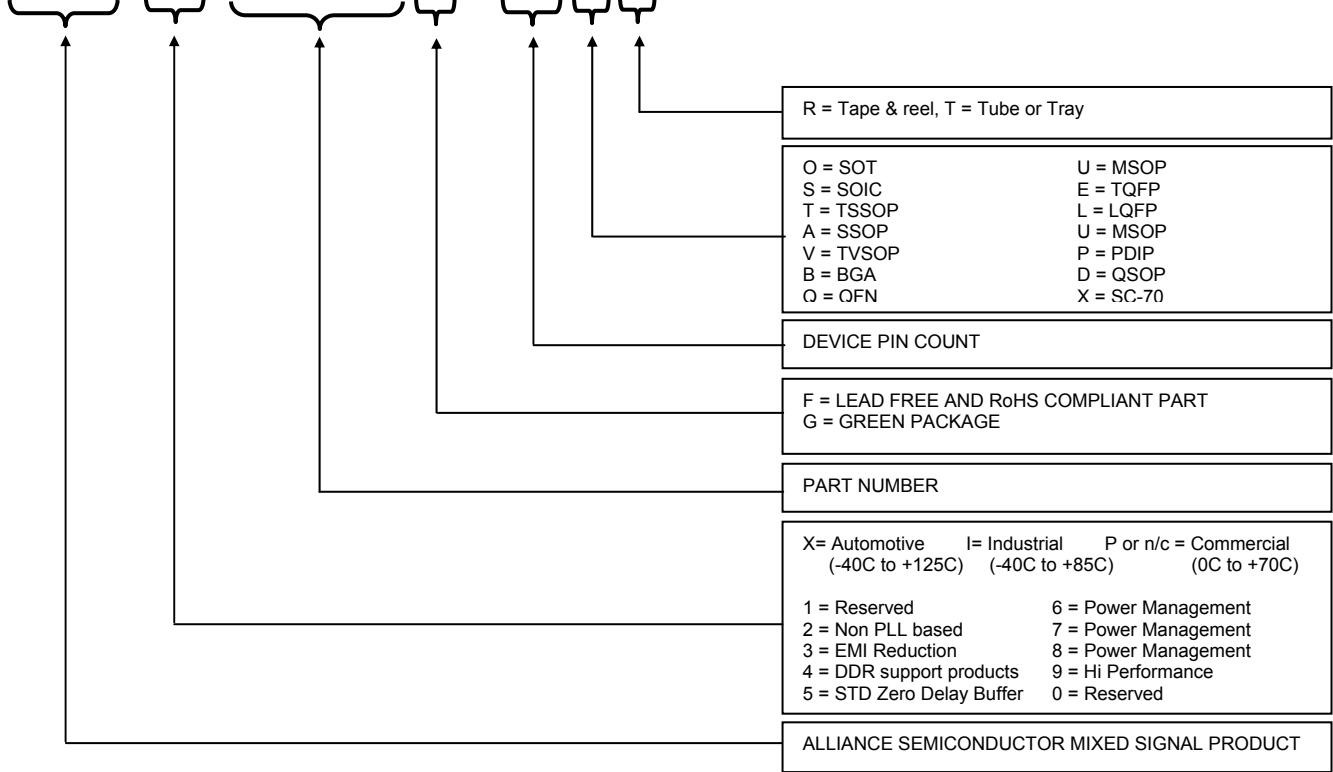

Licensed under U.S Patent Nos 5,488,627 and 5,631,921



rev 1.6



Alliance Semiconductor Corporation  
2575 Augustine Drive,  
Santa Clara, CA 95054  
Tel# 408-855-4900  
Fax: 408-855-4999  
www.alsc.com

Copyright © Alliance Semiconductor  
All Rights Reserved  
Preliminary Information  
Part Number: ASM3P2669A  
Document Version: v1.6

Note: This product utilizes US Patent # 6,646,463 Impedance Emulator Patent issued to Alliance Semiconductor, dated 11-11-2003

© Copyright 2003 Alliance Semiconductor Corporation. All rights reserved. Our three-point logo, our name and Intelliwatt are trademarks or registered trademarks of Alliance. All other brand and product names may be the trademarks of their respective companies. Alliance reserves the right to make changes to this document and its products at any time without notice. Alliance assumes no responsibility for any errors that may appear in this document. The data contained herein represents Alliance's best data and/or estimates at the time of issuance. Alliance reserves the right to change or correct this data at any time, without notice. If the product described herein is under development, significant changes to these specifications are possible. The information in this product data sheet is intended to be general descriptive information for potential customers and users, and is not intended to operate as, or provide, any guarantee or warranty to any user or customer. Alliance does not assume any responsibility or liability arising out of the application or use of any product described herein, and disclaims any express or implied warranties related to the sale and/or use of Alliance products including liability or warranties related to fitness for a particular purpose, merchantability, or infringement of any intellectual property rights, except as express agreed to in Alliance's Terms and Conditions of Sale (which are available from Alliance). All sales of Alliance products are made exclusively according to Alliance's Terms and Conditions of Sale. The purchase of products from Alliance does not convey a license under any patent rights, copyrights; mask works rights, trademarks, or any other intellectual property rights of Alliance or third parties. Alliance does not authorize its products for use as critical components in life-supporting systems where a malfunction or failure may reasonably be expected to result in significant injury to the user, and the inclusion of Alliance products in such life-supporting systems implies that the manufacturer assumes all risk of such use and agrees to indemnify Alliance against all claims arising from such use.