

Diode Full Bridge Power Module

$V_{RRM} = 1700V$
 $I_C = 200A @ T_c = 55^\circ C$

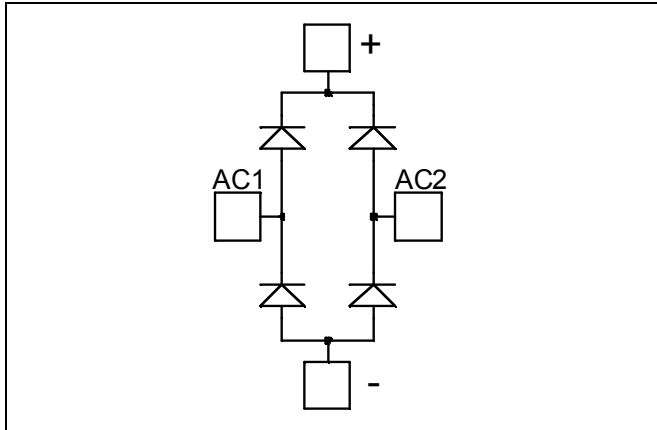

Application

- Uninterruptible Power Supply (UPS)
- Induction heating
- Welding equipment
- High speed rectifiers

Features

- Ultra fast recovery times
- Soft recovery characteristics
- High blocking voltage
- High current
- Low leakage current
- Very low stray inductance
 - Symmetrical design
 - M5 power connectors
- High level of integration

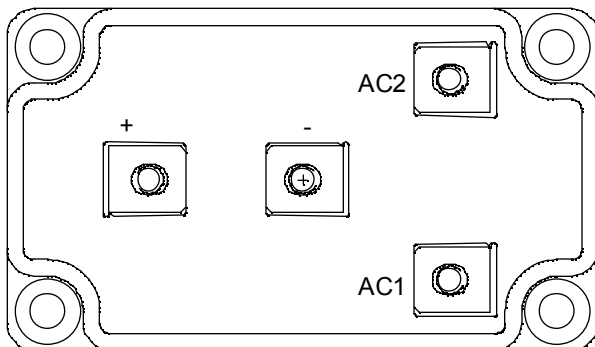

Benefits

- Outstanding performance at high frequency operation
- Low losses
- Low noise switching
- Direct mounting to heatsink (isolated package)
- Low junction to case thermal resistance
- RoHS Compliant

Absolute maximum ratings

Symbol	Parameter	Max ratings	Unit
V_R	Maximum DC reverse Voltage	1700	V
V_{RRM}	Maximum Peak Repetitive Reverse Voltage	1700	V
$I_{F(AV)}$	Maximum Average Forward Current	Duty cycle = 50% $T_c = 25^\circ C$	240
		$T_c = 55^\circ C$	200
$I_{F(RMS)}$	RMS Forward Current	250	A
I_{FSM}	Non-Repetitive Forward Surge Current	$T_j = 25^\circ C$	600

 **CAUTION:** These Devices are sensitive to Electrostatic Discharge. Proper Handling Procedures Should Be Followed. See application note APT0502 on www.microsemi.com

All ratings @ $T_j = 25^\circ\text{C}$ unless otherwise specified

Electrical Characteristics

Symbol	Characteristic	Test Conditions	Min	Typ	Max	Unit	
V_F	Diode Forward Voltage	$I_F = 200\text{A}$	$T_j = 25^\circ\text{C}$		2.2	2.5	V
			$T_j = 125^\circ\text{C}$		2.1		
I_{RM}	Maximum Reverse Leakage Current	$V_R = 1700\text{V}$	$T_j = 25^\circ\text{C}$			350	μA
			$T_j = 125^\circ\text{C}$			600	

Dynamic Characteristics

Symbol	Characteristic	Test Conditions	Min	Typ	Max	Unit	
t_{rr}	Reverse Recovery Time	$I_F = 200\text{A}$ $V_R = 900\text{V}$ $di/dt = 2000\text{A}/\mu\text{s}$	$T_j = 25^\circ\text{C}$		572		ns
			$T_j = 125^\circ\text{C}$		704		
Q_{rr}	Reverse Recovery Charge		$T_j = 25^\circ\text{C}$		40		μC
			$T_j = 125^\circ\text{C}$		70		
I_{RRM}	Reverse Recovery Current		$T_j = 25^\circ\text{C}$		140		A
			$T_j = 125^\circ\text{C}$		200		

Thermal and package characteristics

Symbol	Characteristic	Min	Typ	Max	Unit	
R_{thJC}	Junction to Case Thermal Resistance			0.18	$^\circ\text{C}/\text{W}$	
V_{ISOL}	RMS Isolation Voltage, any terminal to case $t = 1\text{ min}$, $I_{isol} < 1\text{mA}$, 50/60Hz	3500			V	
T_J	Operating junction temperature range	-40		150	$^\circ\text{C}$	
T_{STG}	Storage Temperature Range	-40		125		
T_C	Operating Case Temperature	-40		100		
Torque	Mounting torque	To heatsink	M6	3	5	N.m
		For terminals	M5	2	3.5	
Wt	Package Weight			280	g	

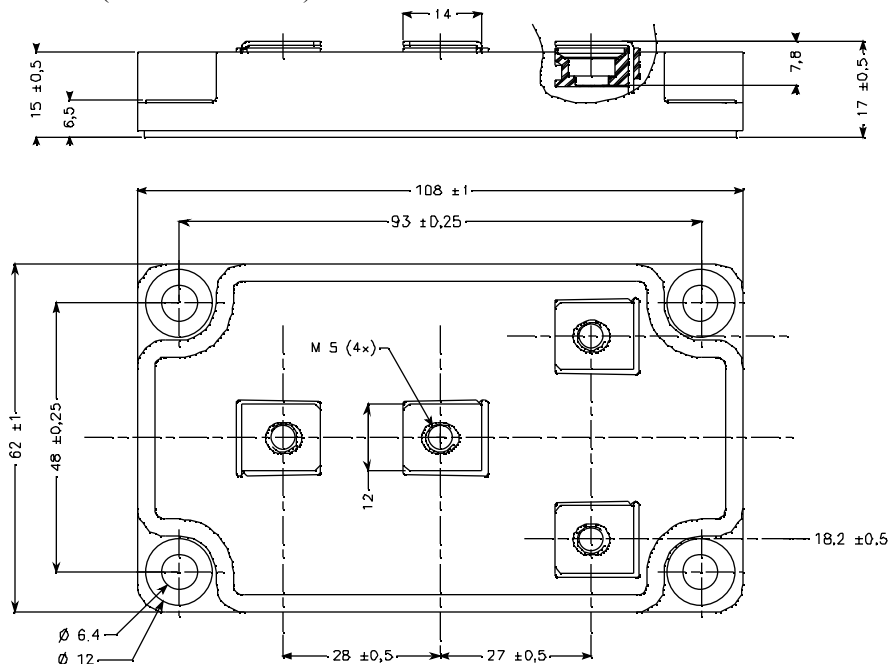
SP6 Package outline (dimensions in mm)

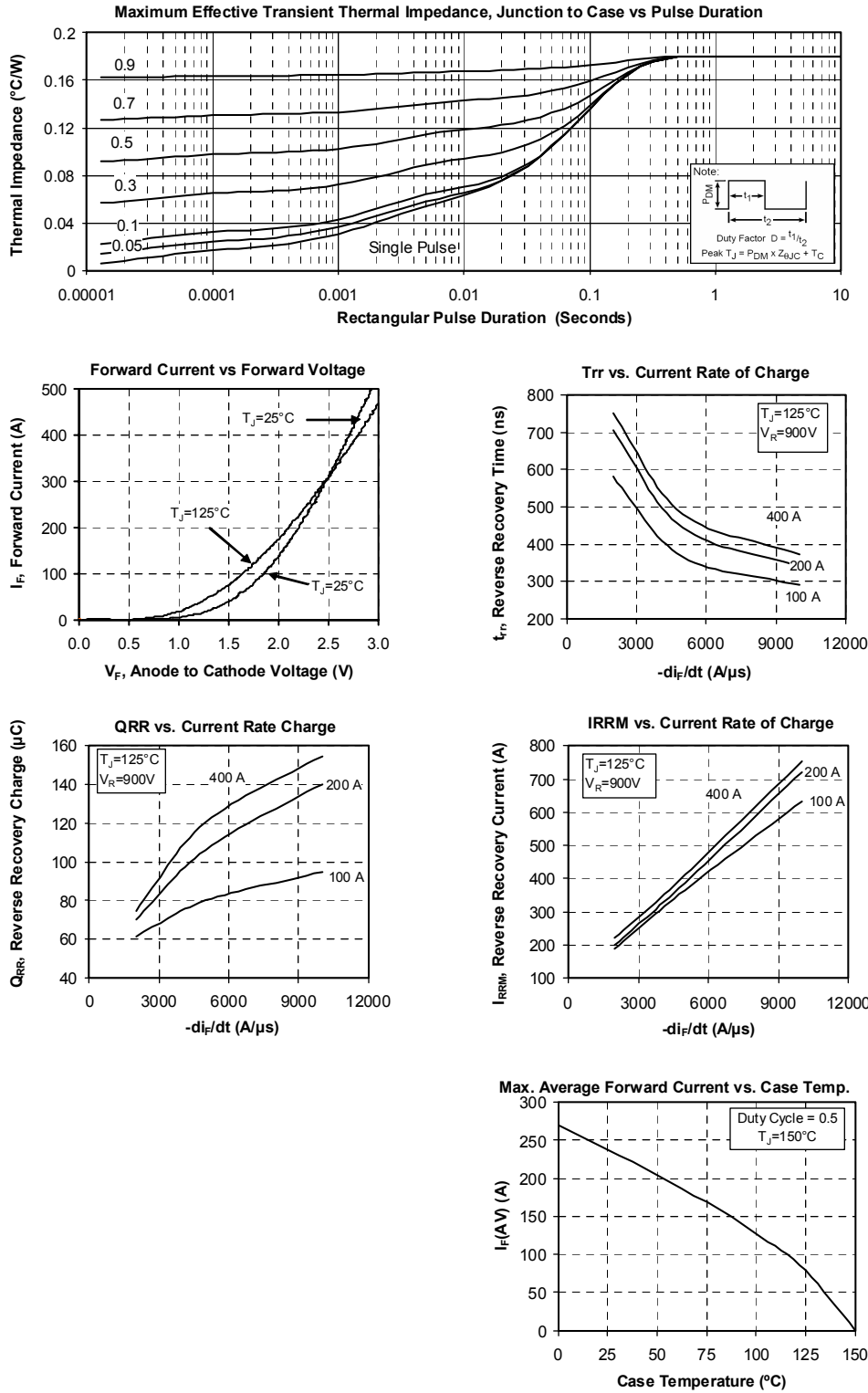
Typical Performance Curve

Microsemi reserves the right to change, without notice, the specifications and information contained herein

Microsemi's products are covered by one or more of U.S. patents 4,895,810 5,045,903 5,089,434 5,182,234 5,019,522 5,262,336 6,503,786 5,256,583 4,748,103 5,283,202 5,231,474 5,434,095 5,528,058 and foreign patents. U.S. and Foreign patents pending. All Rights Reserved.