

AM2520EH/xx5V SERIES

Features

- HIGH RELIABILITY
- BLACK CASE ENHANCES CONTRAST.
- VIBRATION AND SHOCK RESISTANT.
- AVAILABLE WITH A VARIETY OF LEDs.
- UL RATING : 94V-0.
- HOUSING MATERIAL: TYPE 66 NYLON.

Description

The High Efficiency Red source color devices are made with Gallium Arsenide Phosphide on Gallium Phosphide Orange Light Emitting Diode.

The Super Bright Green source color devices are made with Gallium Phosphide Green Light Emitting Diode.

The Yellow source color devices are made with Gallium Arsenide Phosphide on Gallium Phosphide Yellow Light Emitting Diode.

Package Dimensions

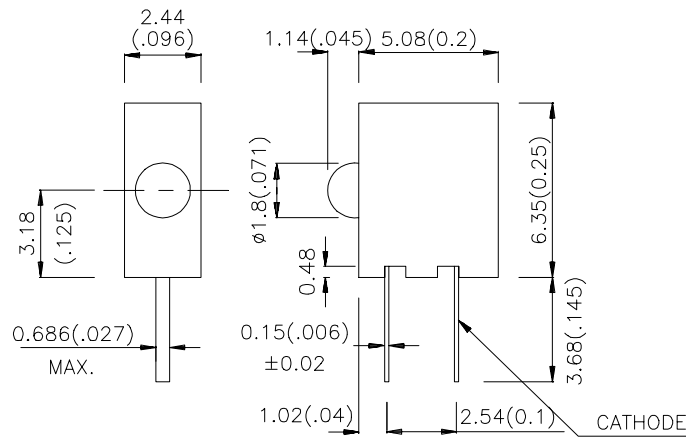

Notes:

1. All dimensions are in millimeters (inches).
2. Tolerance is $\pm 0.25(0.01)$ unless otherwise noted.
3. Lead spacing is measured where the lead emerge package.
4. Specifications are subject to change without notice.

Selection Guide

Part No.	Dice	Lens Type	Iv (mcd) V=5V		Viewing Angle
			Min.	Typ.	2θ1/2
AM2520EH/ID5V	HIGH EFFICIENCY RED (GaAsP/GaP)	RED DIFFUSED	3	8	40°
AM2520EH/YD5V	YELLOW (GaAsP/GaP)	YELLOW DIFFUSED	2	3	40°
AM2520EH/SGD5V	SUPER BRIGHT GREEN (GaP)	GREEN DIFFUSED	2	4	40°

Note:

1. $\theta 1/2$ is the angle from optical centerline where the luminous intensity is 1/2 the optical centerline value.

Electrical / Optical Characteristics at T_A=25°C For 5V

Symbol	Parameter	Device	Typ.	Max.	Units	Test Conditions
λ_{peak}	Peak Wavelength	High Efficiency Red Super Bright Green Yellow	627 565 590		nm	VF=5V
λ_D	Dominate Wavelength	High Efficiency Red Super Bright Green Yellow	625 568 588		nm	VF=5V
$\Delta\lambda_{1/2}$	Spectral Line Halfwidth	High Efficiency Red Super Bright Green Yellow	45 30 35		nm	VF=5V
I_F	Forward Current	High Efficiency Red Super Bright Green Yellow	13 13 13		mA	VF=5V
I_R	Reverse Current	All		10	uA	VR = 5V

Absolute Maximum Ratings at T_A=25°C For 5V

Parameter	High Efficiency Red	Super Bright Green	Yellow	Units
Power dissipation	85	85	85	mW
DC Forward Voltage	6.5	6.5	6.5	V
Reverse Voltage	5	5	5	V
Operating Temperature	-40°C To +70°C			
Storage Temperature	-40°C To +85°C			
Lead Solder Temperature[1]	260°C For 5 Seconds			

Notes:

- 1/0 Duty Cycle, 0.1ms Pulse Width.
- 4mm below package base.

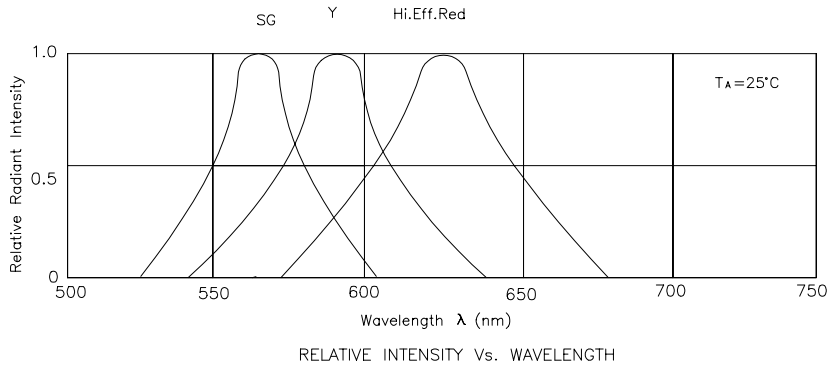

High Efficiency Red AM2520EH/ID5V

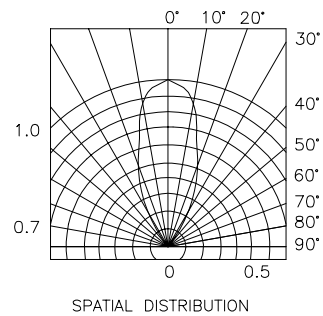
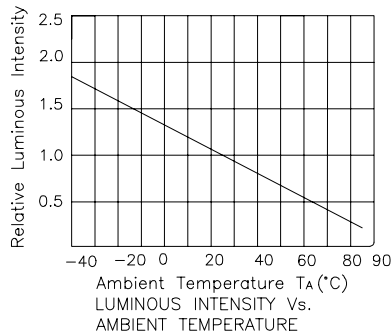
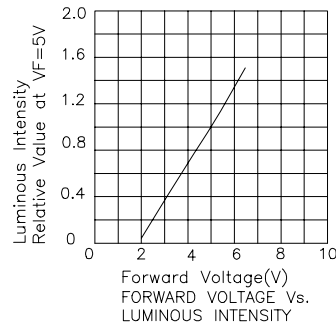
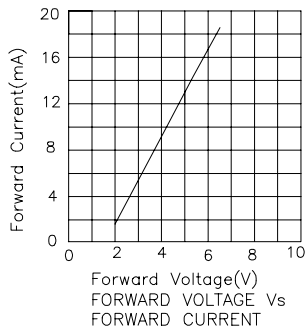

Super Bright Green AM2520EH/SGD5V

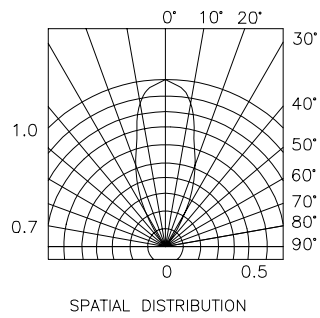
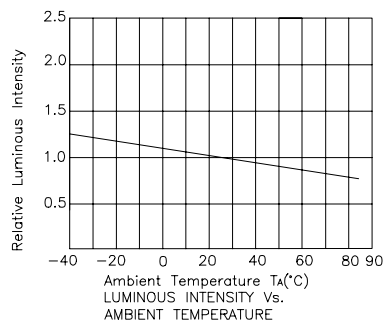
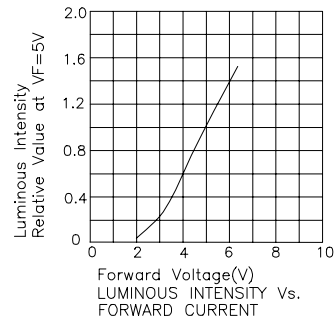
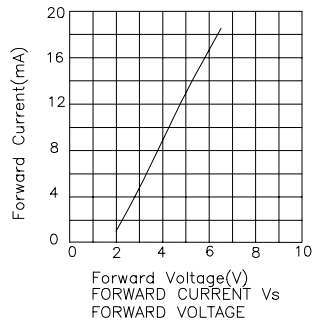

Yellow AM2520EH/YD5V

