

White LED Step-Up Converter in SOT23

FEATURES

- 1.2MHz Fixed Frequency Current-Mode PWM Operation.
- Efficiency Up to 84% at $V_{IN}=4.2V$, 3LEDs, $I_{LED}=20mA$
- Drives Up to 6LEDs in series
- Low Supply Current: $70\mu A$
- Matches LED Current
- Require Tiny Inductors and Capacitors
- Tiny SOT23-5 Package

APPLICATIONS

- Cellular Phones
- PDAs
- Digital Still Cameras
- Handheld Devices
- White LED Display Backlighting

DESCRIPTION

AIC1647 is a fixed frequency step-up DC/DC converter designed to drive white LEDs with a constant current to provide backlight in hand-held devices. Series connection of the LEDs provides identical LED currents resulting in uniform brightness. This configuration eliminates the need for ballast resistors. Low 95mV feedback voltage minimizes power loss in the current setting resistor for better efficiency.

AIC1647 is a step-up PWM converter, which includes an internal N-channel MOSFET switch for high efficiency. The high switching frequency, 1.2MHz, allows the use of tiny external components, saves the layout space and cost.

AIC1647 is available in a space-saving, 5-lead SOT-23-5 package.

TYPICAL APPLICATION CIRCUIT

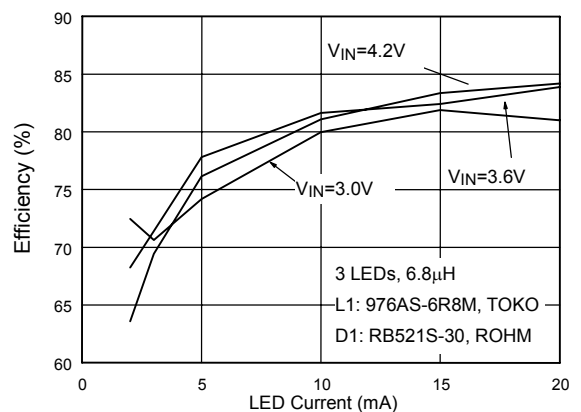
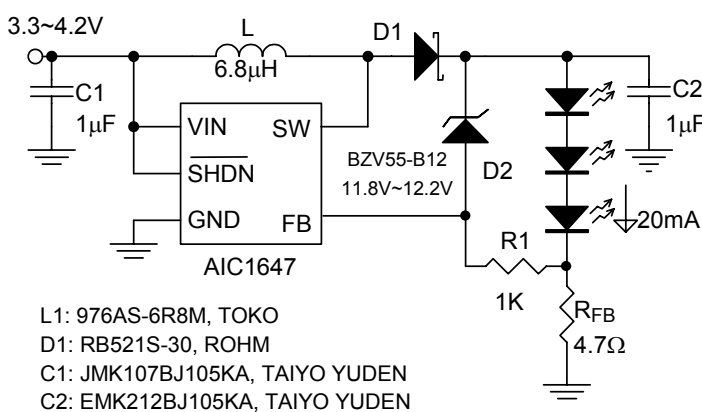
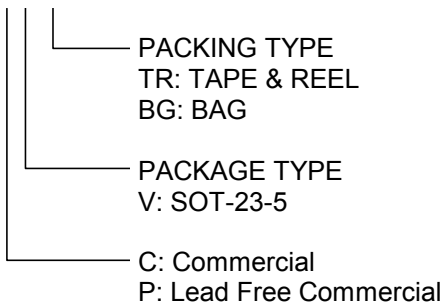
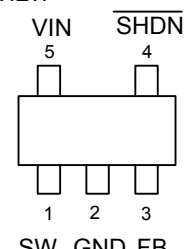

Fig. 1 Li-Ion Powered Driver with Over Voltage Protection for Three White LEDs

ORDERING INFORMATION

AIC1647XXXX



| ORDER NUMBER | PIN CONFIGURATION |
|----------------------------|---|
| AIC1647CV&PV (SOT-23-5) | FRONT VIEW  VIN 5 SHDN 4 1 2 3 SW GND FB |

Example: AIC1647CVTR
 → in SOT-23-5 Package & Tape & Reel Packing Type

MARKING

| Part No. | CV | PV |
|----------|------|-------|
| AIC1647 | 1647 | 1647P |

ABSOLUTE MAXIMUM RATINGS

| | |
|--|----------------|
| Input Voltage (VIN) | 6V |
| SW Voltage | 33V |
| FB Voltage | 6V |
| SHDN Voltage | 6V |
| Operating Temperature Range | -40°C to 85°C |
| Maximum Junction Temperature | 125°C |
| Storage Temperature Range | -65°C to 150°C |
| Lead Temperature (Soldering, 10 sec) | 260°C |

Absolute Maximum Ratings are those values beyond which the life of a device may be impaired.

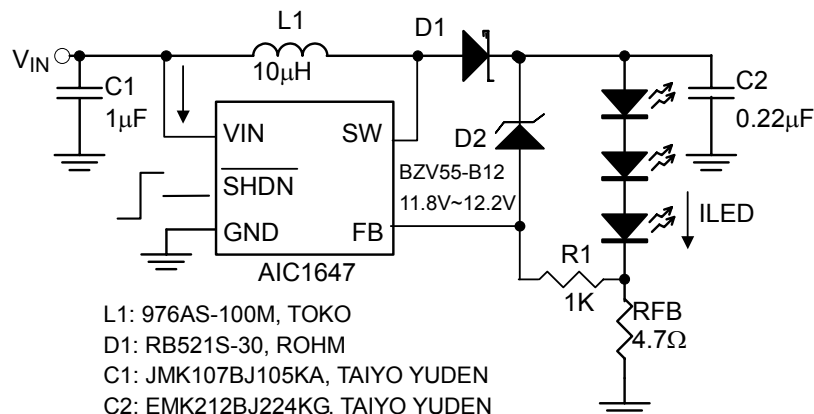
TEST CIRCUIT

ELECTRICAL CHARACTERISTICS

 ($V_{\overline{\text{SHDN}}}=3\text{V}$, $V_{\text{IN}}=3\text{V}$, $T_{\text{A}}=25^{\circ}\text{C}$, unless otherwise specified.) (Note 1)

| PARAMETER | SYMBOL | TEST CONDITIONS | MIN | TYP | MAX | UNIT |
|---------------------------------------|----------------------|--|-----|-----|-----|---------------|
| Minimum Operating Voltage | V_{IN} | | 2.5 | | | V |
| Maximum Operating Voltage | V_{IN} | | | | 5.5 | V |
| Supply Current | I_{IN} | Switching | | 1 | 5 | mA |
| | | Non switching | | 70 | 100 | μA |
| | | $V_{\overline{\text{SHDN}}}=0\text{V}$ | | 0.1 | 1.0 | |
| ERROR AMPLIFIER | | | | | | |
| Feedback Voltage | V_{FB} | | 85 | 95 | 105 | mV |
| FB Input Bias Current | I_{FB} | $V_{\text{FB}}=95\text{mV}$ | | 1 | | nA |
| OSCILLATOR | | | | | | |
| Switching Frequency | f_{OSC} | | 0.8 | 1.2 | 1.6 | MHz |
| Maximum Duty Cycle | DC | | 85 | 90 | | % |
| POWER SWITCH | | | | | | |
| SW ON Resistance | $R_{\text{DS(ON)}}$ | | | 1.4 | 5 | Ω |
| Switch Leakage Current | $I_{\text{SW(OFF)}}$ | $V_{\text{SW}}=33\text{V}$ | | 0.1 | 1 | μA |
| CONTROL INPUT | | | | | | |
| $\overline{\text{SHDN}}$ Voltage High | V_{IH} | ON | 1.5 | | | V |
| $\overline{\text{SHDN}}$ Voltage Low | V_{IL} | OFF | | | 0.3 | V |

Note 1: Specifications are production tested at $T_{\text{A}}=25^{\circ}\text{C}$. Specifications over the -40°C to 85°C operating temperature range are assured by design, characterization and correlation with Statistical Quality Controls (SQC).

TYPICAL PERFORMANCE CHARACTERISTICS

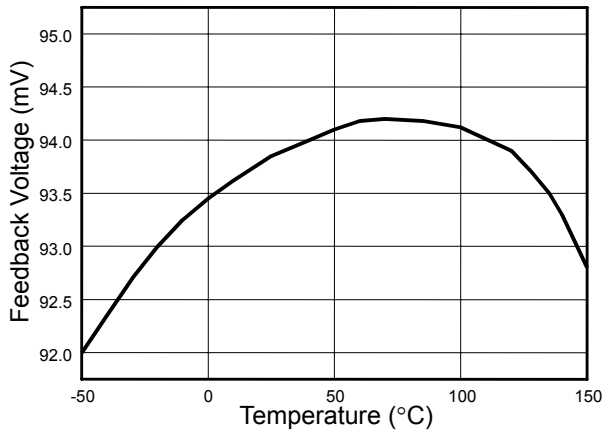

Fig. 2 Feedback Voltage vs. Temperature

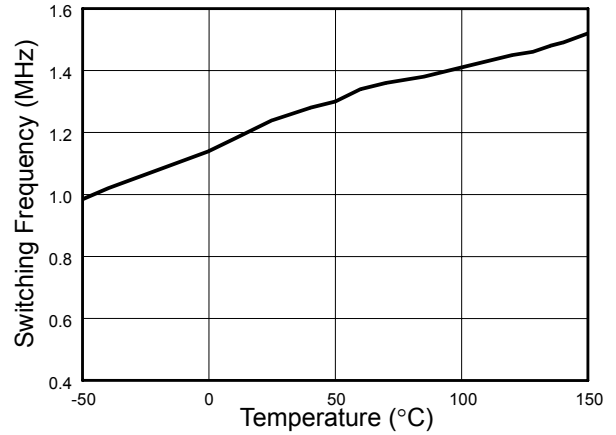

Fig. 3 Switching Frequency vs. Temperature

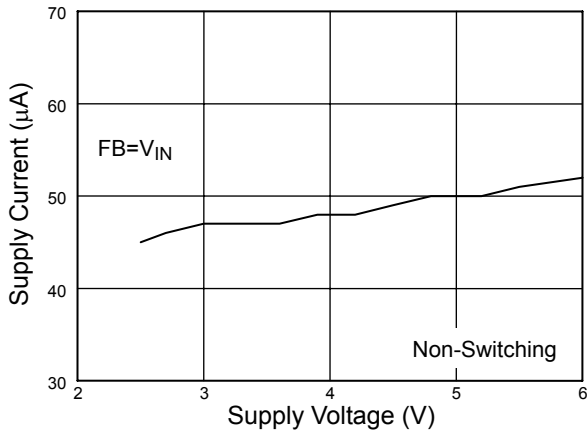

Fig. 4 Supply Current vs. Supply Voltage

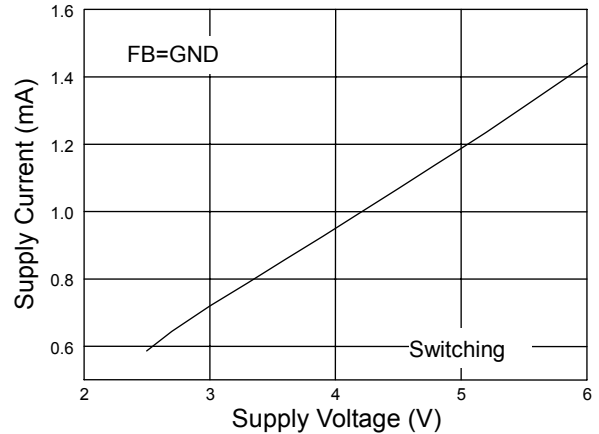

Fig. 5 Supply Current vs. Supply Voltage

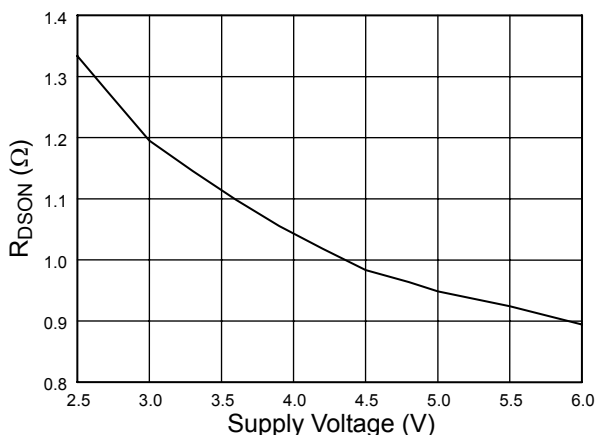

Fig. 6 R_{DS-ON} vs. Supply Voltage

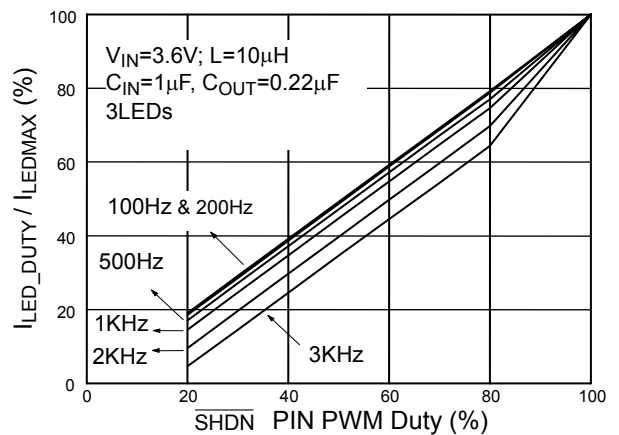

Fig. 7 Dimming Control by Shutdown PIN

■ TYPICAL PERFORMANCE CHARACTERISTICS (Continued)

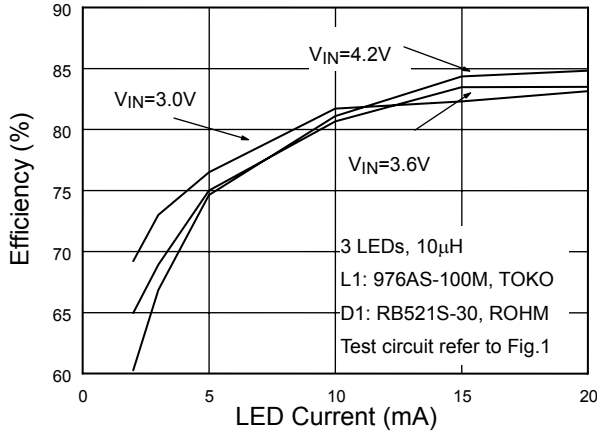

Fig. 8 3 LEDs Efficiency vs. LED Current

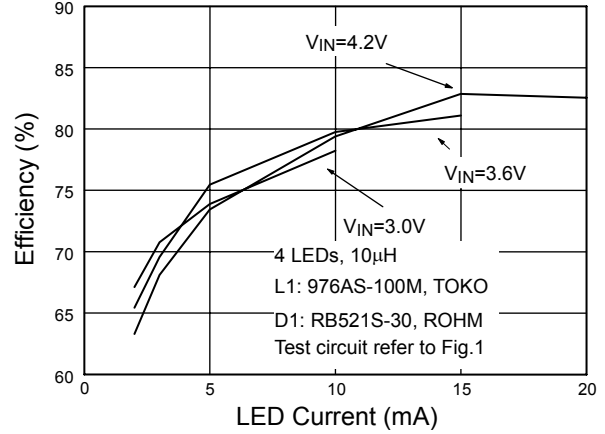

Fig. 9 4 LEDs Efficiency vs. LED Current

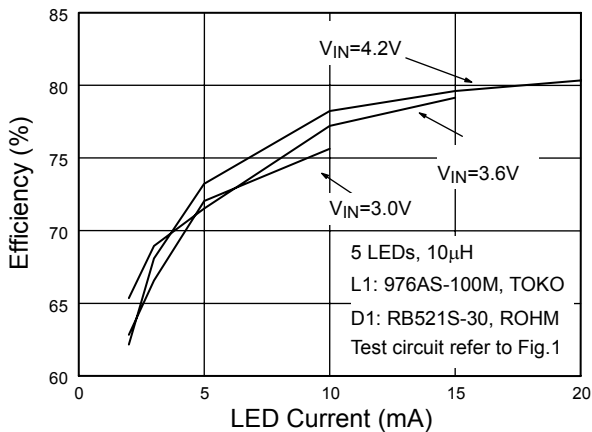

Fig. 10 5 LEDs Efficiency vs. LED Current

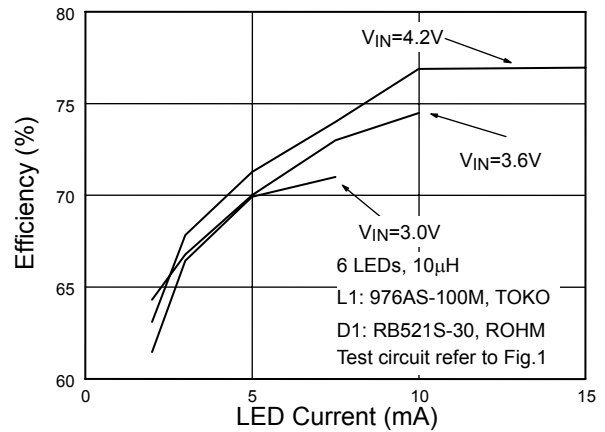

Fig. 11 6 LEDs Efficiency vs. LED Current

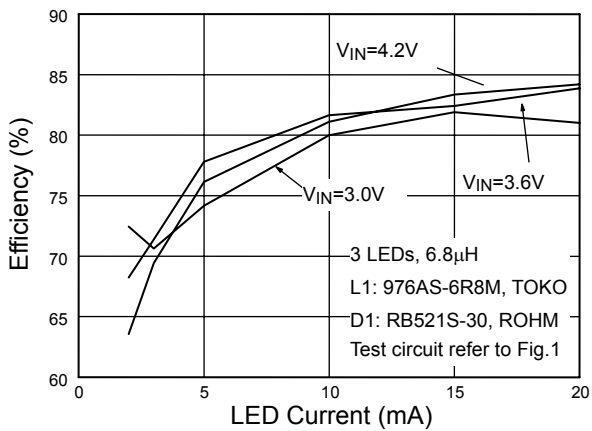

Fig. 12 3 LEDs Efficiency vs. LED Current

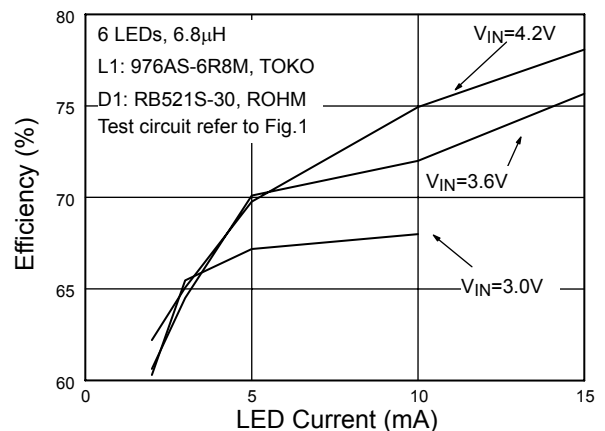

Fig. 13 6 LEDs Efficiency vs. LED Current

TYPICAL PERFORMANCE CHARACTERISTICS (Continued)

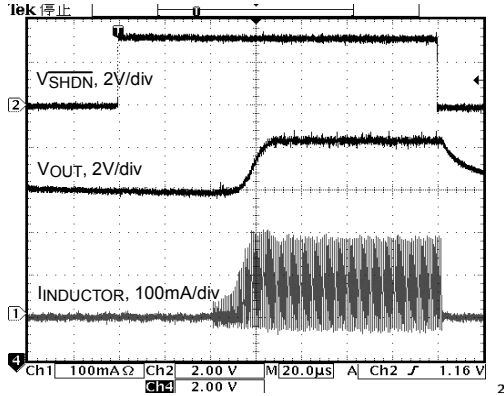

Fig. 14 Start-Up from Shutdown
 $V_{IN}=3.6V$; 3 LEDs; $L_1=10\mu F$; $C_{OUT}=0.22\mu F$; $I_{LED}=20mA$

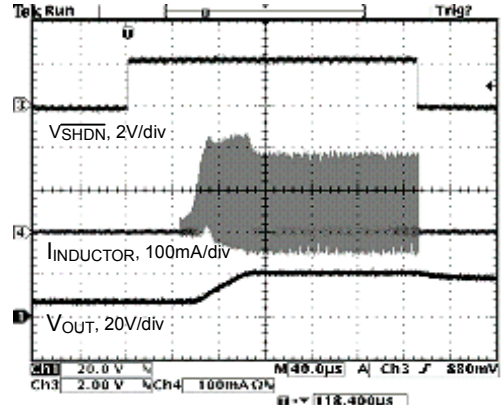

Fig. 15 Start-Up from Shutdown
 $V_{IN}=3.6V$; 6 LEDs; $L_1=10\mu F$; $C_{OUT}=0.22\mu F$; $I_{LED}=10mA$

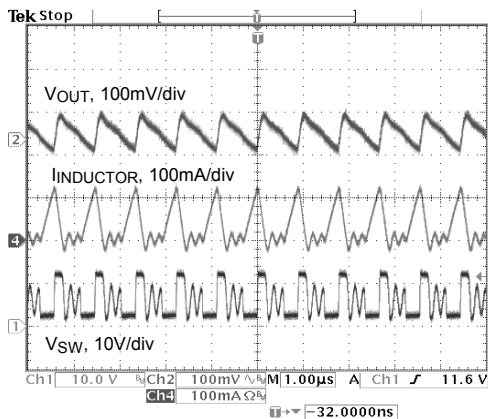

Fig. 16 Operation Wave Form
 $V_{IN}=3.6V$; 3 LEDs; $L_1=10\mu F$; $C_{OUT}=0.22\mu F$; $I_{LED}=10mA$

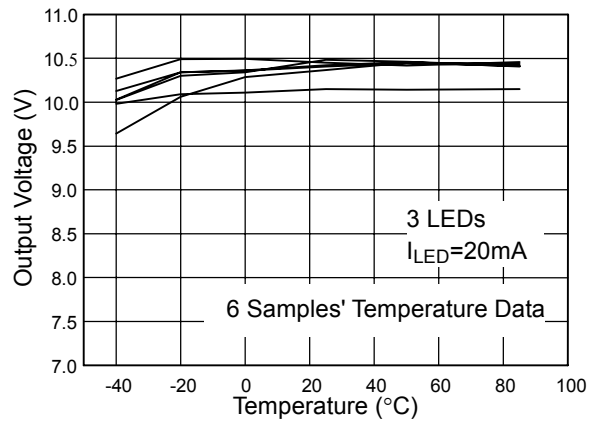

Fig. 17 Output voltage vs. temperature

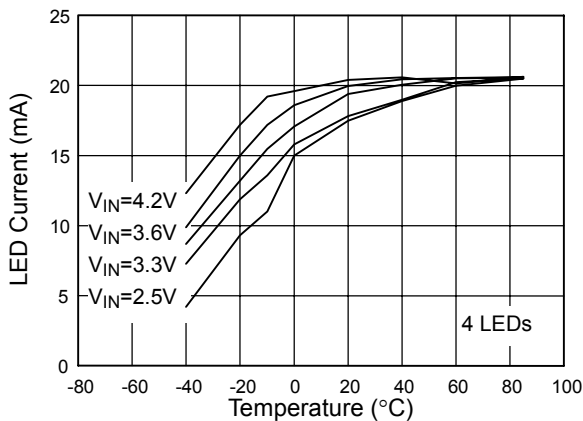
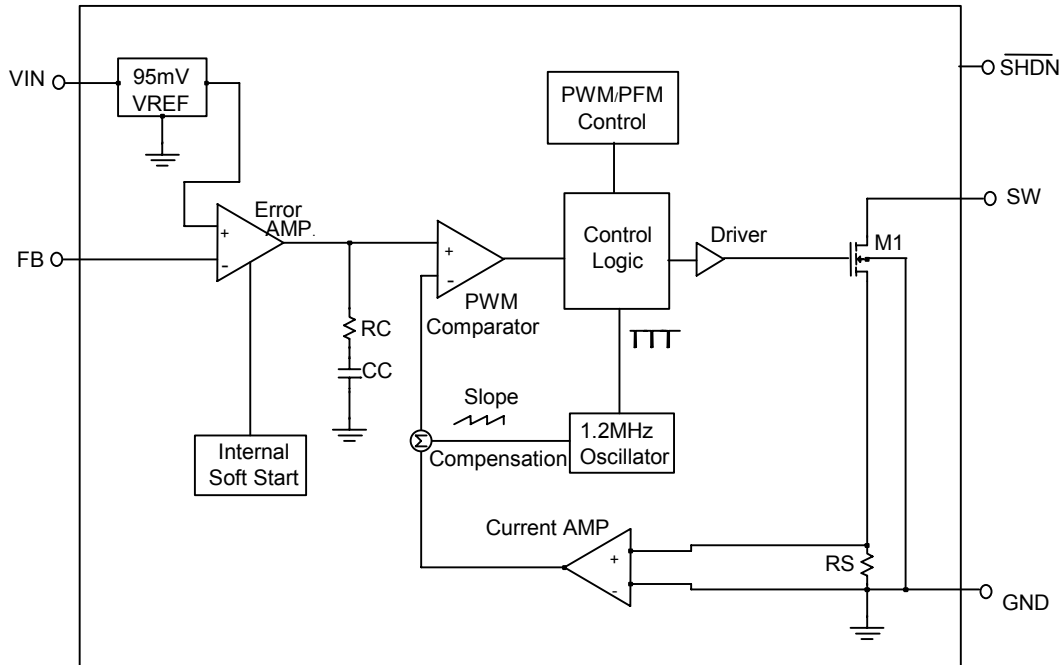

Fig. 18 LED Current vs. Temperature

■ BLOCK DIAGRAM



■ PIN DESCRIPTIONS

- PIN 1: SW - Switch Pin. Connect inductor/diode here. Minimize trace area at this pin to reduce EMI.
- PIN 2: GND - Ground Pin. Tie directly to local ground plane.
- PIN 3: FB - Feedback Pin. Reference voltage is 95mV. Connect cathode of lowest LED and

resistor here. Calculate resistor value according to the formula:

$$R_{FB} = 95\text{mV}/I_{LED}$$

- PIN 4: $\overline{\text{SHDN}}$ - Shutdown pin. Tie to higher than 1.5V to enable device, 0.3V or less to disable device.

- PIN 5: VIN - Power input pin. Bypass VIN to GND with a capacitor sitting as close to VIN as possible.

■ APPLICATION INFORMATION

Inductor Selection

A 10 μ H inductor is recommended for most AIC1647 applications. Although small size and high efficiency are major concerns, the inductor should have low core losses at 1.2MHz and low DCR (copper wire resistance).

Capacitor Selection

The small size of ceramic capacitors makes them ideal for AIC1647 applications. X5R and X7R types are recommended because they retain their capacitance over wider ranges of voltage and temperature than other types, such as Y5V or Z5U. 1 μ F input capacitor with 1 μ F output capacitor are sufficient for most AIC1647 applications.

Diode Selection

Schottky diodes, with their low forward voltage drop and fast reverse recovery, are the ideal choices for AIC1647 applications. The forward voltage drop of a Schottky diode represents the conduction losses in the diode, while the diode capacitance (CT or CD) represents the switching losses. For diode selection, both forward voltage drop and diode capacitance need to be considered. Schottky diodes with higher current ratings usually have lower forward voltage drop and larger diode capacitance, which can cause significant switching losses at the 1.2MHz switching frequency of AIC1647. An Schottky diode rated at 100mA to 200mA is sufficient for most AIC1647 applications.

LED Current Control

LED current is controlled by feedback resistor (R_{FB} in Fig. 1). The feedback reference voltage is 95mV. The LED current is $95\text{mV}/R_{FB}$. In order to have accurate LED current, precision resistors are preferred (1% recommended). The formula for R_{FB} selection is shown below.

$$R_{FB} = 95\text{mV}/I_{LED}$$

Open-Circuit Protection

In the cases of output open circuit, when the LEDs are disconnected from the circuit or the LEDs fail, the feedback voltage will be zero. AIC1647 will then switch to a high duty cycle resulting in a high output voltage, which may cause SW pin voltage to exceed its maximum 33V rating. A zener diode can be used at the output to limit the voltage on SW pin (Figure 1). The zener voltage should be larger than the maximum forward voltage of the LED string. The current rating of the zener should be larger than 0.1mA.

Dimming Control

There are three different ways of dimming control circuits as follows:

1. Using a PWM Signal

PWM brightness control provides the widest dimming range by pulsing the LEDs on and off at full and zero current, respectively. The change of average LED current depends on the duty cycle of the PWM signal. Typically, a 0.1kHz to 1kHz PWM signal is used. Two applications of PWM dimming with AIC1647 are shown in Figure 19 and Figure 20. One, as Figure 19, uses PWM signal to drive SHDN pin directly for dimming control. The other, as Figure 20, employs PWM signal going through a resistor to drive FB pin. If the SHDN pin is used, the increase of duty cycle results in LED brightness enhancement. If the FB pin is used, on the contrary, the increase of duty cycle will decrease its brightness. In this application, LEDs are dimmed by FB pin and turned off completely by SHDN.

2. Using a DC Voltage

For some applications, the preferred method of a dimming control uses a variable DC voltage to adjust LED current. The dimming control using a DC voltage is shown in Figure 21. Cautiously selecting R1 and R2 is essential so that the current from the variable DC source is much smaller than the LED current and much larger

than the FB pin bias current. With a VDC ranging from 0V to 5V, the selection of resistors in Figure 21 results in dimming control of LED current from 20mA to 0mA, respectively.

3. Using a Filtered PWM Signal

Filtered PWM signal can be considered as an adjustable DC voltage. It can be used to replace the variable DC voltage source in dimming control. The circuit is shown in Figure 22.

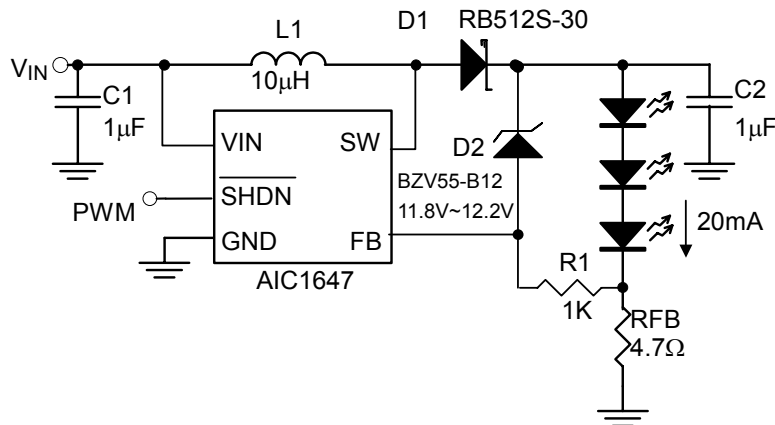

Fig. 19 Dimming Control Using a PWM Signal with Open-Circuit Protection

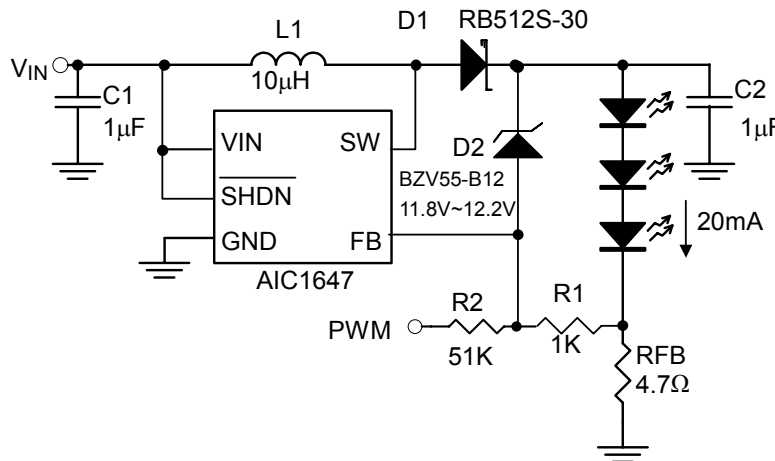

Fig. 20 Dimming Control Using a PWM Signal

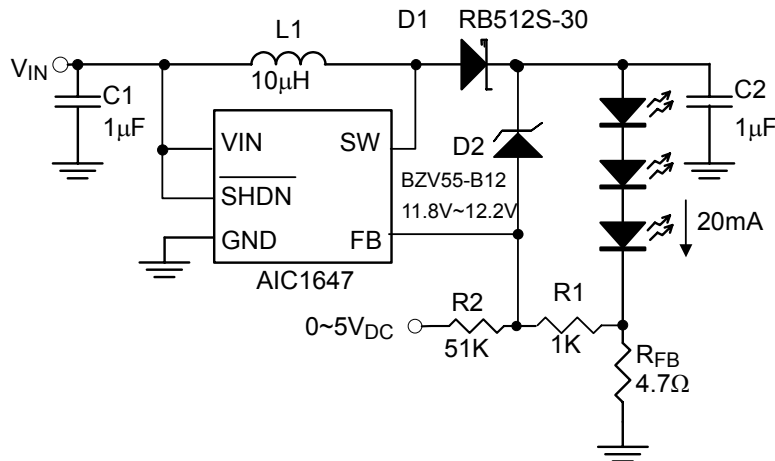

Fig. 21 Dimming Control Using a DC Voltage

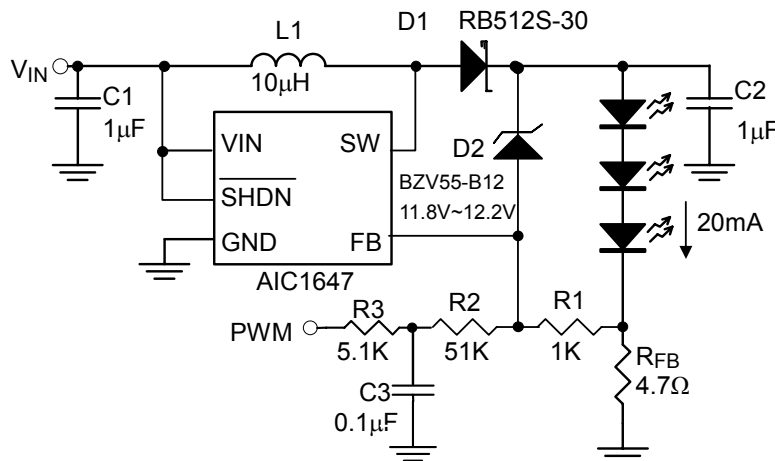

Fig. 22 Dimming Control Using a Filter PWM Signal

■ APPLICATION EXAMPLE

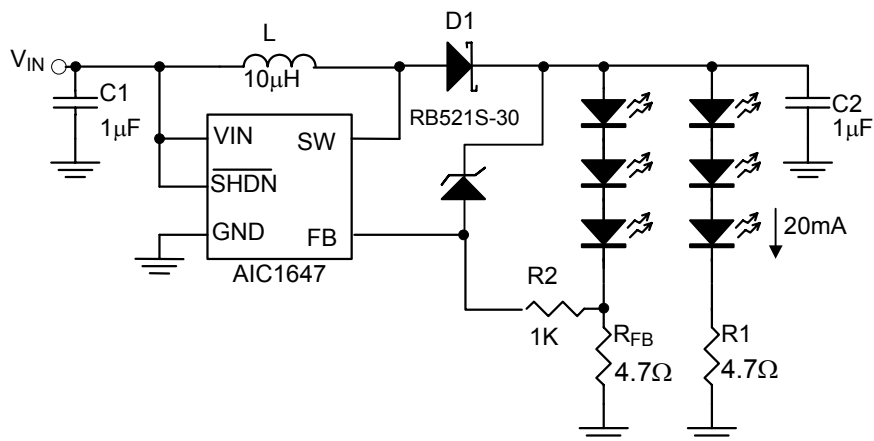
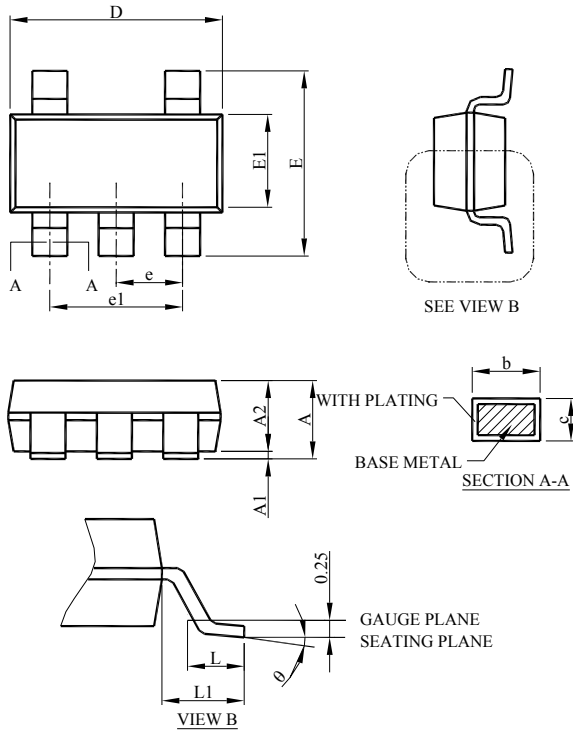

Fig. 23 Six white LEDs application in Li-Ion Battery

■ PHYSICAL DIMENSIONS (unit: mm)

● SOT-23-5



| SYMBOL | SOT-25 | |
|----------|-------------|------|
| | MILLIMETERS | |
| | MIN. | MAX. |
| A | 0.95 | 1.45 |
| A1 | 0.05 | 0.15 |
| A2 | 0.90 | 1.30 |
| b | 0.30 | 0.50 |
| c | 0.08 | 0.22 |
| D | 2.80 | 3.00 |
| E | 2.60 | 3.00 |
| E1 | 1.50 | 1.70 |
| e | 0.95 BSC | |
| e1 | 1.90 BSC | |
| L | 0.30 | 0.60 |
| L1 | 0.60 REF | |
| θ | 0° | 8° |

Note:

Information provided by AIC is believed to be accurate and reliable. However, we cannot assume responsibility for use of any circuitry other than circuitry entirely embodied in an AIC product; nor for any infringement of patents or other rights of third parties that may result from its use. We reserve the right to change the circuitry and specifications without notice.

Life Support Policy: AIC does not authorize any AIC product for use in life support devices and/or systems. Life support devices or systems are devices or systems which, (i) are intended for surgical implant into the body or (ii) support or sustain life, and whose failure to perform, when properly used in accordance with instructions for use provided in the labeling, can be reasonably expected to result in a significant injury to the user.