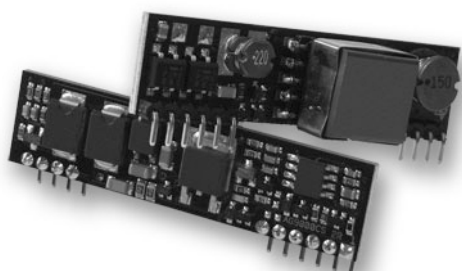




# Ag9000-S

## Power-Over-Ethernet Module



### 1. Features

- IEEE802.3af compliant
- Small SIL package size - 56mm (L) x 14mm (H)
- Low output ripple and noise
- Input voltage range 36V to 60V
- Only one low cost external decoupling capacitor required
- Overload and short-circuit protection
- Adjustable Output
- High efficiency DC/DC converter
- 1500V isolation (input to output)
- Silver Telecom “design-in” assistance

### 2. Description

The Ag9000-S series of modules are designed to extract power from a conventional twisted pair Category 5 Ethernet cable, conforming to the IEEE 802.3af Power-over-Ethernet (PoE) standard.

IEEE 802.3af allows for two power options for Category 5 cables and the Ag9000-S series have two pairs of power inputs pins: - VA1&2 and VB1&2 to accommodate this, see Figure 1.

The Ag9000-S signature and control circuit provides the PoE compatibility signature and power classification required by the Power Sourcing Equipment (PSE) before applying up to 15W power to the port. The Ag9000 is compatible with Class 0 to Class 3 equipment.

The high efficiency DC/DC converter operates over a wide input voltage range and provides a regulated low ripple and low noise output. The DC/DC converter also has built-in overload and short-circuit output protection.

## Table of Contents

1. Features.....	1
2. Description.....	1
Table of Contents.....	2
Table of Figures.....	2
3. Ag9000-S Product Selector.....	2
4. Pin Description.....	4
5. Functional Description.....	5
5.1. Inputs.....	5
5.2. PD Signature.....	5
5.3. Isolation.....	5
5.4. Power Classification.....	6
5.5. DC/DC Converter.....	7
5.6. Output Adjustment.....	7
5.7. Typical Connections.....	8
6. Typical Application.....	9
7. Typical Recommendations.....	10
8. Operating Temperature Range.....	10
9. Electrical Characteristics.....	13
9.1. Absolute Maximum Ratings*.....	13
9.2. Recommended Operating Conditions.....	13
9.3. DC Electrical Characteristics*.....	13
10. Package.....	14
10.1. Ag9000-S.....	14

## Table of Figures

Figure 1: Block Diagram.....	3
Figure 2: Ag9000-S Package Format.....	3
Figure 3: Typical System Diagram.....	5
Figure 4: Class Programming Option.....	6
Figure 5: Output Adjustment.....	7
Figure 6: Typical Connection Diagram.....	8
Figure 7: Typical Application.....	9
Figure 8: Typical Layout.....	10
Figure 9: Power Plane Heatsink for Ag9000-S.....	11
Figure 10: Ag9033-S Operating Profile.....	11
Figure 11: Ag9050-S Operating Profile.....	12
Figure 12: Ag9120-S Operating Profile.....	12

## 3. Ag9000-S Product Selector

Part Number†	Nominal Output Voltage	Maximum Output Power *	Marking
Ag9120-S	12.0V	12 Watts	12
Ag9050-S	5.0V	9 Watts	5
Ag9033-S	3.3V	6 Watts	3

\*At 25°C with  $V_{IN} = 48V$

† All versions of the Ag9000 are RoHS compliant.

**Table 1: Ordering Information**

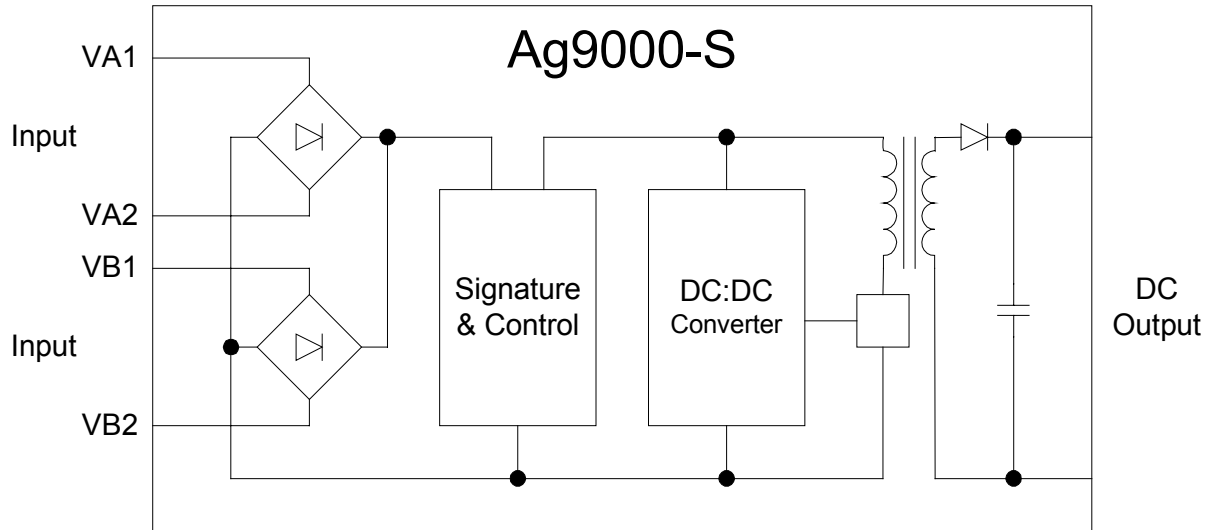


Figure 1: Block Diagram

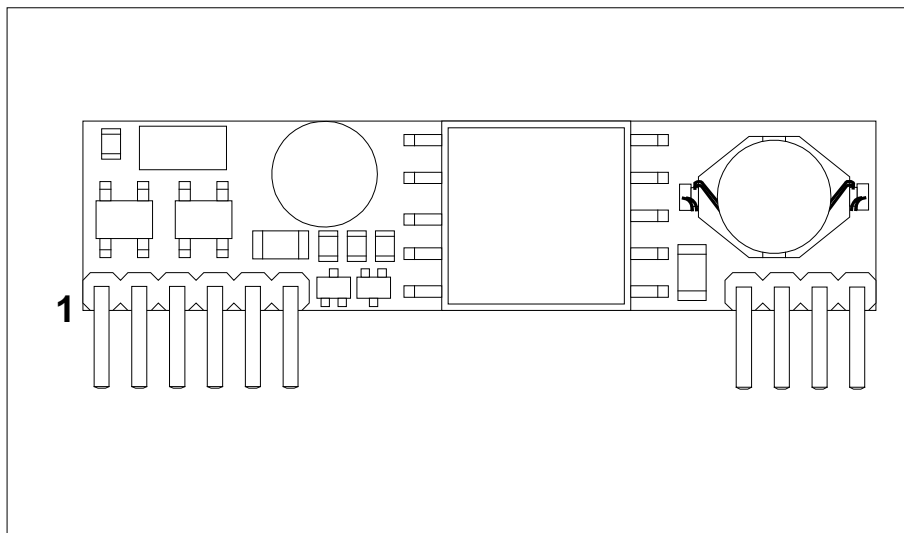


Figure 2: Ag9000-S Package Format

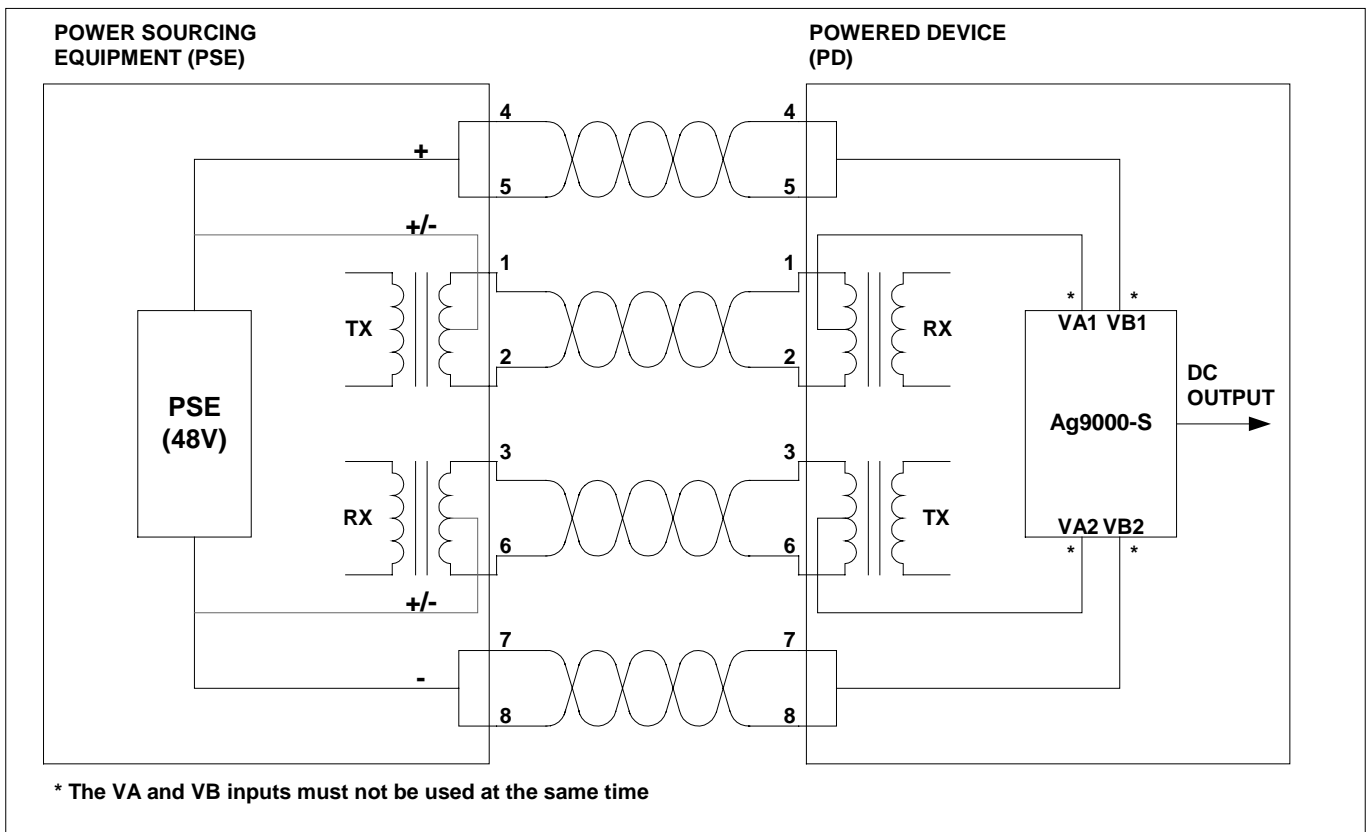
## 4. Pin Description

Pin #	Name	Description
1	VA1	<b>RX Input (1).</b> This input pin is used in conjunction with VA2 and connects to the centre tap of the transformer connected to pins 1 & 2 of the RJ45 connector (RX) - it is not polarity sensitive.
2	VA2	<b>TX Input (2).</b> This input pin is used in conjunction with VA1 and connects to the centre tap of the transformer connected to pins 3 & 6 of the RJ45 connector (TX) - it is not polarity sensitive.
3	VB1	<b>Direct Input (1).</b> This input pin is used in conjunction with VB2 and connects to pin 4 & 5 of the RJ45 connector - it is not polarity sensitive.
4	VB2	<b>Direct Input (2).</b> This input pin is used in conjunction with VB1 and connects to pin 7 & 8 of the RJ45 connector - it is not polarity sensitive.
5	CP1	<b>Class Programming (1).</b> Connect an external resistor to CP2 will change the current class of the module. With no resistor fitted the Ag9000 will default to Class 0.
6	CP2	<b>Class Programming (2).</b> Connect an external resistor to CP1 will change the current class of the module. With no resistor fitted the Ag9000 will default to Class 0.
7	GND	<b>Ground.</b> The ground return for the +VDC output.
8	+VDC	<b>DC Output.</b> This pin provides the regulated output from the DC/DC converter.
9	ADJ	<b>Output Adjust.</b> The output voltage can be adjusted from its nominal value, by connecting an external resistor from this pin to either the +VDC pin or the GND pin.
10	IC	<b>Internal Connection.</b> Do not connect to this pin.

## 5. Functional Description

### 5.1. Inputs

The Ag9000-S has two internal bridge rectifiers (see Figure 1: Block Diagram) connected to the VA1-VA2 and the VB1-VB2 inputs. This allows the Ag9000-S to be compatible with equipment that use the different power options, see Figure 3: Typical System Diagram. It is important that the PSE does not apply power to the VA and VB outputs at the same time (Refer to IEEE802.3af for more information).



**Figure 3: Typical System Diagram**

### 5.2. PD Signature

When the Ag9000-S is connected to the Cat 5e cable, it will automatically present a Powered Device (PD) signature to the Power Sourcing Equipment (PSE) or Midspan Equipment, when requested. The equipment will then recognise that a powered device is connected to that line and supply power.

### 5.3. Isolation

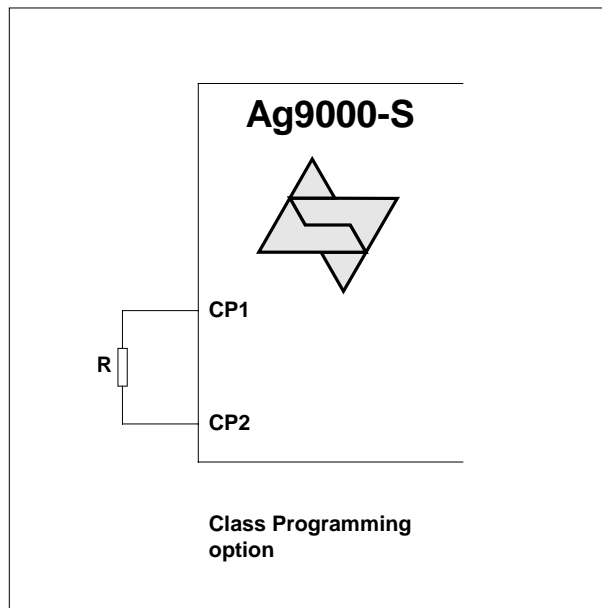
To meet the safety isolation requirements of IEEE802.3af section 33.4.1 a Powered Device (PD) must pass the electrical strength test of IEC 60950 sub clause 6.2. This calls for either a) 1500VAC test or b) 1500V impulse test. The Ag9000-S is specified to meet the 1500V impulse test.

## 5.4. Power Classification

This is optional from the PSE and is used for power management. The Ag9000-S allows the current class to be externally programmed by connecting a resistor between the CP1 and CP2 pins, see Figure 4: Class Programming Option. If no resistor is fitted the Ag9000-S will default to Class 0, a full list of programming resistor values are shown in Table 2: Class Programming.

CLASS	Programming Resistance (Ohms)	Min Power (W)	Max Power (W)
0	Do not fit	0.44	12.95
1	698	0.44	3.84
2	383	3.84	6.49
3	243	6.49	12.95
4	TBD	Reserved	Reserved

**Table 2: Class Programming**



**Figure 4: Class Programming Option**

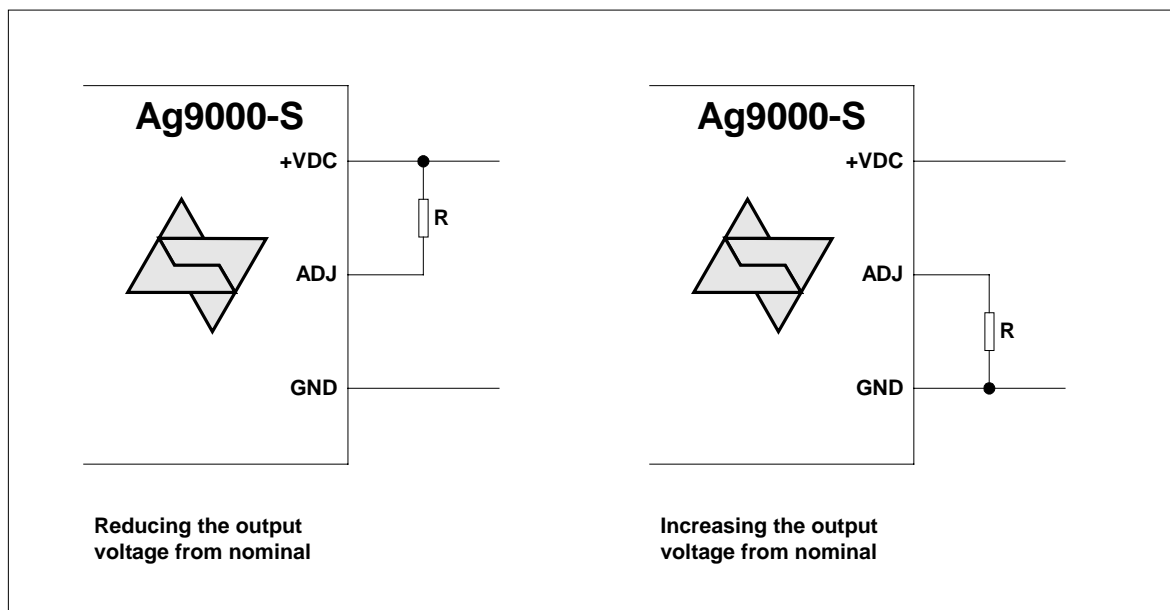
## 5.5. DC/DC Converter

The Ag9000-S's DC/DC converter provides a regulated low ripple and low noise output, that has built-in overload and short-circuit output protection - see Table 1: Ordering Information for voltage and power ratings.

## 5.6. Output Adjustment

The Ag9000-S has an ADJ pin, which allows the output voltage to be increased or decreased from its nominal value.

Figure 5: Output Adjustment shows how the ADJ pin is connected: -



**Figure 5: Output Adjustment**

<b>Reducing the output voltage, connect R between ADJ and +VDC</b>			
Value of R	Ag9033-S output	Ag9050-S output	Ag9120-S output
Open Circuit	3.30V	5.00V	12.00V
100k Ohms	3.25V	4.75V	10.00V
0 Ohms	3.10V	4.50V	9.00V
<b>Increasing the output voltage, connect R between ADJ and GND</b>			
Value of R	Ag9033-S output	Ag9050-S output	Ag9120-S output
Open Circuit	3.30V	5.00V	12.00V
100k Ohms	3.40V	5.25V	12.75V
0 Ohms	4.70V	5.50V	13.15V

**Table 3: Output Adjustment Resistor (R) Value**

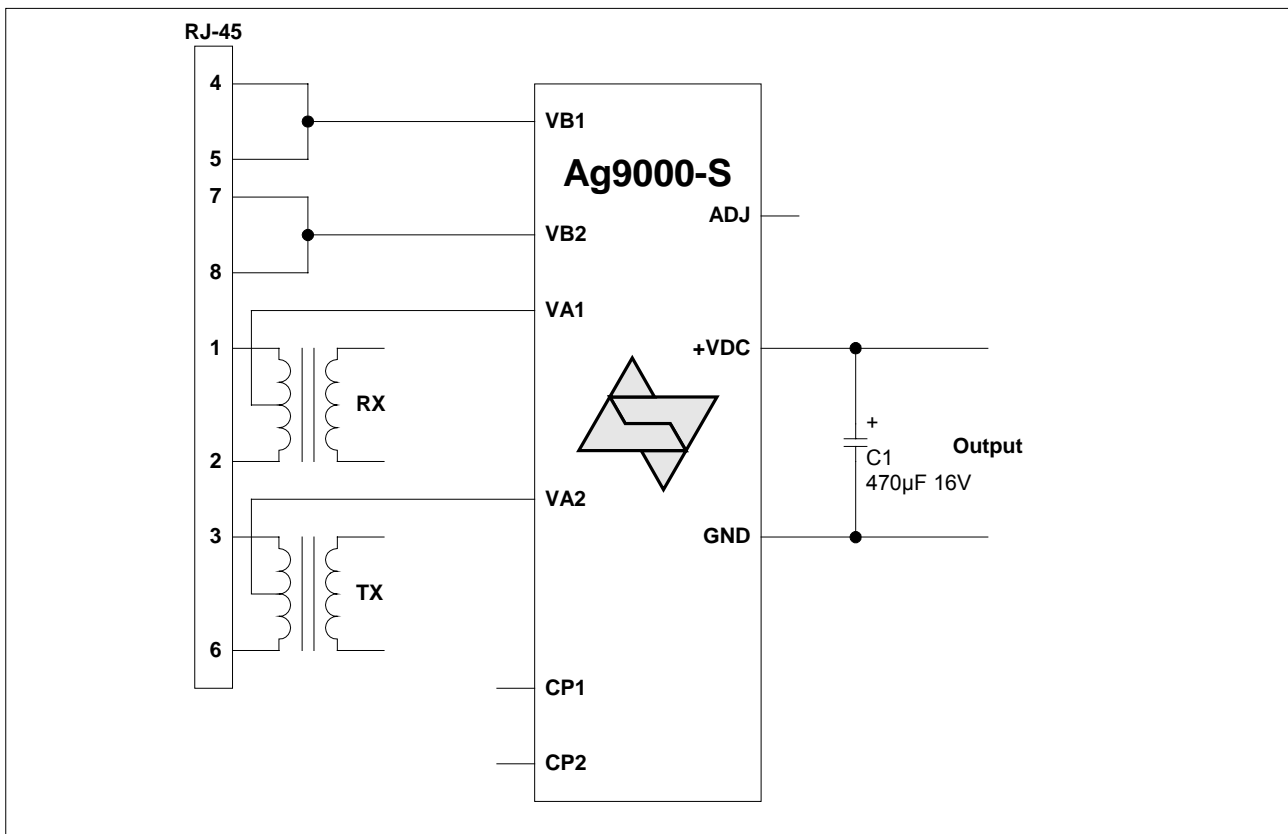
## 5.7. Typical Connections

The Ag9000-S only requires one external component as shown in Figure 6: Typical Connection Diagram, a minimum of 470µF is recommended.

The value of C1 will be related to the maximum load step change that the output needs to drive. For example, in an application where the output needs to cope with a 1.8 Amp load step change, a minimum of 1000µF should be used. This can be a standard low cost electrolytic and does not need to be a low ESR type.

Figure 6 shows a 16V capacitor that would cover all product variants up to and including the Ag9120-S, see Table 1: Ordering Information.

The Class programming and the Output Adjust inputs are optional and are provided to give great flexibility to the Ag9000-S product range. Further information on using these inputs can be found in sections 5.4. Power Classification and 5.6. Output Adjustment.



**Figure 6: Typical Connection Diagram**

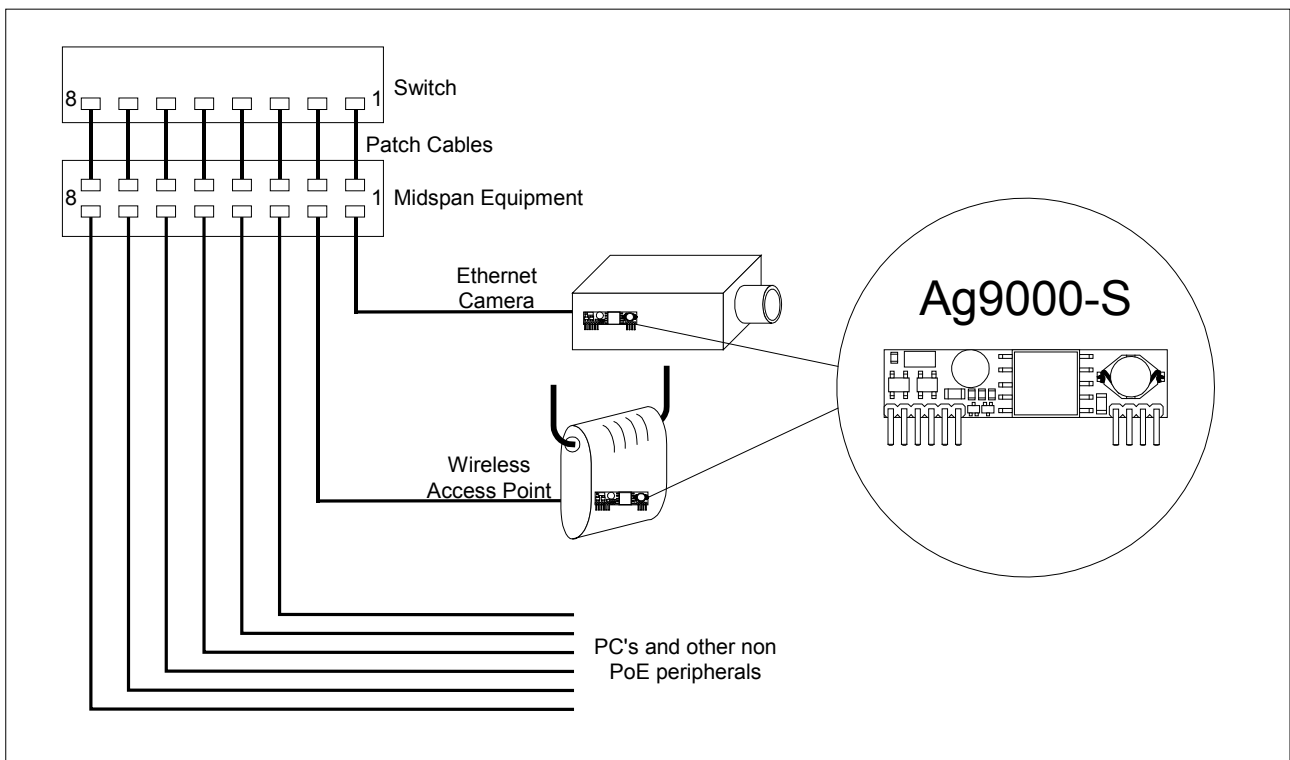


## 6. Typical Application

The Ag9000-S can be used in numerous applications. In the example shown in Figure 7: Typical Application, the data outputs from the switch are connected to the inputs of a midspan. The midspan will then add power (to the data) on each output that supports Power over Ethernet (PoE).

In this example port 1 is connected to an ethernet camera and port 2 is connected to a wireless access point, both of these devices have a built-in Ag9000-S. When the midspan is switched on (or when the device is connected), the midspan will check each output for a PoE signature. On ports 1 and 2 the Ag9000-S will identify themselves as PoE enabled devices and the midspan will supply both data and power to these peripherals.

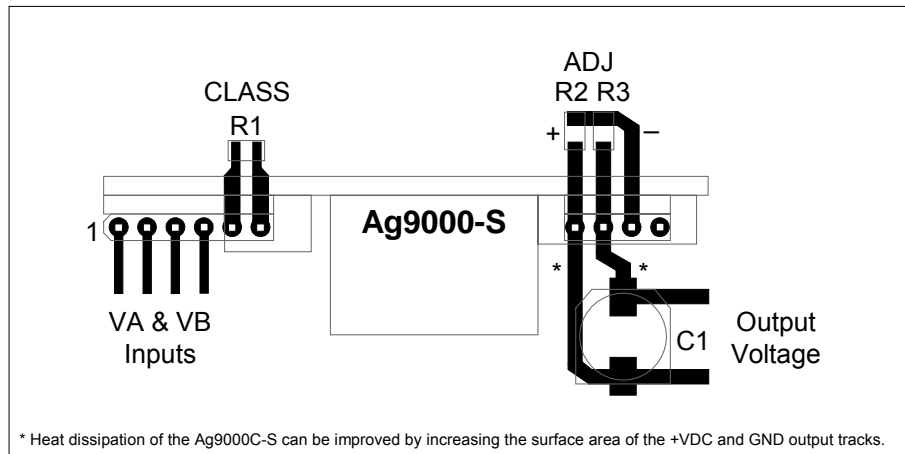
The other ports (shown in this example) will not have a PoE signature and the midspan will only pass the data through to these peripherals. The midspan will continuously monitor each output to see if a PoE enabled device has been added or removed.



**Figure 7: Typical Application**

## 7. Typical Recommendations

Figure 8: Typical Layout gives an example of the tracking needed for the Ag9000-S. R1, R2 and R3 are optional components, but C1 needs to be positioned close to the output pins of the Ag9000-S as possible to minimise the current loop. The thermal performance of the Ag9000-S can be improved by increasing the surface area of the output tracks (+VDC and GND) this is not applicable if the Ag9000-S is in a socket.



**Figure 8: Typical Layout**

## 8. Operating Temperature Range

Because the Ag9000-S is a power component, it will generate heat, so it is important that this be taken into consideration at the design stage.

The heart of the Ag9000-S is a DC/DC converter, which like any other power supply will generate heat. The amount of heat generated by the module will depend on the load it is required to drive and the input voltage supplied by the PSE. The information shown within this section of datasheet is referenced to a nominal 48Vdc input voltage supplied by the PSE.

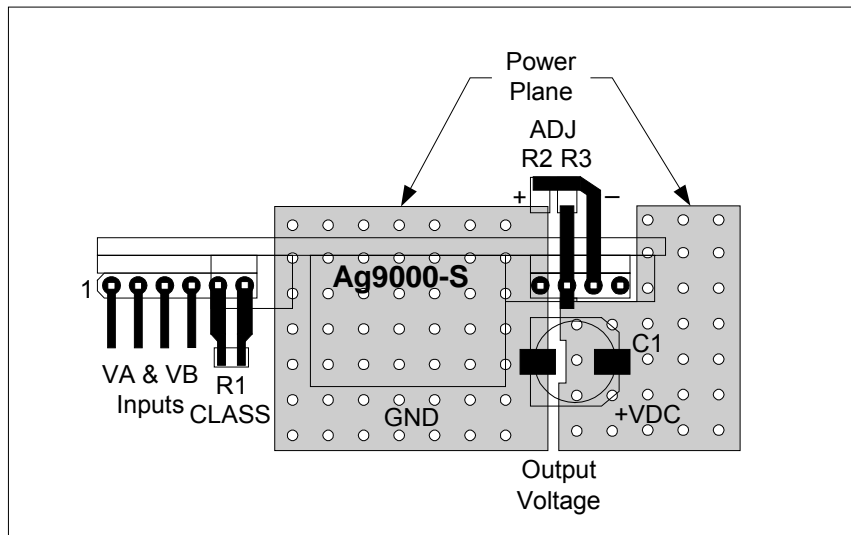
The Ag9000-S has a maximum ambient operating temperature of 70 °C see Figure 10, Figure 11 & Figure 12. These results are in still air without any heatsinking, the performance of the Ag9000-S can be improved by forcing the airflow over the part or by using a heatsink (see the Ag9000-S application note on heatsinking for more information).

The output stage of the Ag9000-S has a built-in thermal protection circuit, to prevent the module from being damaged if operated beyond its power / temperature specification.

Because each application is different it is impossible to give fixed and absolute thermal recommendations. However it is important that any enclosure used has sufficient ventilation for the Ag9000-S and a direct airflow if possible.

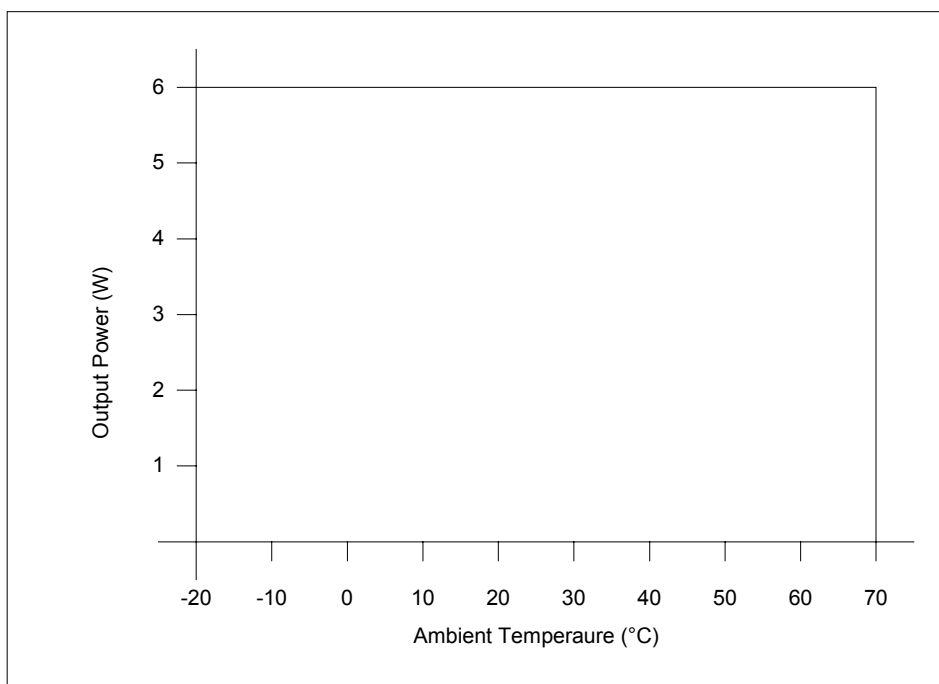
One simple method for drawing some of the heat away from the Ag9000-S is shown in Figure 9. Power planes connected to the +VDC and GND pins of the Ag9000-S can be used to draw heat away from the DC/DC converter via the output pins.

These power planes must be on the outer layers of the PCB and the Ag9000-S must not be fitted into a socket.

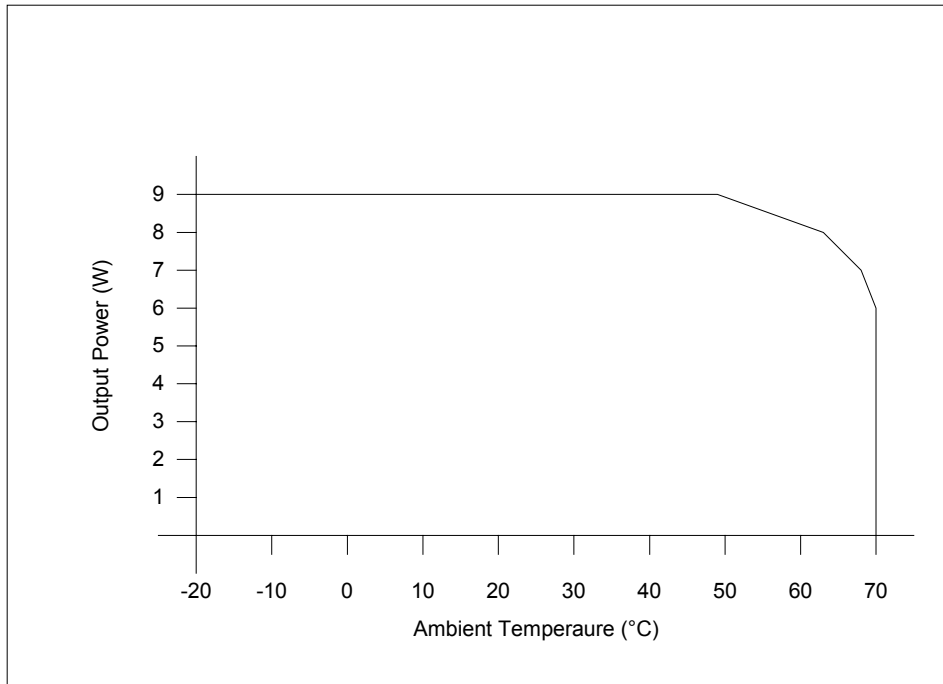


**Figure 9: Power Plane Heatsink for Ag9000-S**

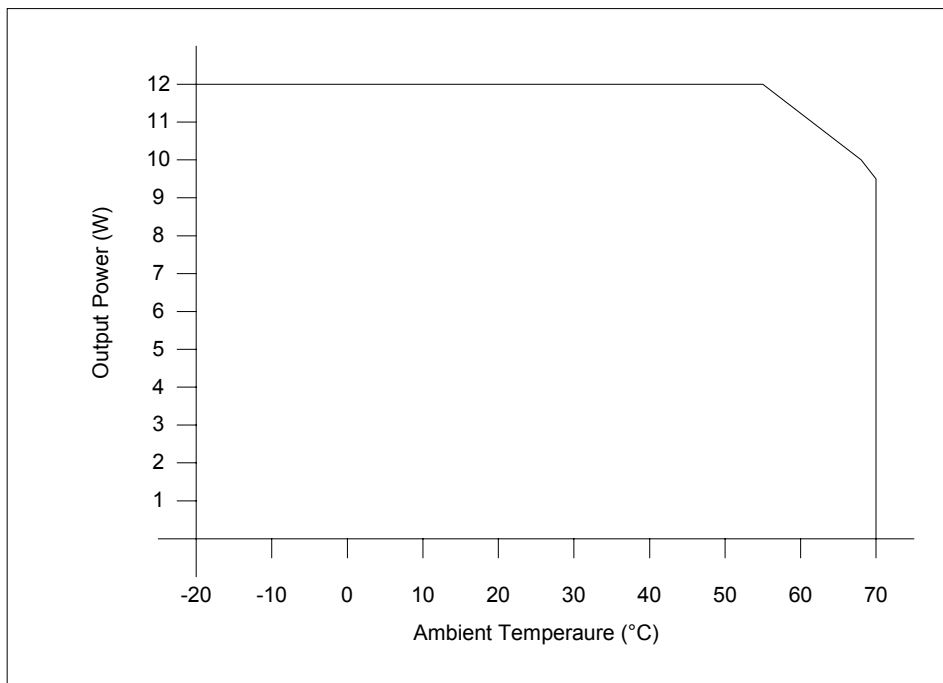
Figure 10, Figure 11 & Figure 12 show the maximum ambient temperature under different load conditions. These figure have been recorded in a sealed enclosure (in still air) using a heater element to elevate the ambient temperature (within the enclosure).



**Figure 10: Ag9033-S Operating Profile**



**Figure 11: Ag9050-S Operating Profile**



**Figure 12: Ag9120-S Operating Profile**

## 9. Electrical Characteristics

### 9.1. Absolute Maximum Ratings\*

	Parameter	Symbol	Min	Max	Units
1	DC Supply Voltage	$V_{CC}$	-0.3	60	V
2	DC Supply Voltage Surge for 1ms	$V_{SURGE}$	-0.6	80	V
3	Storage Temperature	$T_S$	-40	+100	$^{\circ}C$

\*Exceeding the above ratings may cause permanent damage to the product. Functional operation under these conditions is not implied. Maximum ratings assume free airflow.

### 9.2. Recommended Operating Conditions

	Parameter	Symbol	Min	Typ	Max	Units
1	Input Supply Voltage ‡	$V_{IN}$	36	48	60	V
2	Under Voltage Lockout	$V_{LOCK}$	30		36	V
3	Operating Temperature	$T_{OP}$	-20	25	70†	$T_a / ^{\circ}C$

†See Section 8. Operating Temperature Range

‡With minimum load

### 9.3. DC Electrical Characteristics\*

	DC Characteristic	Sym	Min	Typ*	Max	Units	Test Comments
1	Nominal Output Voltage	+VDC		3.3 5 12		V V V	Ag9033-S Ag9050-S Ag9120-S
2	Output Current ( $V_{IN} = 48V$ )	PWR			1.8 1.8 1	A A A	Ag9033-S Ag9050-S Ag9120-S
3	Line Regulation	$V_{LINE}$		0.1		%	@ 50% Load
4	Load Regulation	$V_{LOAD}$		0.5		%	@ $V_{IN}=48V$
5	Output Ripple and Noise	$V_{RN}$		100		mVp-p	@ Max load †
6	Minimum Load	$R_{LOAD}$	100			mA	for specified regulation ‡
7	Short-Circuit Duration	$T_{SC}$			$\infty$	sec	Continuous @ $50^{\circ}C$ , $V_{IN}=48V$
8	Efficiency	EFF		75		%	Ag9050-S @ 50% Load
9	Isolation Voltage (I/O)	$V_{ISO}$			1500	$V_{DC}$	
10	Temperature Coefficient	TC		0.02		%	Per $^{\circ}C$

\*Typical figures are at 25°C with a nominal 48V supply and are for design aid only. Not Guaranteed

†The output ripple and noise can be reduced with an external filter, see application note.

‡Can be used with no load at reduced voltage regulation.

## 10. Package

### 10.1. Ag9000-S

