

CERAMIC SURFACE MOUNT LOW PROFILE QUARTZ CRYSTALS

ABMM2

ABMM2



6.0 x 3.6 x 1.2 mm



RoHS
Compliant

FEATURES:

- Suitable for solder reflow
- Low in height - suitable for thin equipment
- ATstrip cut offers a tight tolerance & stability

APPLICATIONS:

- Computers, Modems, Microprocessors
- Communication, Test equipment
- PCMCIA

STANDARD SPECIFICATIONS:

PARAMETERS

ABRACON P/N	ABMM2 Series
Frequency Range	8.00 MHz - 110.00 MHz
Operation Mode	8.00 MHz ~ 50.00 MHz (Fundamental) 30.01 MHz ~ 100.00 MHz (3rd Overtone) 90.00 MHz ~ 110.00 MHz (5th Overtone)
Operating Temperature	-10°C to +60°C (See Options)
Storage Temperature	-40°C to +85°C
Frequency Tolerance @ 25°C	± 20 ppm max. (See Options)
Frequency Stability over Operating Temp. (Ref to +25°C)	± 20 ppm max. (See Table 1)
Equivalent Series Resistance	See Table 1
Shunt Capacitance C ₀	7pF max.
Load Capacitance C _L	18pF (see options)
Drive Level	500µW max., 100µW correlation
Aging at 25°C First Year	± 2ppm max.
Insulation Resistance	500MΩ min. @ 100Vdc ± 15V

TABLE 1

Frequency (MHz)	ESR (Ω)
8.0 - 9.9 (Fund)	72
10.0 - 50.0 (Fund)	50
30 - 100 (3rd OT)	60
90 - 110 (5th O/T)	80

OPTIONS & PART IDENTIFICATION:

(Left blank if standard)

ABMM2 - Frequency - - R - - - -

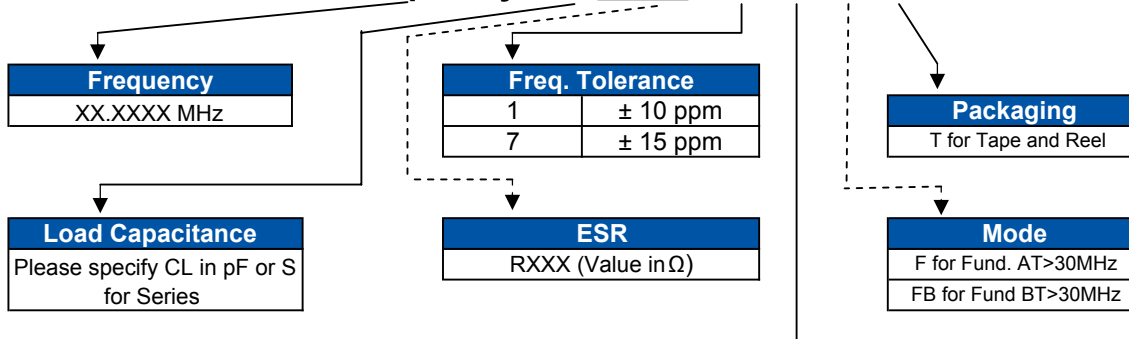

Frequency -vs.- Temperature				
Temp. Range °C	±4 ppm max.	±5 ppm max.	±10 ppm max.	±20 ppm max.
0°C to +50°C	A1	A2	A3	A4
-10°C to +50°C	B1	B2	B3	B4
-10°C to +60°C		C2	C1	Standard
-20°C to +70°C			E1	E2
-40°C to +85°C				D1

ABRACON IS
ISO 9001 / QS 9000
CERTIFIED



ABRACON
CORPORATION

30332 Esperanza, Rancho Santa Margarita, California 92688
tel 949-546-8000 | fax 949-546-8001 | www.abracon.com

Revised: 05.01.07

CERAMIC SURFACE MOUNT LOW PROFILE QUARTZ CRYSTALS

ABMM2



RoHS
Compliant



6.0 x 3.6 x 1.2 mm

OUTLINE DRAWING:

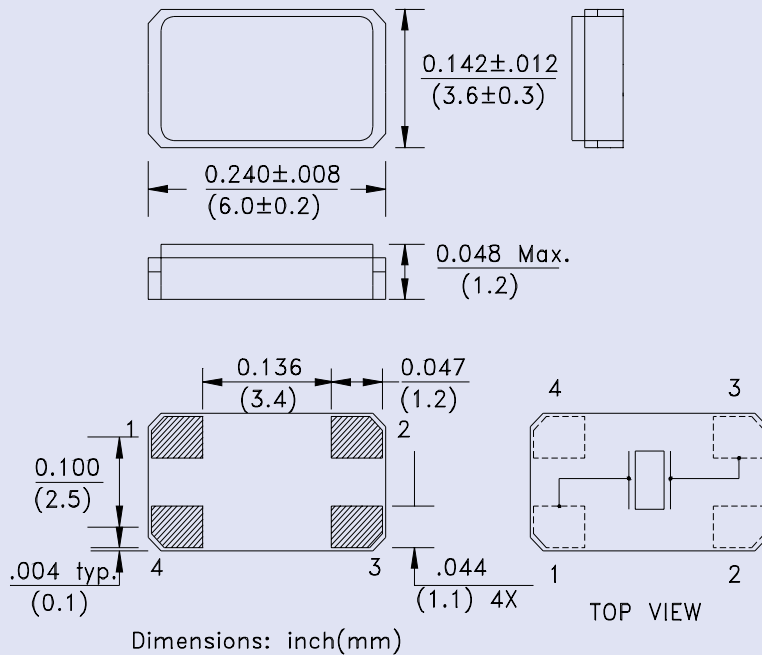

Recommended land pattern

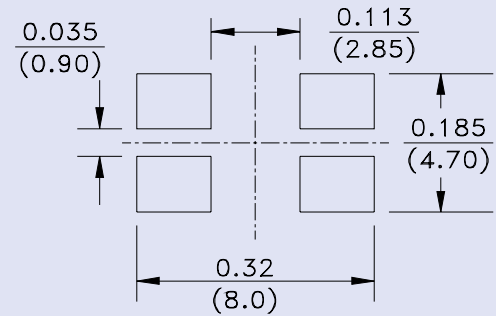

Note 1: A chamfer of 0.3mm may appear on pad 4.
Note 2: A rounded pad may appear on pad 1.

TAPE & REEL:

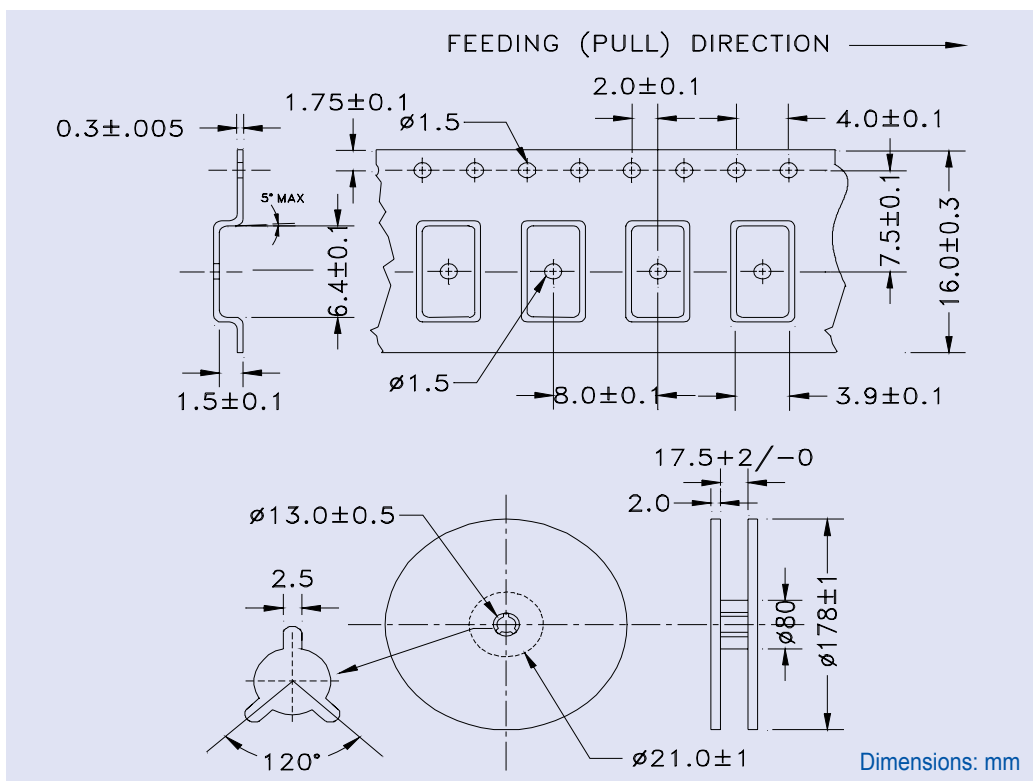

ABRACON IS
ISO 9001 / QS 9000
CERTIFIED



Revised: 05.01.07
30332 Esperanza, Rancho Santa Margarita, California 92688
tel 949-546-8000 | fax 949-546-8001 | www.abracon.com