

2650A/B Broadband Photodiode



Description

The 2650A/B provides the proven high performance of our photodiode technology in a very practical, cost-effective package. The 2650-series features high linearity and low capacitance over a 1 GHz bandwidth. These broadband photodiodes are housed in a small, environmentally rugged coaxial package.

The 2650A/B broadband photodetector is designed to provide the performance and flexibility needed to meet the expanding applications of two-way communications networks. This photodiode is used today in forward- and return-path applications, including AM-VSB CATV, QAM 64/256, PON, FTTC, and FTTH receivers.

Features

- Low capacitance, ≤ 0.6 pF
- 1 GHz flat response, ± 0.5 dB
- High responsivity:
 - ≥ 0.85 at 1310 nm
 - ≥ 0.95 at 1550 nm

Applications

- Forward-path and return-path broadband video transport
- EDFA/network monitors

Absolute Maximum Ratings

Stresses in excess of the absolute maximum ratings can cause permanent damage to the device. These are absolute stress ratings only. Functional operation of the device is not implied at these or any other conditions in excess of those given in the operational sections of the data sheet. Exposure to absolute maximum ratings for extended periods can adversely affect device reliability.

Parameter	Symbol	Min	Max	Unit
Operating Temperature Range	TOP	-40	85	°C
Storage Temperature Range	Tstg	-40	85	°C
Input Power Saturation	PIN	—	10	mW
Reverse Voltage	VR	—	30	V
Forward Current	IF	—	10	mA
Power Dissipation	PDISS	—	<100	mW

Characteristics

Table 1. Electrical/Optical Characteristics

Parameter	Symbol	Min	Typ	Max	Unit
Optical Wavelength Range	λ	1100	—	1600	nm
Responsivity	—	—	>0.85 at 1310 nm, >0.95 at 1550 nm	—	mA/mW mA/mW
Frequency Range	F	1	—	1000	MHz
Frequency Response	—	—	± 0.5	—	dB
Distortion Products: ¹					
Composite Second Order	CSO	—	≤ -75	—	dBc
Composite Triple Beat	CTB	—	≤ -85	—	dBc
Back Reflection	RL	—	≤ -40	—	dB
Dark Current	ID	—	≤ 5 at 25 °C	—	nA
Capacitance	—	—	≤ 0.6	—	pF
Bandwidth	BW	—	1.0	—	GHz

1. Two laser test at 1310 nm. Each laser has 40% modulation index. Total received power is 0 dBm. Distortion products measured at 80 MHz, 450 MHz, 600 MHz, 850 MHz, and 1000 MHz.

Outline Diagram

2650A/B Photodiode with Electrical Schematic (Dimensions are in inches and (millimeters.))

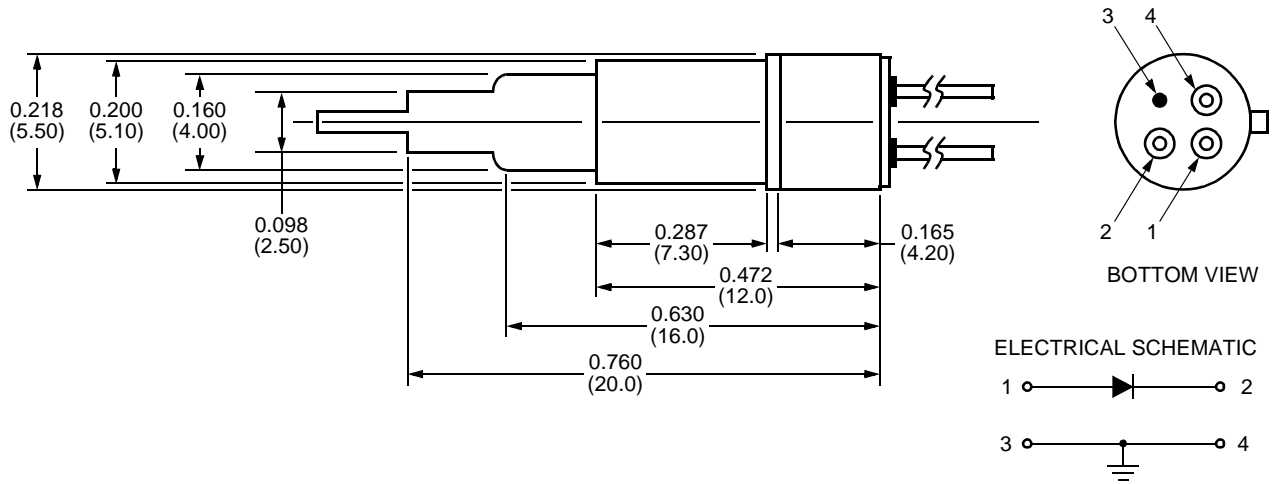

2650A/B Photodiode Bracket (Dimensions are in millimeters.)

1-1185 (F)

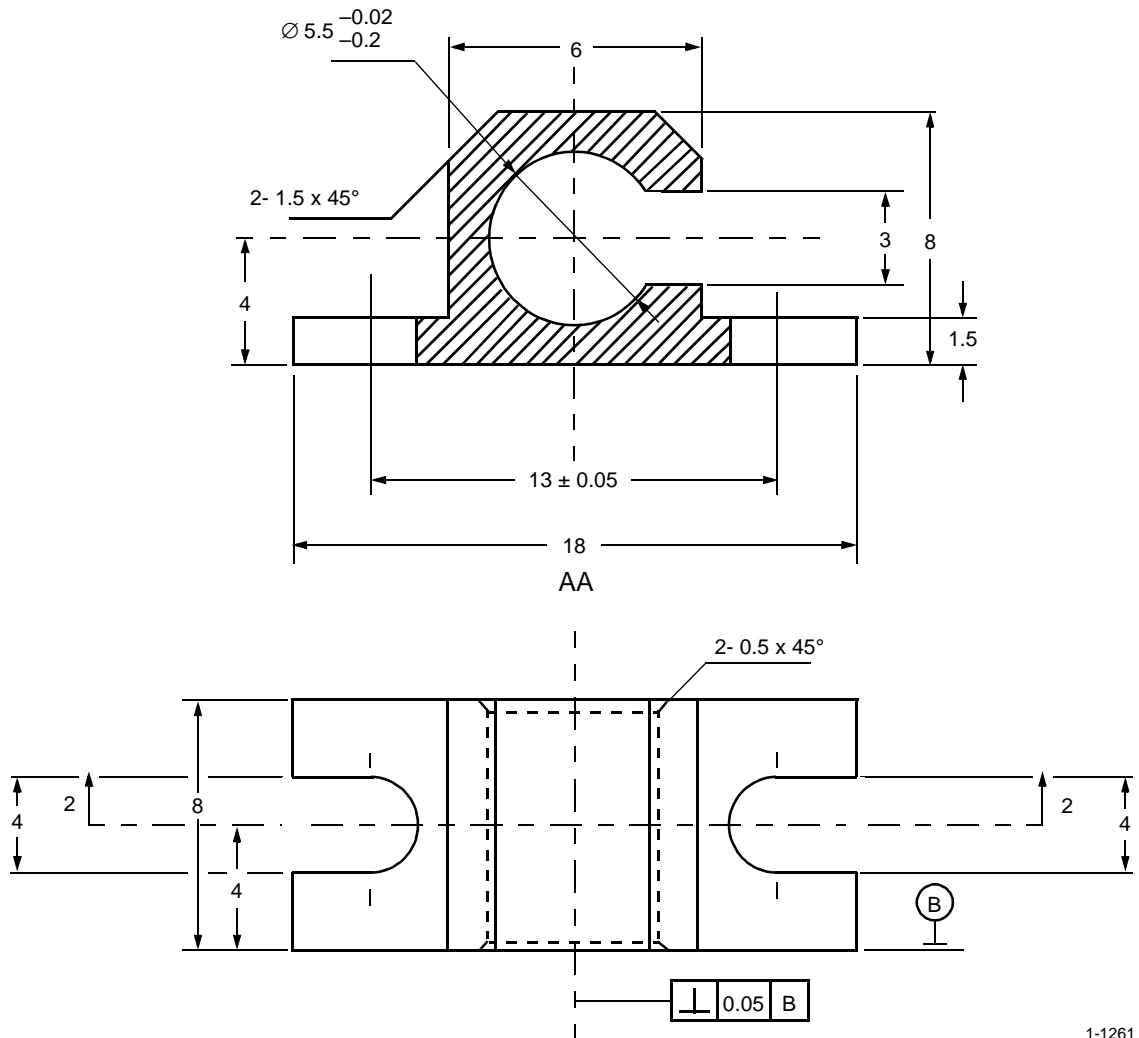

1-1261 (F)

Ordering Information

Table 2. Ordering Information¹

Device Code	Description	Fiber ²	Connector ²	Comcode
2650A	Broadband Photodiode without Mounting Bracket	Single-mode, 900 μ m	—	108866500
2650B	Broadband Photodiode with Mounting Bracket	Single-mode, 900 μ m	—	108866567

1. Other options available. For additional ordering information, please contact an account manager at OPTO West, Agere Systems Inc., 1-800-362-3891 (for sales staff, please press option 2).

2. Please specify fiber length and connector type when ordering.

For additional information, contact your Agere Systems Account Manager or the following:

INTERNET: <http://www.agere.com>

E-MAIL: docmaster@micro.lucent.com

N. AMERICA: Agere Systems Inc., 555 Union Boulevard, Room 30L-15P-BA, Allentown, PA 18109-3286

1-800-372-2447, FAX 610-712-4106 (In CANADA: **1-800-553-2448**, FAX 610-712-4106)

ASIA PACIFIC: Agere Systems Singapore Pte. Ltd., 77 Science Park Drive, #03-18 Cintech III, Singapore 118256

Tel. (65) 778 8833, FAX (65) 777 7495

CHINA: Agere Systems (Shanghai) Co., Ltd., 33/F Jin Mao Tower, 88 Century Boulevard Pudong, Shanghai 200121 PRC

Tel. (86) 21 50471212, FAX (86) 21 50472266

JAPAN: Agere Systems Japan Ltd., 7-18, Higashi-Gotanda 2-chome, Shinagawa-ku, Tokyo 141, Japan

Tel. (81) 3 5421 1600, FAX (81) 3 5421 1700

EUROPE: Data Requests: DATALINE: **Tel. (44) 7000 582 368**, FAX (44) 1189 328 148

Technical Inquiries: OPTOELECTRONICS MARKETING: **(44) 1344 865 900** (Ascot UK)

Agere Systems Inc. reserves the right to make changes to the product(s) or information contained herein without notice. No liability is assumed as a result of their use or application.