

INTEGRATED CONNECTOR MODULES

0873-2X8R-66 Power over Ethernet MagJack® with LEDs 2 x 8

ELECTRICAL CHARACTERISTICS @ 25°C

URNS RATIO

TP1	1CT : 1CT ±2%
TP2	1CT : 1CT ±2%
TP3	1CT : 1CT ±2%
TP4	1CT : 1CT ±2%

OCL @ 100kHz/100mVRMS 8mA DC BIAS

350 μH MIN.

INS. LOSS

0.1MHz TO 1MHz	-1.1 dB MAX
1MHz TO 65MHz	-0.5 dB MAX
65MHz TO 100MHz	-0.8 dB MAX
100MHz TO 125MHz	-1.2 dB MAX

RET. LOSS (MIN)

0.5MHz-40MHz	-18 dB
40MHz-100MHz	-12+20LOG(F/80MHz) dB

CM TO CM REJ

100kHz - 100MHz	-30 dB MIN
-----------------	------------

CM TO DM REJ

100kHz - 100MHz	-35 dB MIN
-----------------	------------

HIPOT (Isolation Voltage)

2250 VDC

BALANCED DC LINE CURRENT

350 mA MAX. @ 57 VDC CONTINUOUS
500 mA MAX. @ 57 VDC for 200 MILLISECONDS

LED

VF (FORWARD VOLTAGE)	IF=20mA	GREEN	2.2V TYP.
		ORANGE	2.0V TYP.
λD (DOMINANT WAVELENGTH)	IF=20mA	GREEN	565nm TYP.
		ORANGE	610nm TYP.

BI-COLOR LED POLARITY		
PIN	GREEN	ORANGE
13	-	+
14	+	-

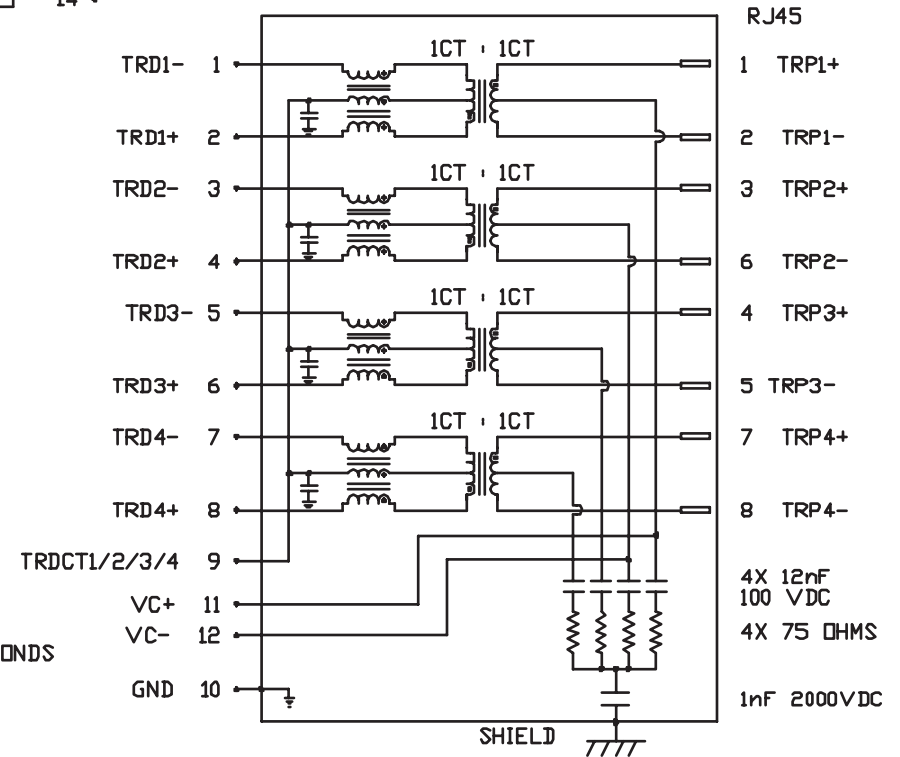
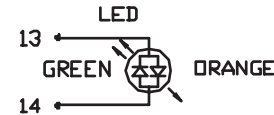

INTEGRATED CONNECTOR MODULES

0873-2X8R-66 Power over Ethernet MagJack® with LEDs 2 x 8

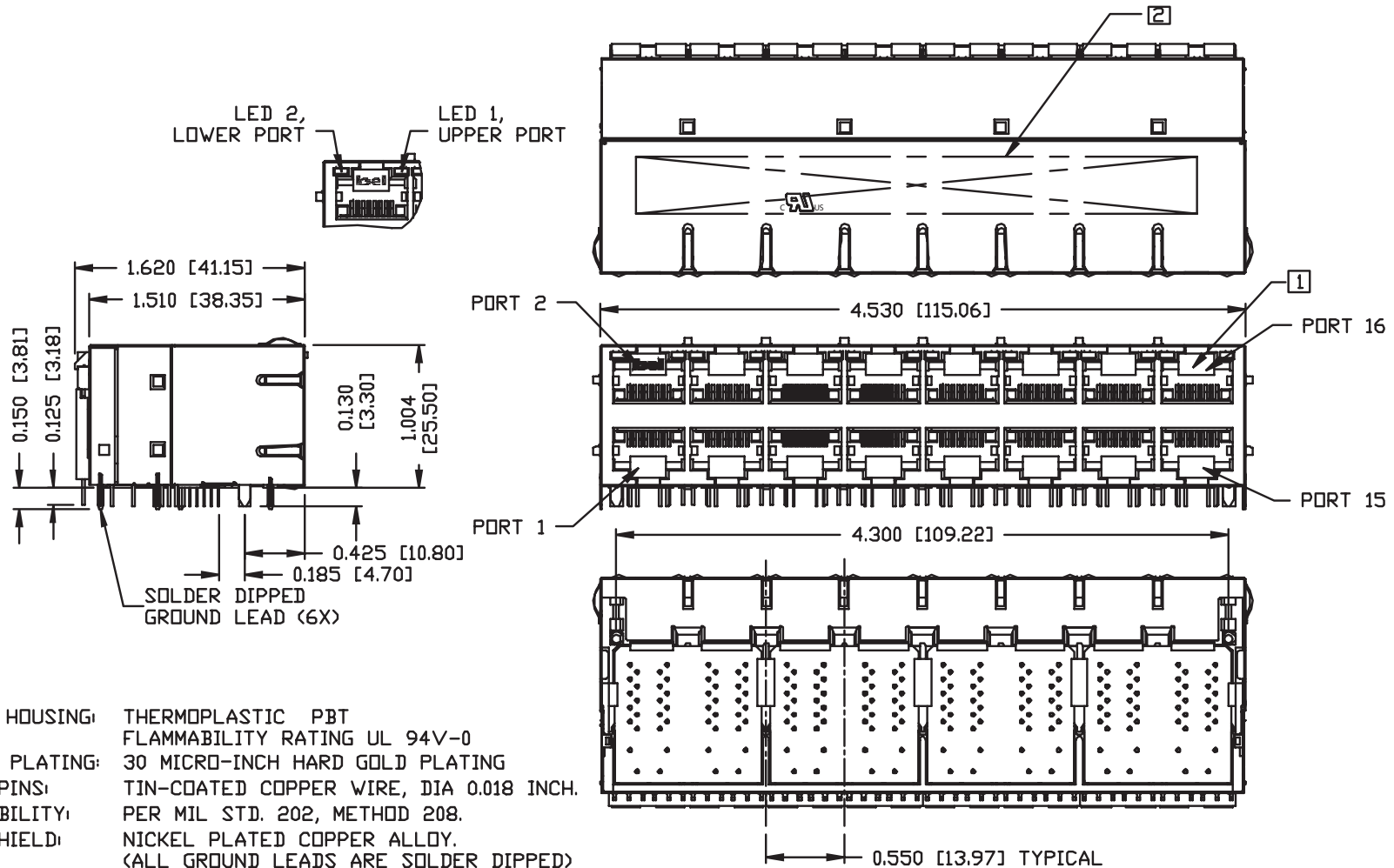

NOTES

- PLASTIC HOUSING: THERMOPLASTIC PBT
FLAMMABILITY RATING UL 94V-0
- CONTACT PLATING: 30 MICRO-INCH HARD GOLD PLATING
- OUTPUT PINS: TIN-COATED COPPER WIRE, DIA 0.018 INCH.
- SOLDERABILITY: PER MIL STD. 202, METHOD 208.
- METAL SHIELD: NICKEL PLATED COPPER ALLOY.
(ALL GROUND LEADS ARE SOLDER DIPPED)

- [1] JACK CAVITY CONFORMS TO FCC RULES AND REGULATIONS, PART 68 SUBPART F.
 - [2] MARK PART WITH MFG LOGO, MFG NAME, PART NUMBER, AND DATE CODE.
- UL RECOGNIZED - FILE #E196366 AND E169987.

INTEGRATED CONNECTOR MODULES

0873-2X8R-66 Power over Ethernet MagJack® with LEDs 2 x 8

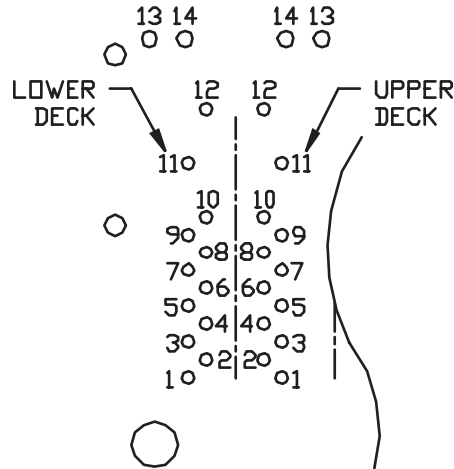

PIN-OUT INFORMATION
(COMPONENT SIDE VIEW)

14	GRN (+)/ORG (-)
13	GRN (-)/ORG (+)
12	VC-
11	VC+
10	GND
9	TRCT1/2/3/4
8	TRD 4+
7	TRD 4-
6	TRD 3+
5	TRD 3-
4	TRD 2+
3	TRD 2-
2	TRD 1+
1	TRD 1-

PORT ASSIGNMENT
(COMPONENT SIDE VIEW)

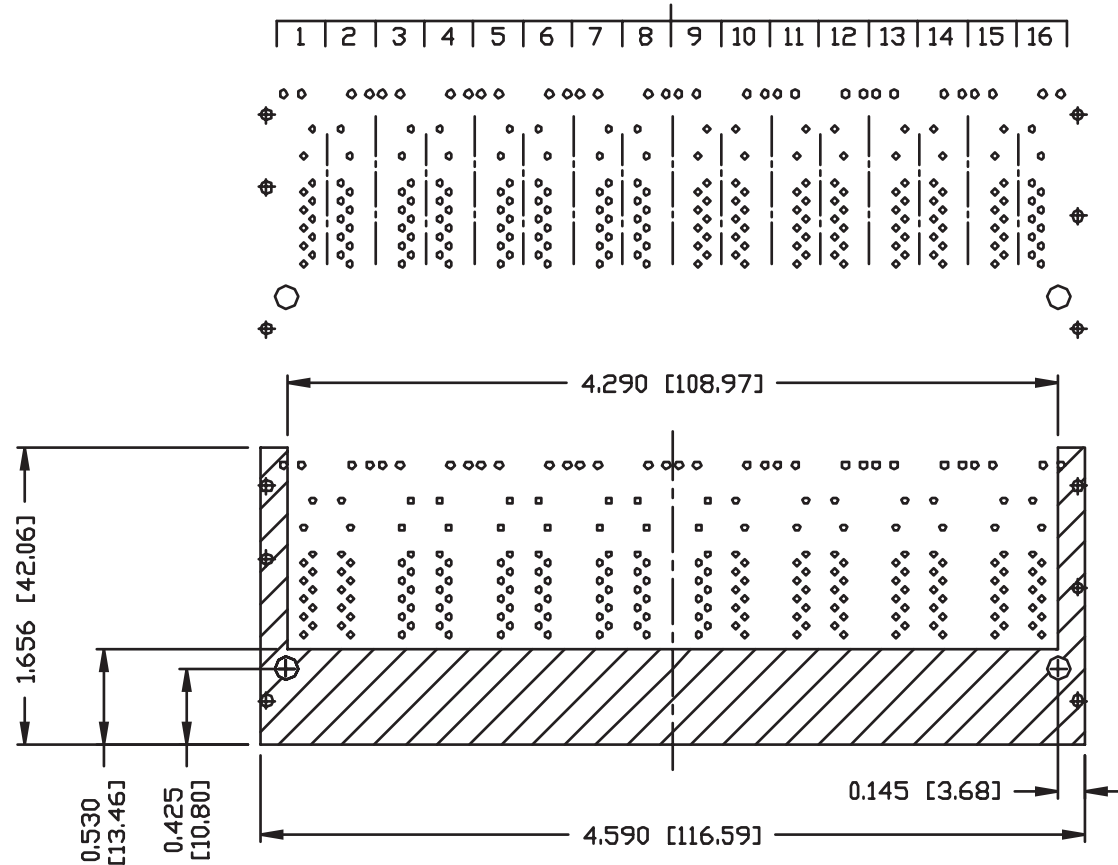

THE SHADED AREA ON THE CUSTOMER BOARD ARE RECOMMENDED TO BE CLEAR OFF ANY VIA HOLE OR COMPONENT PAD.

INTEGRATED CONNECTOR MODULES

0873-2X8R-66 Power over Ethernet MagJack® with LEDs 2 x 8

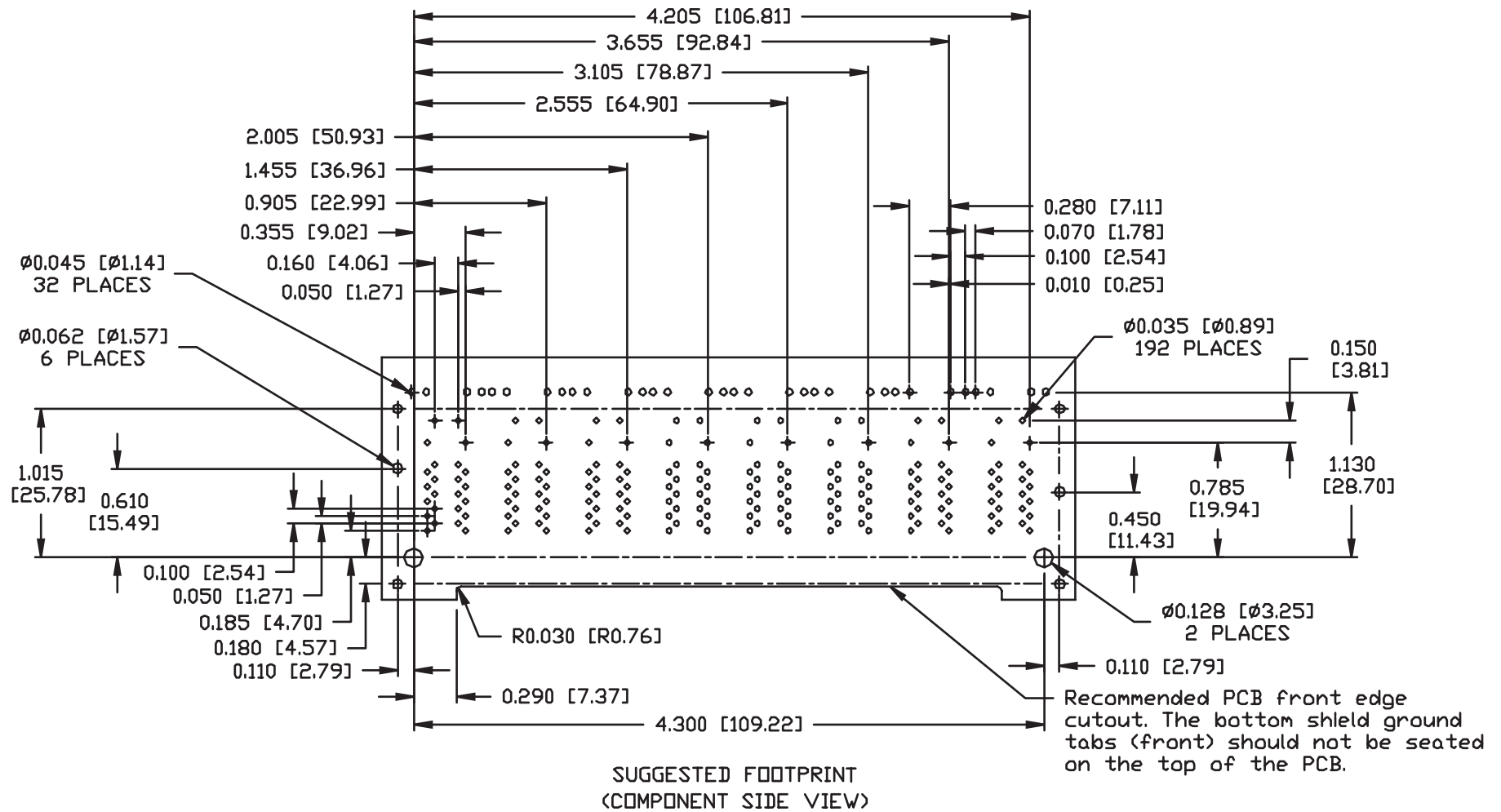

INTEGRATED CONNECTOR MODULES
0873-2X8R-66 Power over Ethernet MagJack® with LEDs 2 x 8

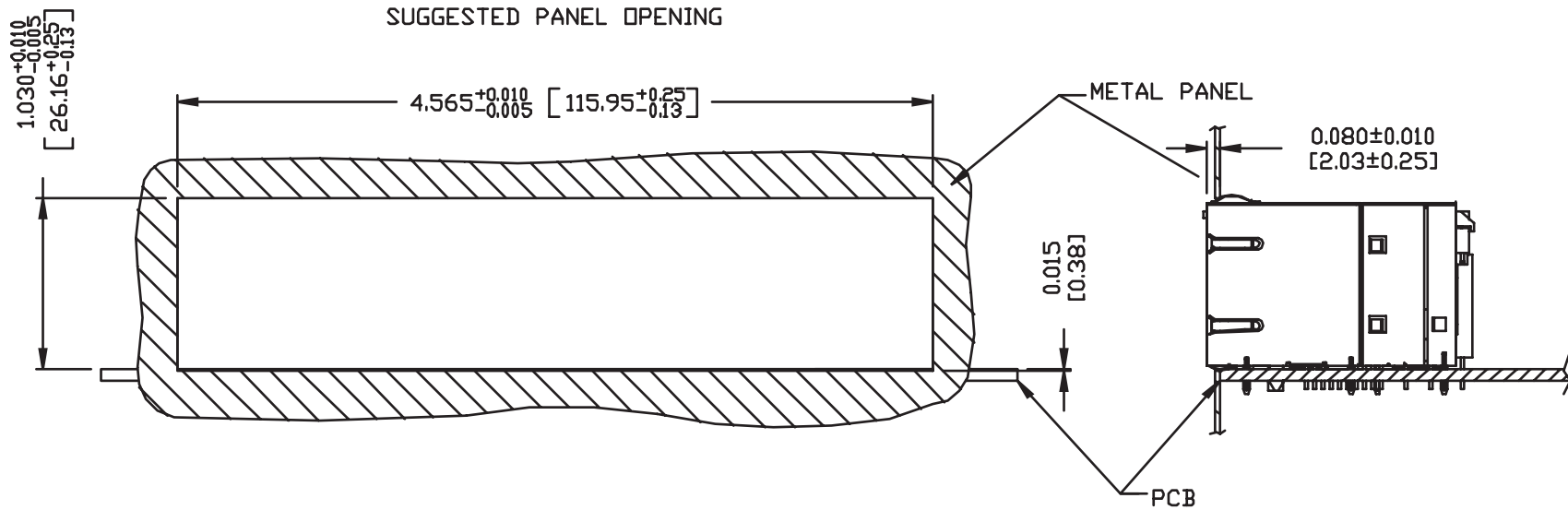

NOTE:

THE DISTANCE OF PANEL INSIDE SURFACE RELATIVE TO FRONT SURFACE OF PART IS ONLY A SUGGESTION. IN CASE THIS DISTANCE IS DIFFERENT, THE REQUIRED PANEL OPENING DIMENSIONS CHANGE ACCORDINGLY.

PACKING INFORMATION

PACKING TRAY : 0200-9999-D1 (TOP)

0200-9999-D9 (BOTTOM)

PACKING QUANTITY : 10 PCS FINISHED GOODS PER TRAY.

5 TRAYS (50 PCS FINISHED GOODS) PER CARTON BOX.

NOTE : CARDBOARDS ARE PLACED BETWEEN LAYERS OF PACKING TRAY INSIDE CARTON BOX.

(INCLUDE THE UPPERMOST AND LOWERMOST TRAY)