

1

PRODUCT OVERVIEW

S3C-SERIES MICROCONTROLLERS

Samsung's S3C8-series of 8-bit single-chip CMOS microcontrollers offers a fast and efficient CPU, a wide range of integrated peripherals, and various mask-programmable ROM sizes. Important CPU features include:

- Efficient register-oriented architecture
- Selectable CPU clock sources
- Idle and Stop power-down mode release by interrupt
- Built-in basic timer with watchdog function

A sophisticated interrupt structure recognizes up to eight interrupt levels. Each level can have one or more interrupt sources and vectors. Fast interrupt processing (within a minimum six CPU clocks) can be assigned to specific interrupt levels.

S3C820B MICROCONTROLLER

The S3C820B single-chip CMOS microcontroller is fabricated using a highly advanced CMOS process and is based on Samsung's newest CPU architecture.

The S3C820B is the microcontroller which has 64K-byte mask-programmable ROM and 192K-byte mask ROM for font data.

Using a proven modular design approach, Samsung engineers developed the S3C820B by integrating the following peripheral modules with the powerful SAM87 core:

- Four programmable I/O ports, excluding one BUZ pin, for a total of 32 pins.
- Eight bit-programmable pins for external interrupts.
- One 8-bit basic timer for oscillation stabilization and watchdog functions (system reset).
- One 8-bit timer/counter and one 16-bit timer/counter with selectable operating modes.
- Watch timer for real time.

The S3C820B is a versatile microcontroller for data bank or dictionary. It is currently available in a 128-pin QFP package.

FEATURES

CPU

- SAM87 CPU core

Memory

- 64K-byte internal program memory (ROM)
- 192K-byte internal memory (ROM) for font data
- 272-byte internal register file (Excluding LCD RAM)
- 6144-byte data RAM

Instruction Set

- 78 instructions
- IDLE and STOP instructions added for power-down modes

Instruction Execution Time

- 1.5 μ s at 4 MHz fx (minimum)
- 183 μ s at 32,768 Hz fxt

Interrupts

- Five interrupt levels and 15 interrupt sources
- 15 vectors (15 sources have a dedicated vector address)
- Fast interrupt processing feature (for one selected interrupt level)

I/O Ports

- Four 8-bit I/O ports (P0–P3) for a total of 32-bit programmable pins
- Eight input pins for external interrupts
- One output only pin for BUZ

Watch Timer

- Interval time: 3.91 ms, 1s at 32,768 Hz
- Four frequency outputs to BUZ pin and BUZ pin
- Clock source generation for LCD

LCD Controller/Driver

- 65 segments and 18 common terminals
- Internal resistor circuit for LCD bias
- Voltage doubler
- All dot can be switched on/off

Timers and Timer/Counters

- One programmable 8-bit basic timer (BT) for oscillation stabilization control or watchdog timer (software reset) function
- One 8-bit timer/counter (Timer 0) with three operating modes; Interval, Capture and PWM
- One 16-bit timer/counter (Timer 1) with two 8-bit timer/counter modes; Interval

Power-Down Modes

- Idle mode (CPU clock stops)
- Stop mode (main oscillation and CPU clock stops)

Operating Temperature Range

- -40°C to $+85^{\circ}\text{C}$

Operating Voltage Range

- 2.2 V to 4.5 V at 1 MHz fx
- 2.7 V to 4.5 V at 4 MHz fx

Package Type

- 128-pin QFP

BLOCK DIAGRAM

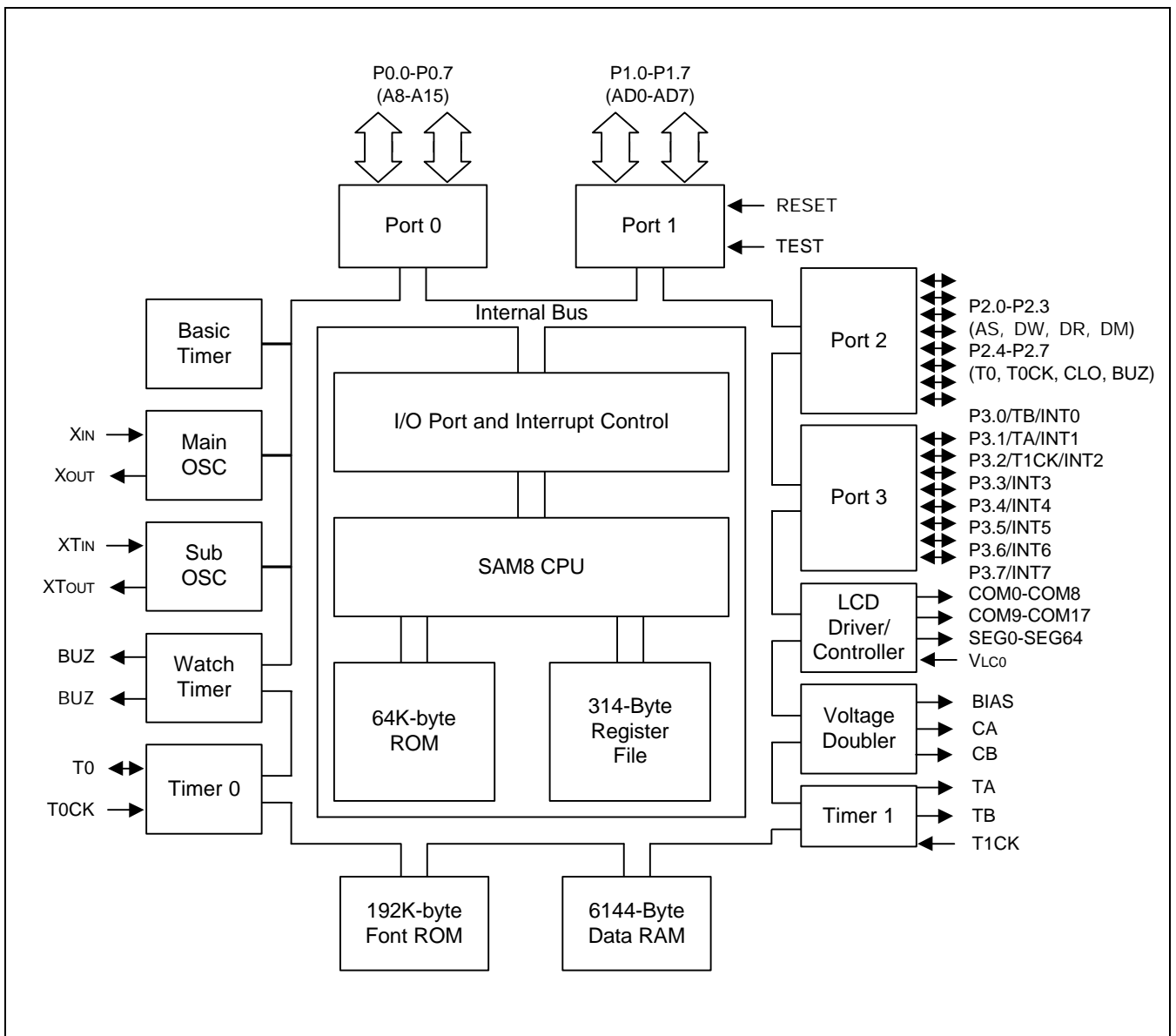

Figure 1-1. Block Diagram

PIN ASSIGNMENTS

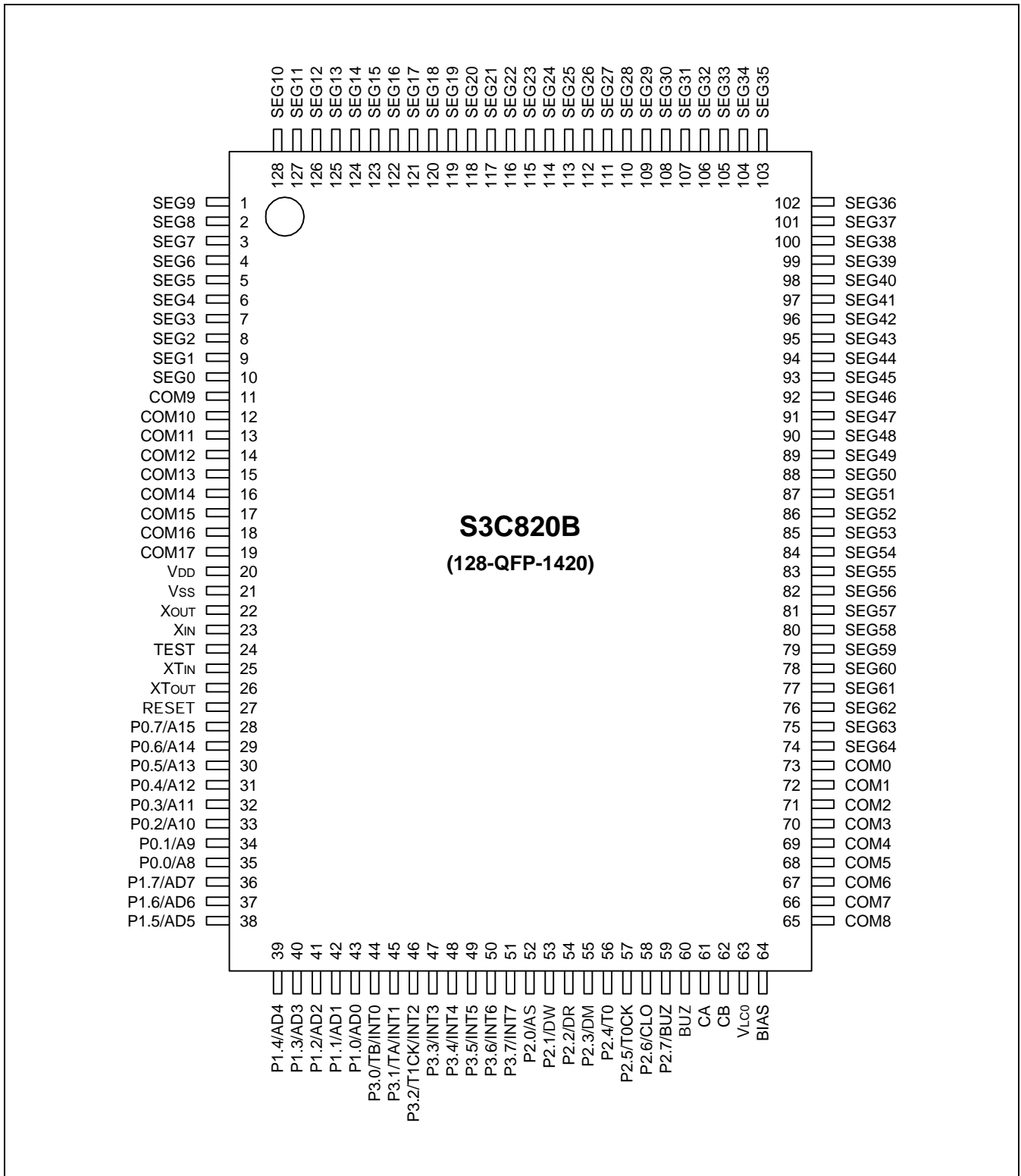

Figure 1-2. Pin Assignment (128-Pin QFP Package)

PIN DESCRIPTIONS

Table 1-1. Pin Descriptions

Pin Names	Pin Type	Pin Description	Circuit Type	Pin No.	Shared Functions
P0.0–P0.7	I/O	I/O port with nibble-programmable pins; schmitt trigger input or push-pull, open-drain output and software assignable pull-up; also configurable as external interface address lines A8–A15.	3	35–28	A8–A15
P1.0–P1.7	I/O	Same general characteristics as port 0; also configurable as external interface address/data lines AD0–AD7.	3	43–36	AD0–AD7
P2.0–P2.3	I/O	I/O port with bit-programmable pins; schmitt trigger input or push-pull output and software assignable pull-ups. Lower nibble pins 0–3 are configurable for external interface signals.	5	52–55	AS, DW, DR, DM
P2.4–P2.7	I/O	P2.4/capture input, interval/PWM output (T0) P2.5/timer 0 clock input (T0CK) P2.6/system clock output (CLO) P2.7/buzzer signal output (BUZ)	6	56–59	T0, T0CK, CLO, BUZ
P3.0–P3.7	I/O	I/O port with bit-programmable pins; schmitt trigger input or push-pull output and software assignable pull-up; P3.0–P3.7 are alternately used for external interrupt input (noise filters, interrupt enable and pending control); P3.0/timer B clock output (TB)/INT0 P3.1/timer 1/A clock output (TA)/INT1 P3.2/timer 1/A clock input (T1CK)/INT2	4	44–51	TB/INT0, TA/INT1, T1CK/INT2, INT3–INT7
T1CK	I/O	Timer A external clock input pins.	4	46	P3.2/INT2
TB TA	I/O	Timer B and 1/A clock output pins.	4	44 45	P3.0/INT0 P3.1/INT1
AS, DW, DR, DM	I/O	Output pins for external interface control signals. AS: address strobe DW: data memory write DR: data memory read DM: data memory select	5	52–55	P2.0–P2.3
T0	I/O	Capture input or interval/PWM output.	6	56	P2.4
T0CK	I/O	Timer 0 clock input.	6	57	P2.5

Table 1-1. Pin Descriptions (Continued)

Pin Names	Pin Type	Pin Description	Circuit Type	Pin No.	Shared Functions
CLO	I/O	Clock output	6	58	P2.6
BUZ	I/O	Output pin for buzzer signal.	6	59	P2.7
BUZ	O	Inverted buzzer signal output.	–	60	–
INT0–INT7	I/O	External interrupt input pins.	4	44–51	P3.0/TB, P3.1/TA, P3.2/T1CK, P3.3–P3.7
AD0–AD7	I/O	Address low and data ports.	3	43–36	P1.0–P1.7
A8–A15	I/O	Address high output ports.	3	35–28	P0.0–P0.7
COM0–COM8	O	LCD common signal output.	7	73–65	–
COM9–COM17	O	LCD common signal output.	7	11–19	–
SEG0–SEG64	O	LCD seg signal output.	8	10–1 128–74	–
CA, CB	–	Capacitor terminal for voltage doubling.	–	61, 62	–
V _{LC0}	–	LCD power supply.	–	63	–
BIAS	O	Bias voltage level for LCD driving.	–	64	–
RESET	I	System reset pin	2	27	–
XT _{IN} , XT _{OUT}	–	Crystal oscillator pins for sub clock.	–	25, 26	–
TEST	I	Test signal input (must be connected to V _{DD}).	–	24	–
X _{IN} , X _{OUT}	–	Main oscillator pins	–	23, 22	–
V _{DD} , V _{SS}	–	Power input pins	–	20, 21	–

PIN CIRCUIT DIAGRAMS

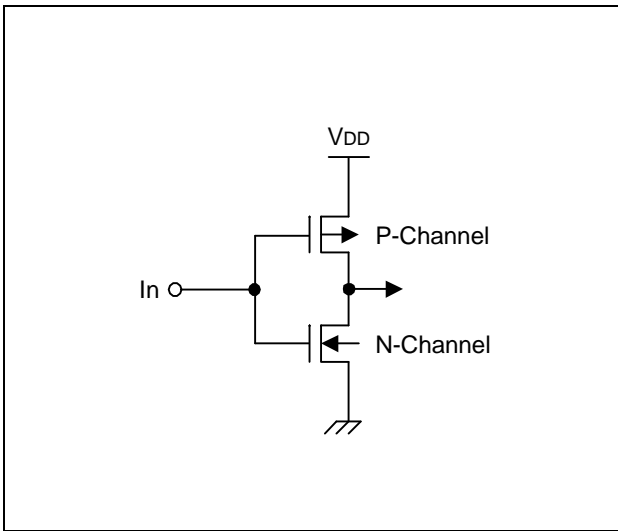

Figure 1-3. Pin Circuit Type 1

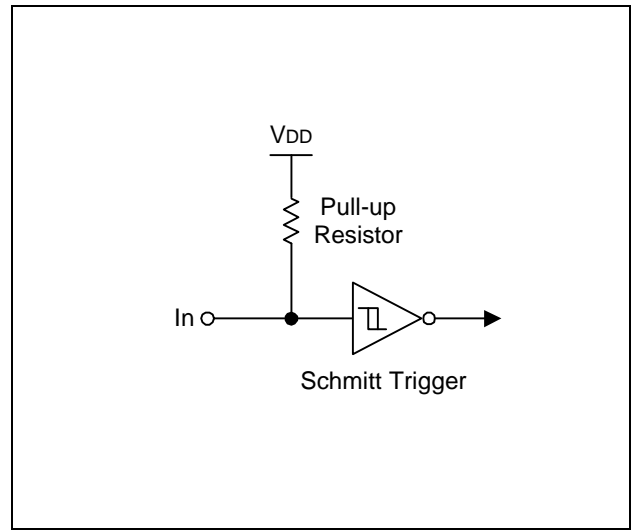

Figure 1-4. Pin Circuit Type 2 (RESET)

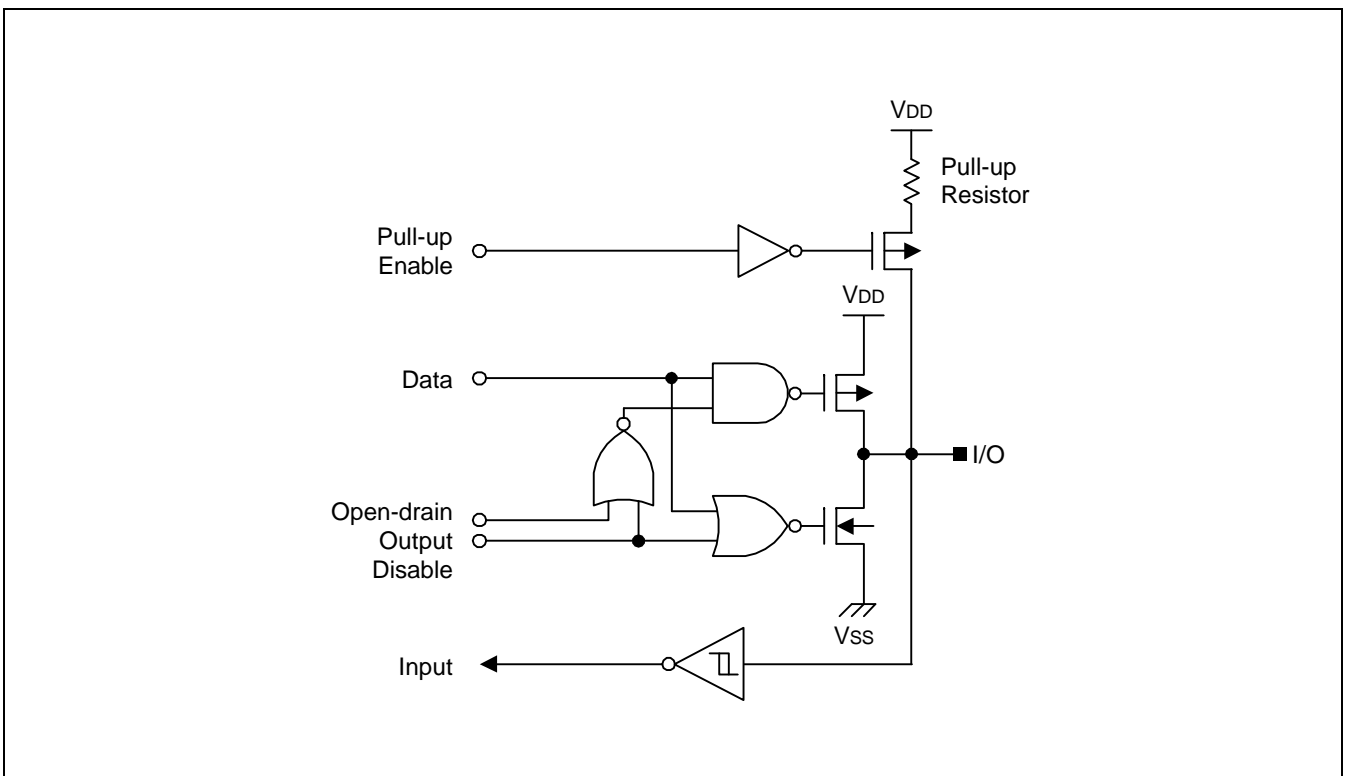

Figure 1-5. Pin Circuit Type 3 (Ports 0, 1)

PIN CIRCUIT DIAGRAMS (Continued)

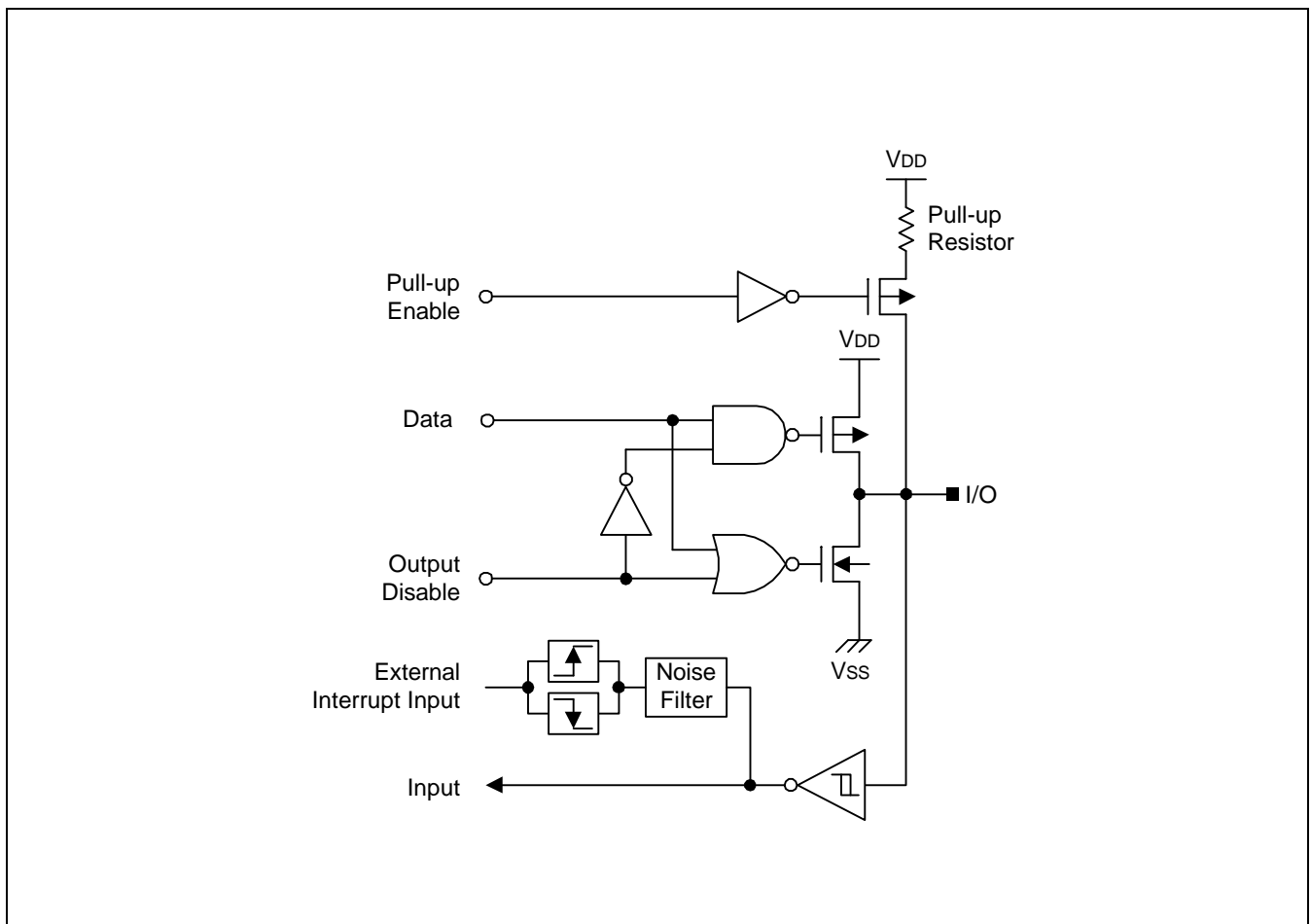

Figure 1-6. Pin Circuit Type 4 (Port 3)

PIN CIRCUIT DIAGRAMS (Continued)

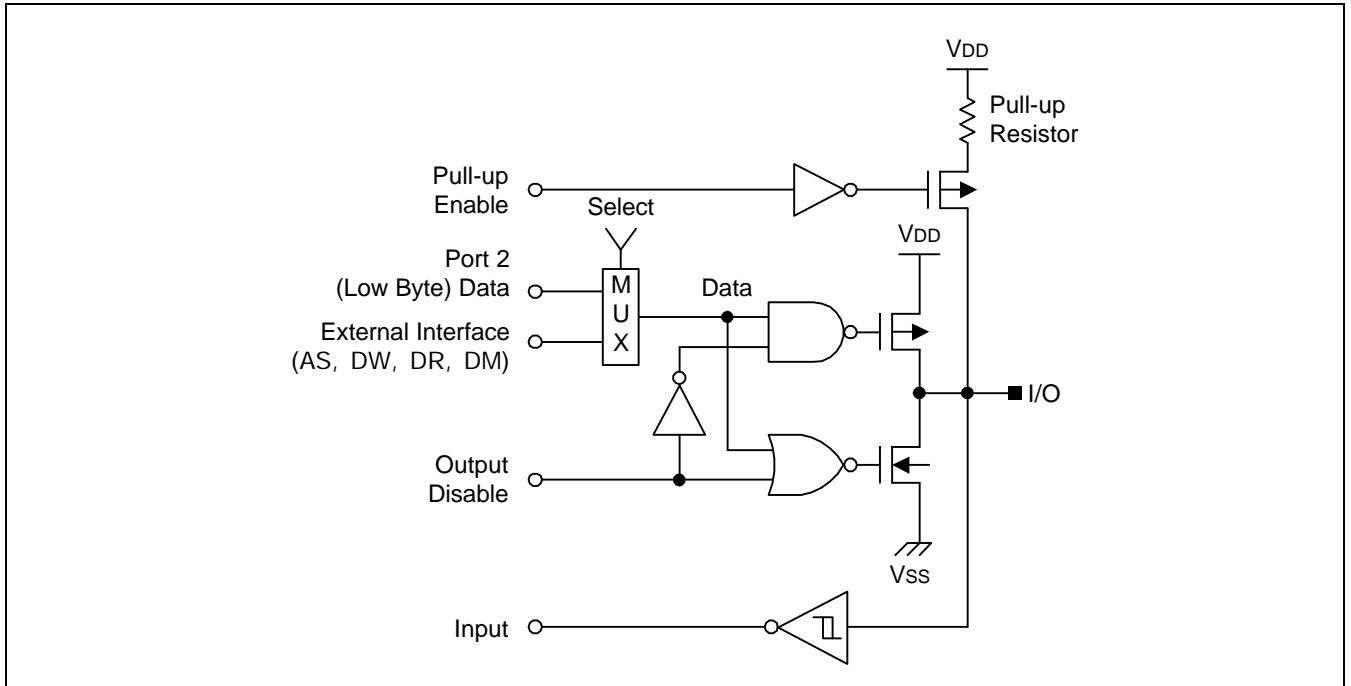

Figure 1-7. Pin Circuit Type 5 (Ports 2.0-2.3)

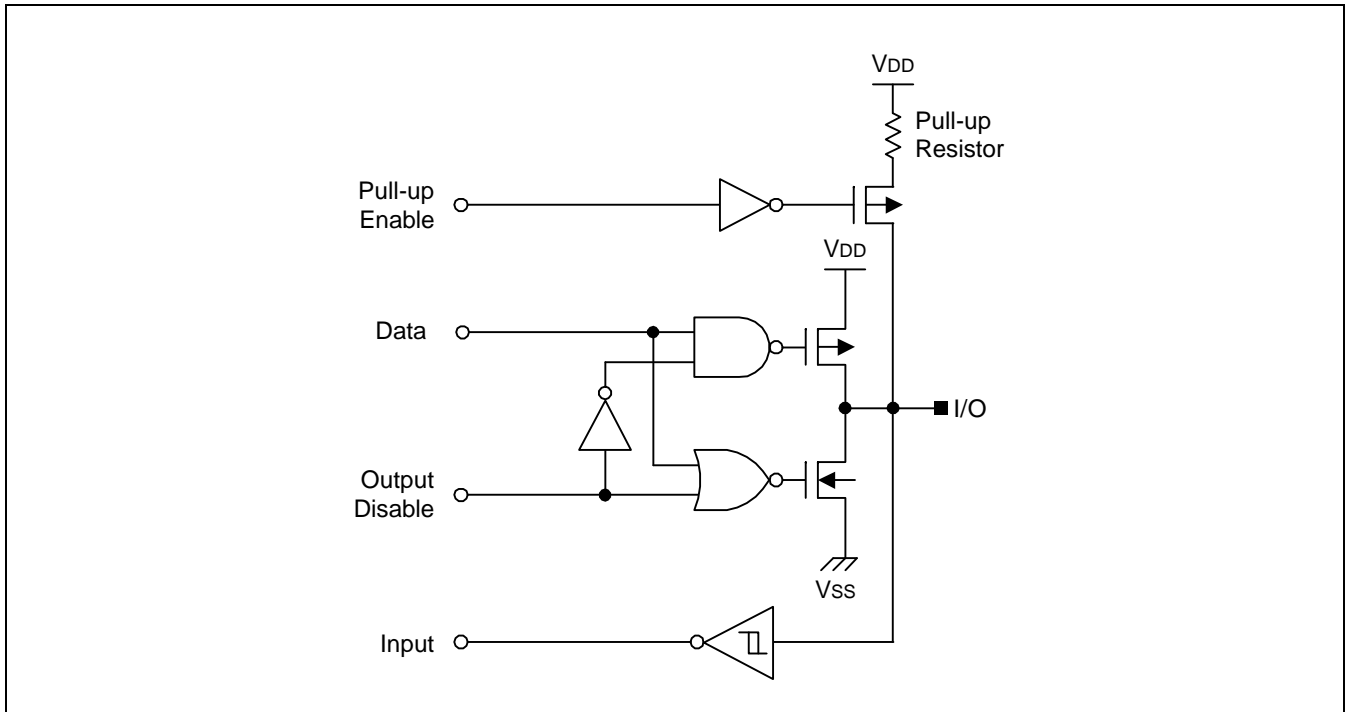

Figure 1-8. Pin Circuit Type 6 (Ports 2.4-2.7)

PIN CIRCUIT DIAGRAMS (Continued)

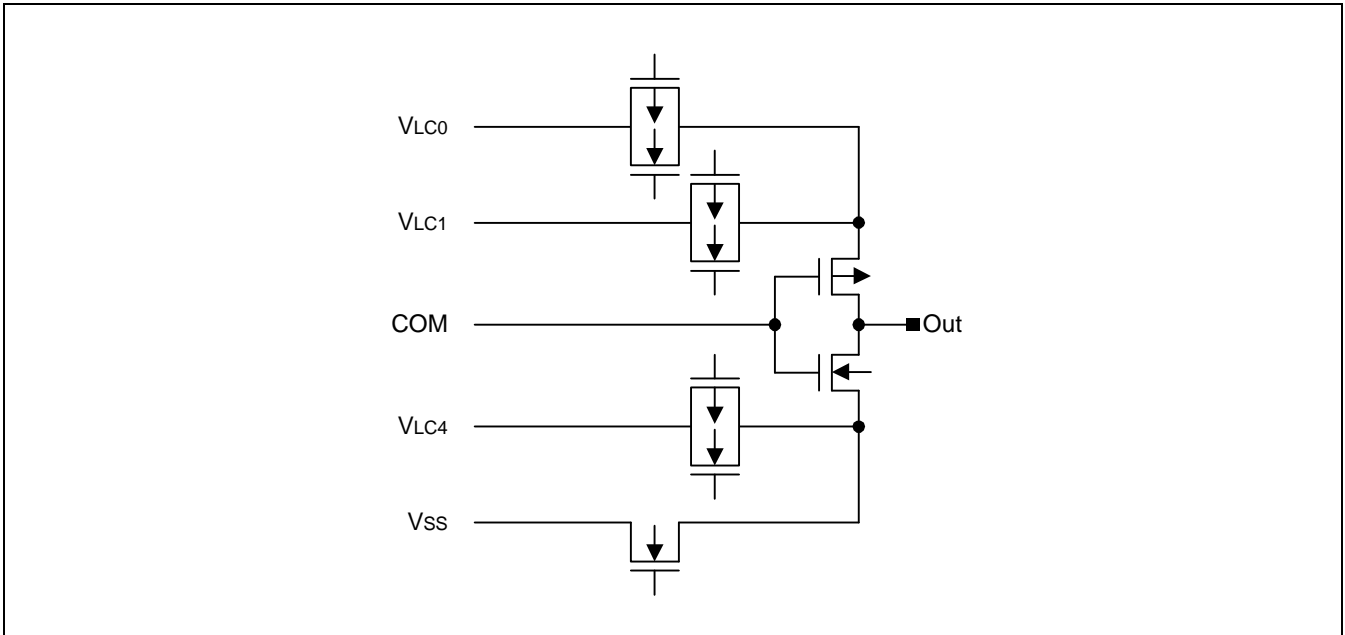

Figure 1-9. Pin Circuit Type 7 (COM0-COM17)

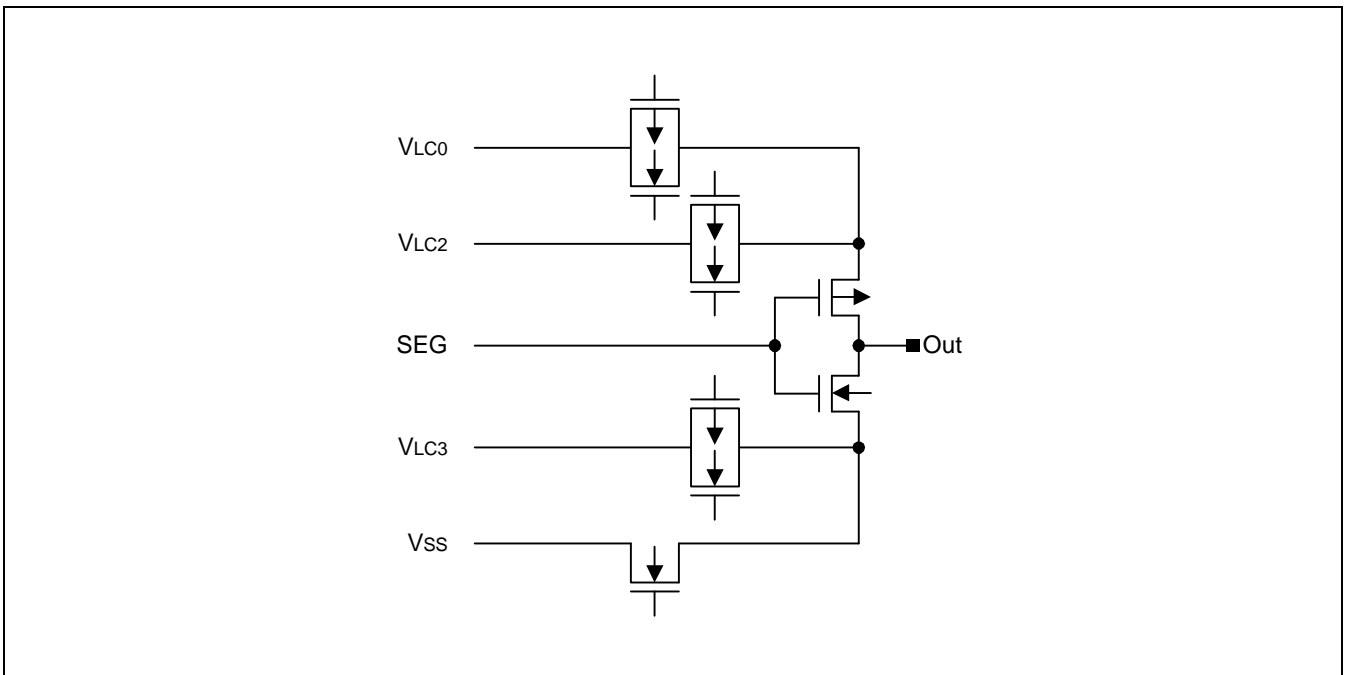

Figure 1-10. Pin Circuit Type 8 (SEG0-SEG64)

15 ELECTRICAL DATA

OVERVIEW

In this chapter, S3C820B electrical characteristics are presented in tables and graphs. The information is arranged in the following order:

- Absolute maximum ratings
- D.C. electrical characteristics
- Data retention supply voltage in Stop mode
- Stop mode release timing when initiated by an external interrupt
- Stop mode release timing when initiated by a Reset
- I/O capacitance
- A.C. electrical characteristics
- Input timing for external interrupts (port 0, P2.3–P2.0)
- Input timing for RESET
- Oscillation characteristics
- Oscillation stabilization time

Table 15-1. Absolute Maximum Ratings

 $(T_A = 25\text{ }^\circ\text{C})$

Parameter	Symbol	Conditions	Rating	Unit
Supply voltage	V_{DD}	–	– 0.3 to + 5.5	V
Input voltage	V_{IN}	Ports 0, 1, 2, and 3	– 0.3 to $V_{DD} + 0.3$	V
Output voltage	V_O	All output pins	– 0.3 to $V_{DD} + 0.3$	V
Output current High	I_{OH}	One I/O pin active	– 18	mA
		All I/O pins active	– 60	
Output current Low	I_{OL}	One I/O pin active	+ 30	mA
		Total pin current for ports 0–3	+ 100	
Operating temperature	T_A	–	– 40 to + 85	$^\circ\text{C}$
Storage temperature	T_{STG}	–	– 65 to + 150	$^\circ\text{C}$

Table 15-2. D.C. Electrical Characteristics

(T_A = -40 °C to +85 °C, V_{DD} = 2.2 V to 4.5 V)

Parameter	Symbol	Conditions	Min	Typ	Max	Unit
Input High voltage	V _{IH1}	All input pins except V _{IH2} and V _{IH3}	0.8 V _{DD}	-	V _{DD}	V
	V _{IH2}	RESET	0.8 V _{DD}		V _{DD}	
	V _{IH3}	X _{IN} , XT _{IN}	V _{DD} - 0.5		V _{DD}	
Input Low voltage	V _{IL1}	All input pins except V _{IL2} and V _{IL3}	0	-	0.2 V _{DD}	
	V _{IL2}	RESET			0.2 V _{DD}	
	V _{IL3}	X _{OUT} , XT _{OUT}			0.5	
Output High voltage	V _{OH}	V _{DD} = 3.0 V; I _{OH} = -1 mA All output pins	V _{DD} - 1.0	-	-	
Output Low voltage	V _{OL}	V _{DD} = 3.0 V; I _{OL} = 2 mA All output pins	-	-	1.0	
Input High leakage current	I _{LIH1}	V _{IN} = V _{DD} ; all input pins except X _{IN} , X _{OUT} , XT _{IN} , and XT _{OUT}	-	-	1	μA
	I _{LIH2}	V _{IN} = V _{DD} ; X _{IN} , X _{OUT} , XT _{IN} , and XT _{OUT}			20	
Input Low leakage current	I _{LIL1}	V _{IN} = 0 V; all input pins except X _{IN} , X _{OUT} , XT _{IN} , and XT _{OUT}	-	-	-1	
	I _{LIL2}	V _{IN} = 0 V; X _{IN} , X _{OUT} , XT _{IN} , and XT _{OUT}			-20	
Output High leakage current	I _{LOH}	V _{OUT} = V _{DD} All output pins	-	-	1	
Output Low leakage current	I _{LOL}	V _{OUT} = 0 V All output pins	-	-	-1	

Table 15-2. D.C. Electrical Characteristics (Continued)

(T_A = -40°C to +85°C, V_{DD} = 2.2 V to 4.5 V)

Parameter	Symbol	Conditions	Min	Typ	Max	Unit	
Middle output voltage	V _{OM1}	V _{MN} = V _{LCD} - (N/5) × V _{LCD} N = 1, 2, 3, and 4	COM0-17	V _{M1} - 0.2	V _{M1}	V _{M1} + 0.2	V
	V _{OM2}		SEG0-64	V _{M2} - 0.2	V _{M2}	V _{M2} + 0.2	
	V _{OM3}		SEG0-64	V _{M3} - 0.2	V _{M3}	V _{M3} + 0.2	
	V _{OM4}		COM0-17	V _{M4} - 0.2	V _{M4}	V _{M4} + 0.2	
V _{LCD} - V _{COMi} voltage drop (i = 0-17)	V _{DC}	V _{LCD} = 3.0 V to 6.0 V - 15 μA per common pin	-	-	120	mV	
V _{LCD} - V _{SEGx} voltage drop (x = 0-64)	V _{DS}	V _{LCD} = 3.0 V to 6.0 V - 15 μA per common pin	-	-	120	mV	
LCD driving voltage	V _{LCD}	-	3.0	-	6.0	V	
Pull-up resistors	R _{L1}	V _{IN} = 0 V; T _A = 25 °C; V _{DD} = 3.0 V Ports 0, 1, 2, and 3	30	80	200	kΩ	
	R _{L2}	V _{IN} = 0 V; T _A = 25 °C; V _{DD} = 3.0 V RESET only	300	500	800		
LCD voltage dividing resistor	R _{LCD}	V _{LCD} = 3.0 V to 6.0 V T _A = 25 °C	40	60	80	kΩ	
Supply current (note)	I _{DD1}	V _{DD} = 3.0 V ± 10% 2 MHz crystal	-	1.5	3.5	mA	
	I _{DD2}	Idle mode; V _{DD} = 3.0 V ± 10% 2 MHz crystal		0.5	1.5		
	I _{DD3}	V _{DD} = 3.0 V ± 10% 32 kHz crystal		30	70	μA	
	I _{DD4}	Idle mode; V _{DD} = 3.0 V ± 10% 32 kHz crystal		6	12		
	I _{DD5}	Stop mode; V _{DD} = 3.0 V ± 10% XT _{IN} = 0 V		0.5	1		

NOTES:

- Supply current does not include current drawn through internal pull-up resistors, LCD voltage dividing resistors, voltage doubler, or external output current loads.
- I_{DD1} and I_{DD2} include power consumption for subsystem clock oscillation.
- I_{DD3} and I_{DD4} are current when main system clock oscillation stops and the subsystem clock is used.

Table 15-3. Data Retention Supply Voltage in Stop Mode

($T_A = -40\text{ }^\circ\text{C}$ to $+85\text{ }^\circ\text{C}$)

Parameter	Symbol	Conditions	Min	Typ	Max	Unit
Data retention supply voltage	V_{DDDR}	–	2.2	–	4.5	V
Data retention supply current	I_{DDDR}	$V_{DDDR} = 2.2\text{ V}$	–	–	5	μA
Release signal set time	t_{SREL}	–	0	–	–	μs
Oscillator stabilization wait time	t_{WAIT}	Released by RESET	–	$2^{16}/f_x$ (1)	–	ms
		Released by interrupt	–	(2)	–	

NOTES:

1. f_x is the main oscillator frequency.
2. The duration of the oscillation stabilization time (t_{WAIT}) when it is released by an interrupt is determined by the setting in the basic timer control register, BTCON.

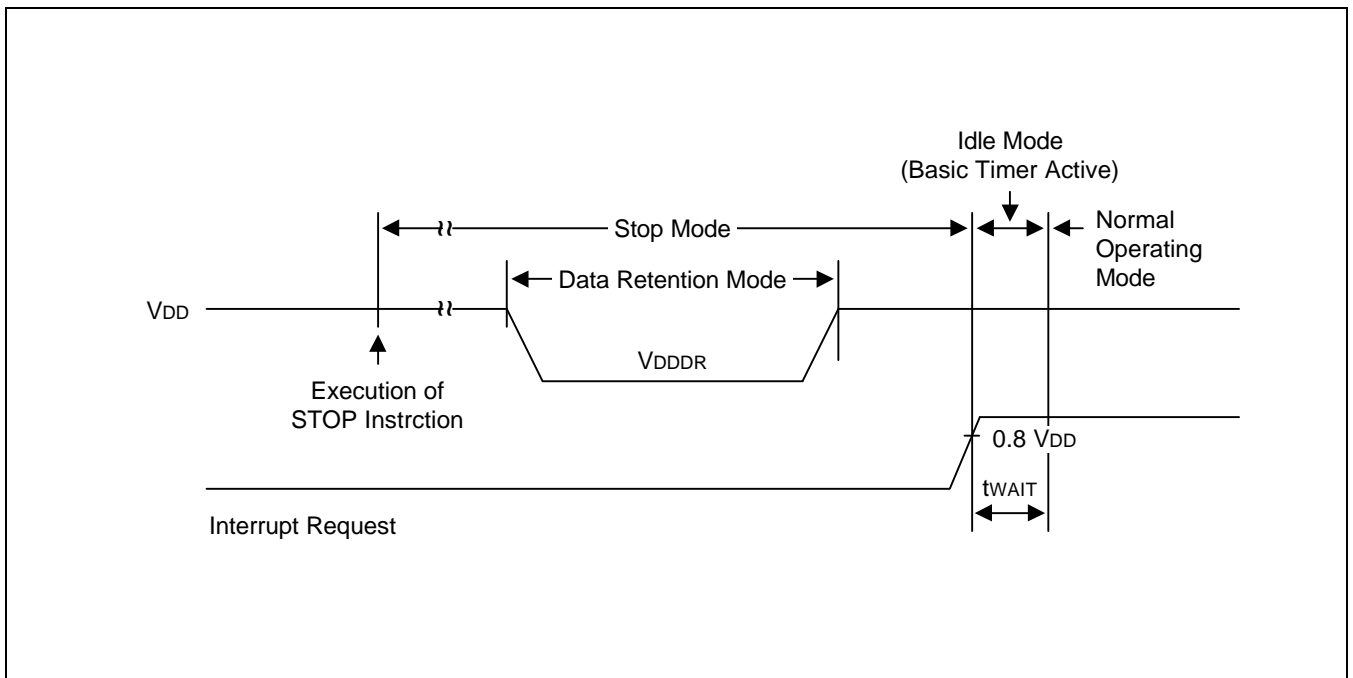

Figure 15-1. Stop Mode Release Timing When Initiated by an External Interrupt

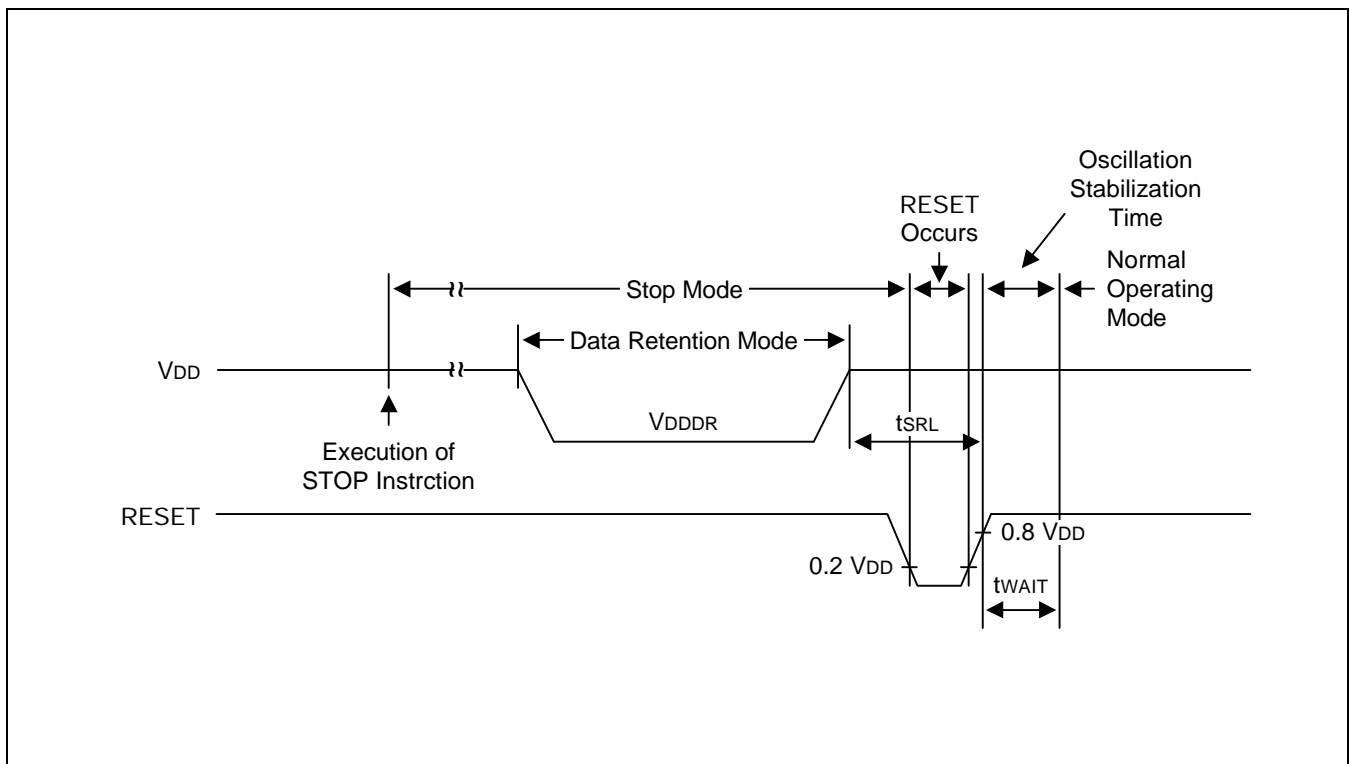

Figure 15-2. Stop Mode Release Timing When Initiated by a RESET

Table 15-4. Input/Output Capacitance

 $(T_A = -40\text{ }^\circ\text{C to } +85\text{ }^\circ\text{C}, V_{DD} = 0\text{ V})$

Parameter	Symbol	Conditions	Min	Typ	Max	Unit
Input capacitance	C_{IN}	$f = 1\text{ MHz}$; unmeasured pins are connected to V_{SS}	–	–	10	μF
Output capacitance	C_{OUT}					
I/O capacitance	C_{IO}					

Table 15-5. A.C. Electrical Characteristics

 $(T_A = -40\text{ }^\circ\text{C to } +85\text{ }^\circ\text{C})$

Parameter	Symbol	Conditions	Min	Typ	Max	Unit
Interrupt input, High, Low width	t_{INTH} , t_{INTL}	P3.0–P3.7 $V_{DD} = 3\text{ V}$	500	700	–	ns
RESET input Low width	t_{RSL}	Input $V_{DD} = 3\text{ V}$	2000	–	–	

Table 15-6. Voltage Doubler Output

 $(T_A = -40\text{ }^\circ\text{C to } +85\text{ }^\circ\text{C})$

Parameter	Symbol	Conditions	Min	Typ	Max	Unit
Voltage Doubler Output	V_{BIAS}	$V_{DD} = 3\text{ V} \pm 10\%$ only	$2 V_{DD} - 0.5$	$2 V_{DD}$	$2 V_{DD} + 0.5$	V

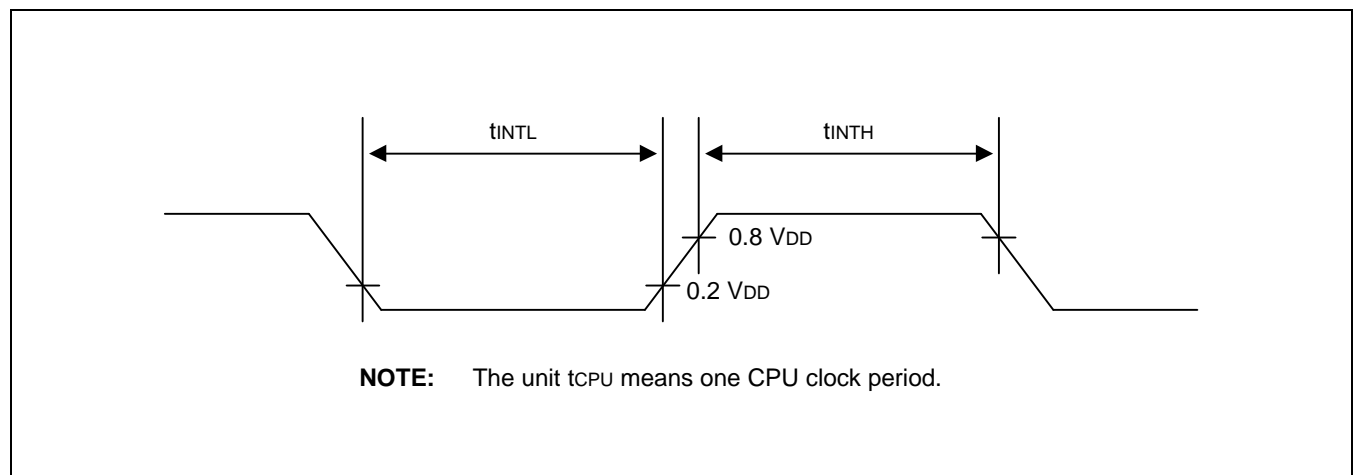

Figure 15-3. Input Timing for External Interrupts (P3.0–P3.7)

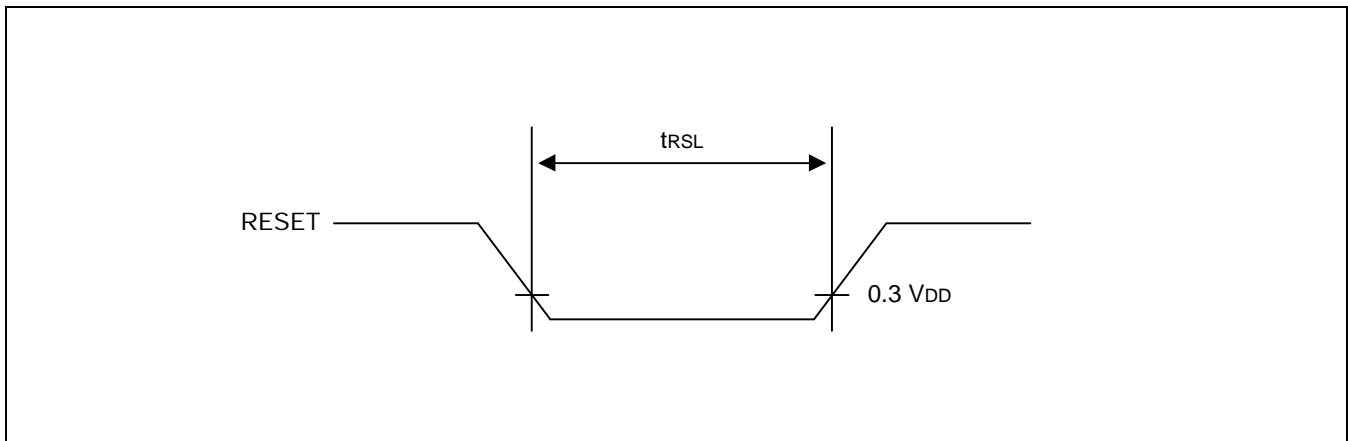

Figure 15-4. Input Timing for RESET

Table 15-7. Main Oscillation Characteristics

($T_A = -40\text{ }^\circ\text{C} + 85\text{ }^\circ\text{C}$, $V_{DD} = 2.2\text{ V}$ to 4.5 V)

Oscillator	Clock Circuit	Conditions	Min	Typ	Max	Unit
Crystal		CPU clock oscillation frequency	0.4	–	4	MHz
Ceramic		CPU clock oscillation frequency	0.4	–	4	MHz
External clock		X_{IN} input frequency	0.4	–	4	MHz
RC		Frequency, $V_{DD} = 3\text{ V}$	0.4	–	2	MHz

Table 15-8. Sub Oscillation Characteristics

($T_A = -40\text{ }^\circ\text{C} + 85\text{ }^\circ\text{C}$, $V_{DD} = 2.2\text{ V to } 4.5\text{ V}$)

Oscillator	Clock Circuit	Conditions	Min	Typ	Max	Unit
Crystal		CPU clock oscillation frequency	32	32.768	35	kHz
External clock		$X_{T_{IN}}$ input frequency	32	–	500	kHz

Table 15-9. Main Oscillation Stabilization Time

($T_A = -40\text{ }^\circ\text{C} + 85\text{ }^\circ\text{C}$, $V_{DD} = 3.0\text{ V} \pm 10\%$)

Oscillator	Test Condition	Min	Typ	Max	Unit
Crystal	$f_x > 400\text{ kHz}$	–	–	80	ms
Ceramic	Oscillation stabilization occurs when V_{DD} is equal to the minimum oscillator voltage range.	–	–	50	ms
External clock	X_{IN} input High and Low width (t_{XH} , t_{XL})	25	–	700	ns

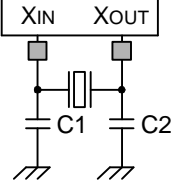
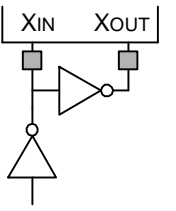
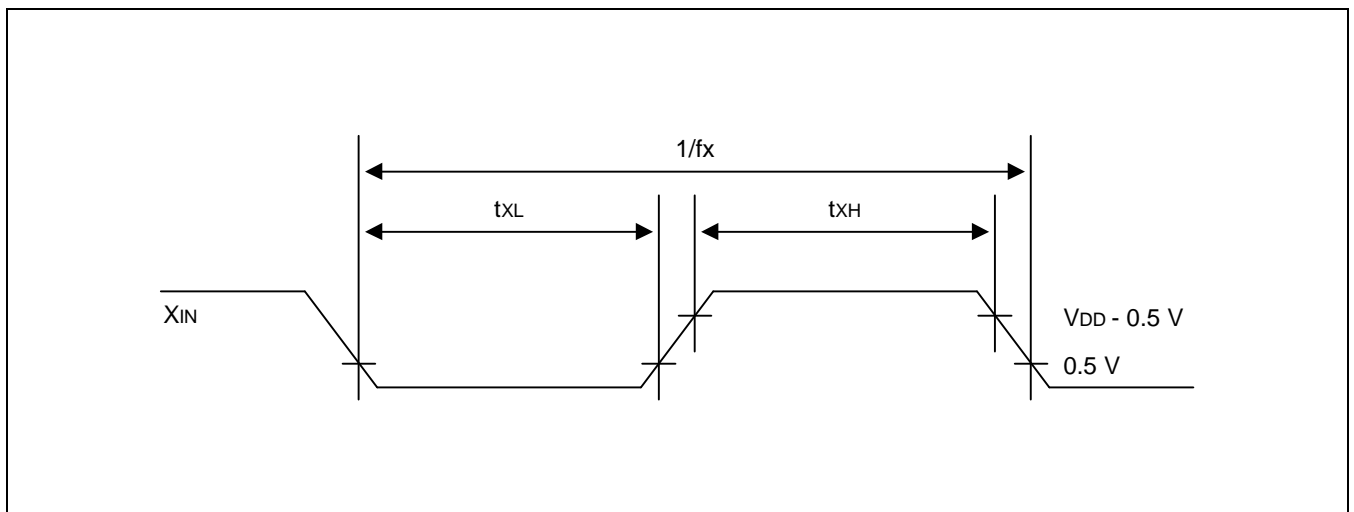
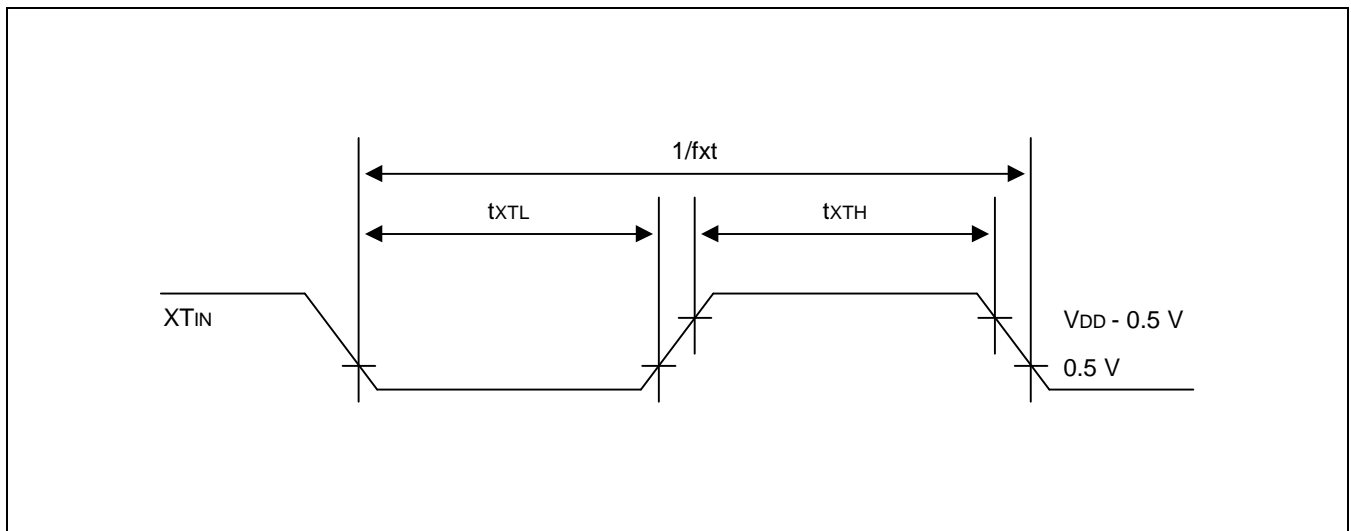

Figure 15-5. Clock Timing Measurement at X_{IN}

Table 15-10. Sub Oscillation Stabilization Time

($T_A = -40\text{ }^\circ\text{C} + 85\text{ }^\circ\text{C}$, $V_{DD} = 3.0\text{ V} \pm 10\%$)

Oscillator	Test Condition	Min	Typ	Max	Unit
Crystal	–	–	1.0	2	s
External clock	X_{IN} input High and Low width (t_{XH} , t_{XL})	1	–	18	μs

Figure 15-6. Clock Timing Measurement at X_{TIN}

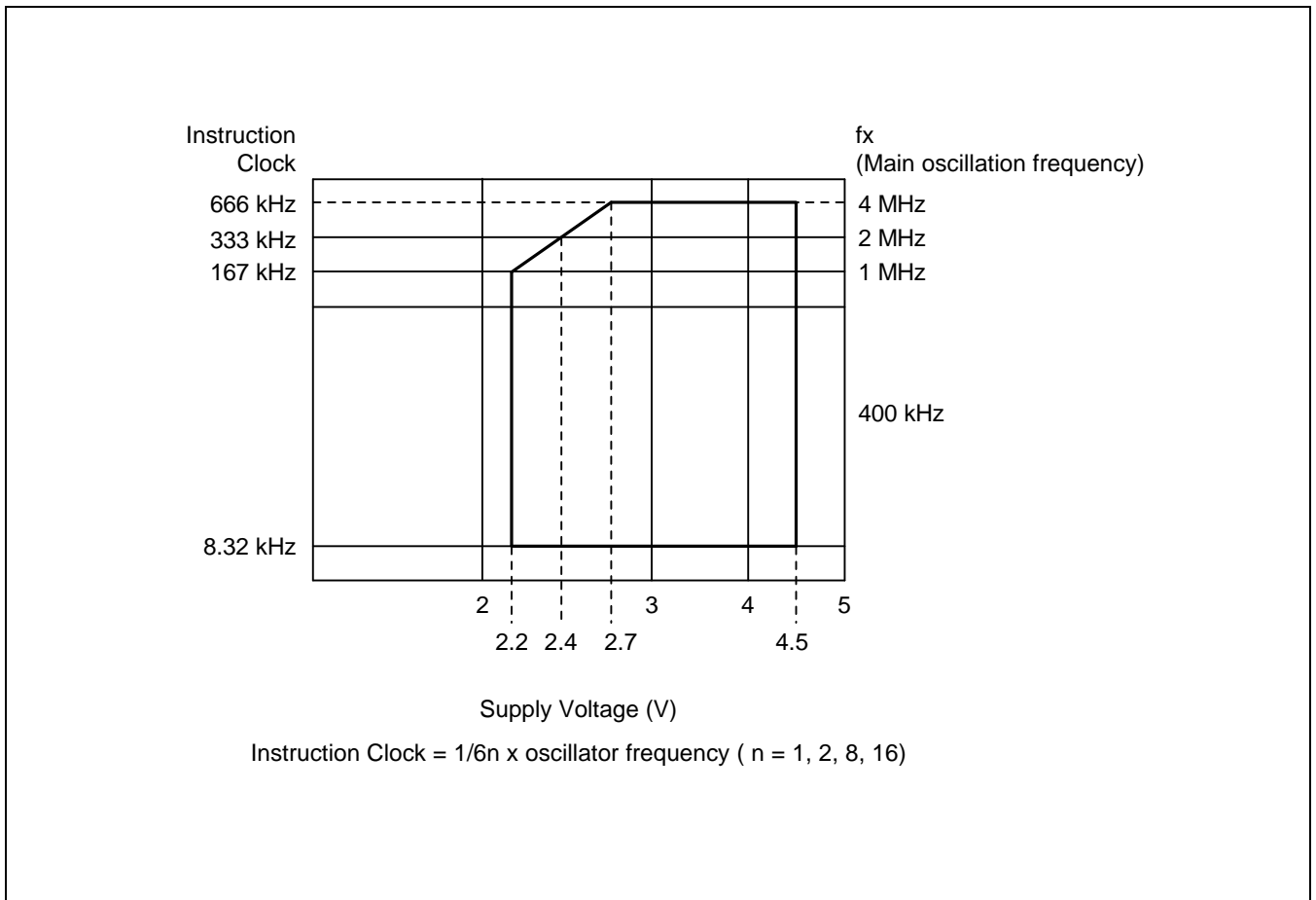

Figure 15-7. Operating Voltage Range

16 MECHANICAL DATA

OVERVIEW

The S3C820B microcontroller is currently available in a 128-pin TQFP package.

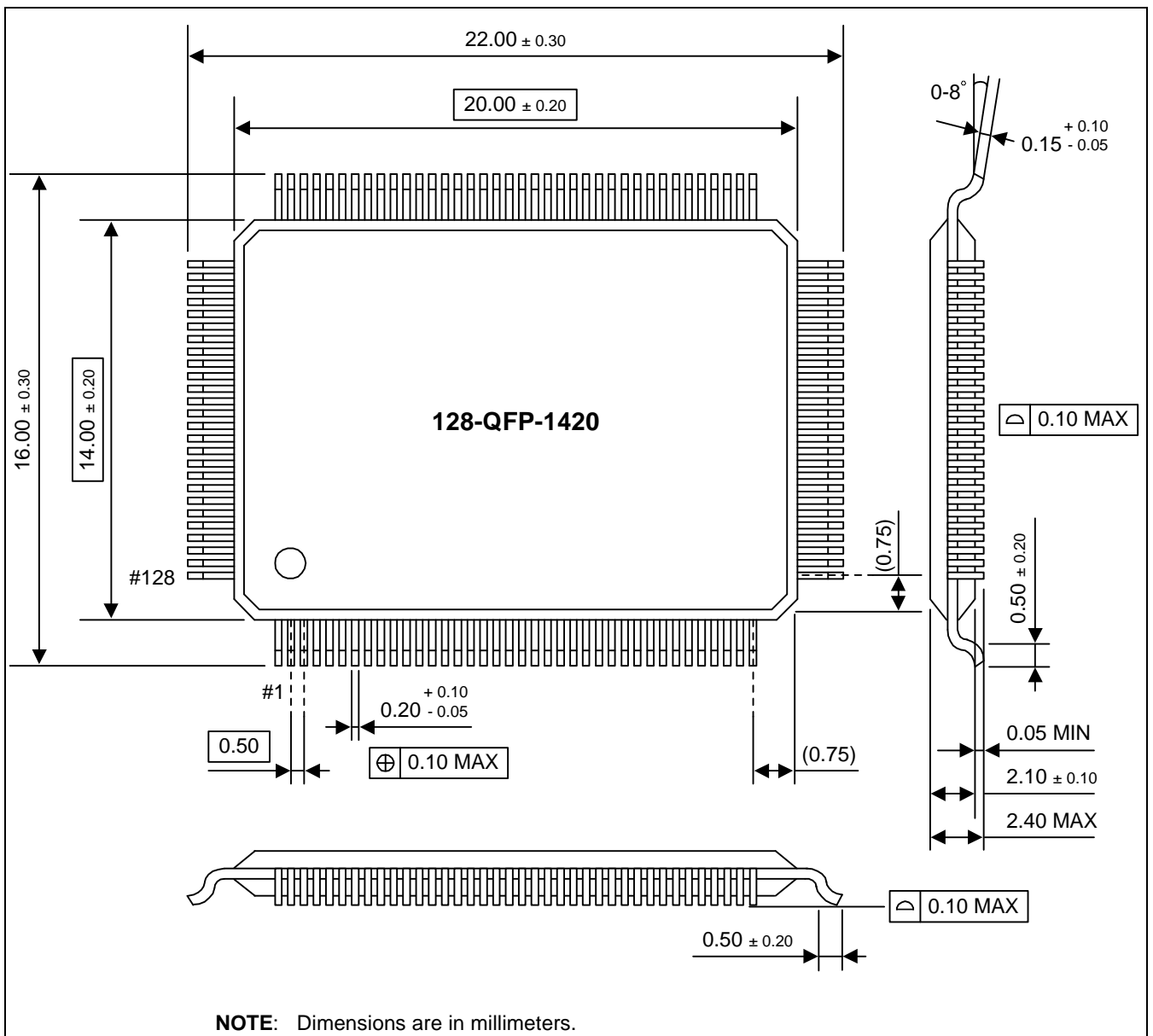

Figure 16-1. 128-Pin TQFP Package Mechanical Data