

Plastic single-ended package; heatsink mounted; 1 mounting hole; 5-lead TO-220

SOT263

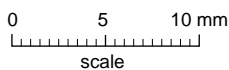
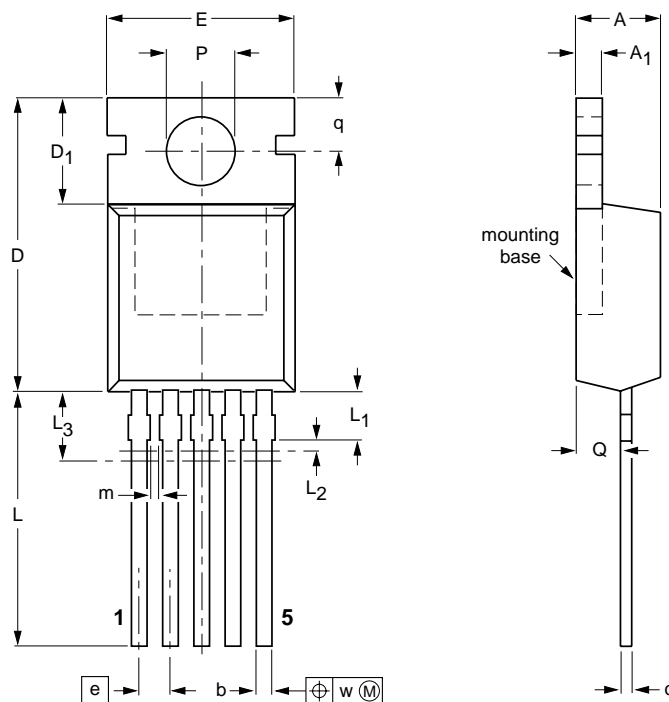

DIMENSIONS (mm are the original dimensions)

UNIT	A	A ₁	b	c	D	D ₁	E	e	L	L ₁ ⁽¹⁾	L ₂ ⁽²⁾	L ₃ ⁽³⁾ max.	m	P	q	Q	w
mm	4.5 4.1	1.39 1.27	0.9 0.7	0.7 0.4	15.8 15.2	6.4 5.9	10.3 9.7	1.7	15.0 13.5	2.4 1.6	0.5	3.5	0.8 0.6	3.8 3.6	3.0 2.7	2.6 2.2	0.4

Notes

1. Terminal dimensions are uncontrolled in this zone.
2. Positional accuracy of the terminals is controlled in this zone.
3. Terminals in this zone are not tinned.

OUTLINE VERSION	REFERENCES				EUROPEAN PROJECTION	ISSUE DATE
	IEC	JEDEC	EIAJ			
SOT263		5-lead TO-220				97-06-11