

**OC-X87XXXXX Series**

Micro-miniature OCXO

**Features**

- Low Cost DIL 14 package
- High Vacuum Sealed Crystal
- Low Power Consumption (500 mW)
- Fast Warm-up Time (2 minutes)
- Stratum3 or better Stability
- Low Aging < 3 ppm over life
- Very Low Phase Noise (-160dBc/Hz TYP)
- HCMOS/TTL or Sine-Wave output
- 8 MHz to 160 MHz Frequencies Available
- Voltage Control Optional

**Applications**

- Telecommunications
- Data Communications
- Instrumentation

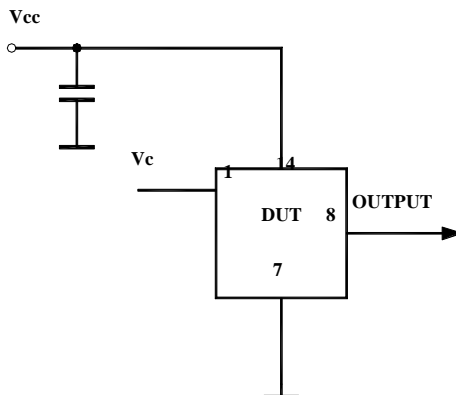
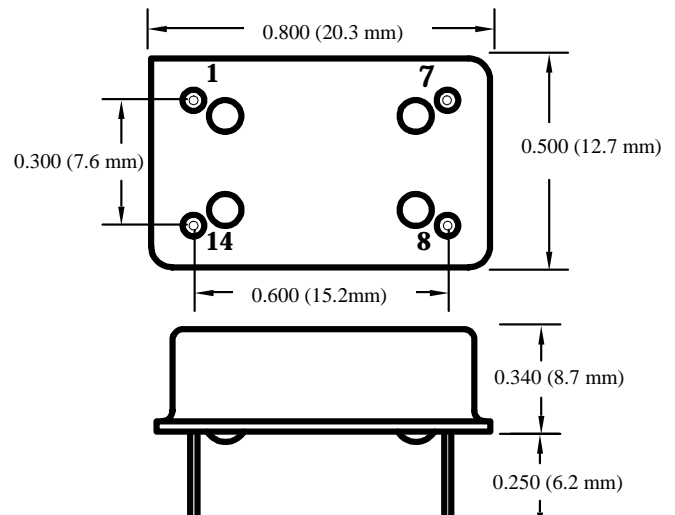
**FREQUENCY  
CONTROLS, INC.**

357 Beloit Street, P.O. Box 457, Burlington, WI 53105-0457 U.S.A. Phone 262/763-3591 FAX 262/763-2881

 Email: [nelsales@nelc.com](mailto:nelsales@nelc.com) www.nelc.com

## OC-X87XXXX Series

Micro-miniature OCXO

### Specifications:

Parameter	Symb	Condition	Min	Typ	Max	Unit	Note
<i>Absolute Maximum Ratings</i>							
Input Break Down Voltage	V <sub>cc</sub>		-0.5		5.5	V	3.3V or 5V V <sub>cc</sub> 12 V V <sub>cc</sub>
Storage temper.	T <sub>s</sub>		-40		85	°C	
Control Voltage	V <sub>c</sub>		-1		6	V	

#### Electrical

Frequency	F		8	10.000	160	MHz	1*	All parameters for 10 MHz
Frequency stability	ΔF/F	vs. Temp.		±100	±280	ppb	See chart below	
		vs. Supply		10	50	ppb/V		
Aging		per day first year 15 years		5E-9 3E-7	3E-6		after 30 days	
Allan Variance		.1s to 100s		5E-11				
Calibration		No voltage control		± 0.5	± 2	ppm		
V <sub>cc</sub> sensitivity				5E-8/V				
Load sensitivity		For 10% change			5E-8			
SSB Phase Noise		10 Hz		-100		dBc/Hz	2*	
		100 Hz		-130				
		1 KHz		-145				
		>10 KHz		-160				
Retrace		After 30 minutes			±100	ppb		
G-sensitivity		worst direction			±2.0	ppb/G		
Input Voltage	V <sub>cc</sub>		4.75	5.0	5.25	V	See chart below	
			3.15	3.3	3.45			
			11.4	12.0	12.6			
Power consumption	P	steady state, 25°C		0.5	0.7	W	Upper operating temperature < 70°C, add 20% for UOT 85°C	
		steady state, -30°C start-up			1.5 2.5			
Load		10KOhm/15pF Internally AC coupled 50 Ohm					CMOS Output Sine-wave output	
Warm-up time	τ	to 0.3 ppm accuracy		2	3	min		
Sub-Harmonics				-50	-40	dBc	At higher F 1*	
Output Waveform		3.3V HCMOS/TTL compatible, 4 ns Tr/Tf, 40/60% duty cycle Sine-wave, + 7 dBm ±3 dBm into 50 Ohm, -30 dBc harmonics					See chart below	
Control voltage	V <sub>c</sub>		0		4.0	V		
Pull range		from nominal F	±5	±10		ppm	Customer specified	
Deviation slope		Monotonic, posit		5		ppm/V	Customer specified	
Setability	V <sub>c0</sub>	@25°C, F <sub>nom</sub> .	1.0	2.0	3.0	V	5V/3.3 supply	

#### Environmental and Mechanical

Operating temp. range	-30°C to 70°C Standard, Other options – see chart below
Mechanical Shock	Per MIL-STD-202, 30G, 11ms
Vibration	Per MIL-STD-202, 5G to 2000 Hz
Soldering Conditions	Leads Temperature 260°C, for 10s, Max
Hermetic Seal	Leak rate less than 1x10 <sup>-8</sup> atm.cm/s of helium

#### Electrical Connections

Pin Out	Pin 1- V <sub>c</sub> ; Pin 7- Case, GND; Pin8 – Output; Pin 14 - V <sub>cc</sub>
---------	---

## OC-X87XXXX Series

Micro-miniature OCXO

### Creating a Part Number

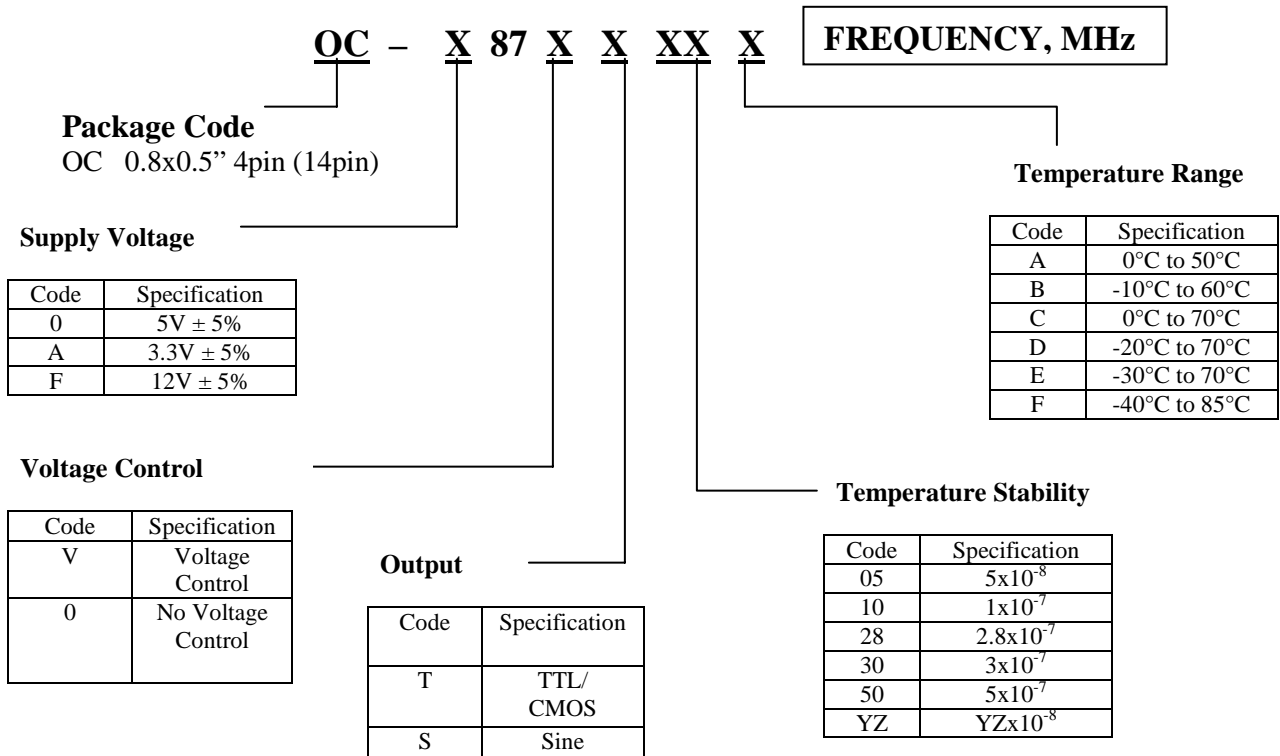

Not all combinations are available. Consult Factory.

**Notes:**

1\* Higher frequencies can be achieved either by using higher frequency crystals or by low noise analog harmonic multiplication. Both methods have advantages and drawbacks. If lowest possible phase noise on the noise floor is most important – high frequency crystal will be used. If phase noise close to the carrier and aging are more important – multiplication will be used. Please consult factory for your specific requirement.

2\* Phase noise deteriorates with frequencies going higher. If analog multiplication is used to achieve higher frequency the phase noise roughly follows the formula of additional 20LogN, where N is a multiplication factor across entire frequency offset range. If higher frequency is achieved by using higher frequency crystal phase noise close to the carrier deteriorates due to the lower Q of the crystal and is usually worse, compared to multiplied solution. On the noise floor, however it remains more or less the same.