

Lens Motor Driver for Digital Still Camera

1. Case Outline: SQFP48(7×7) Plastic Package
2. Function and Application: DSC driver
3. Absolute Maximum Ratings at Ta=25°C

Parameter	Symbol	Conditions	Ratings	Unit
Maximum supply voltage	VB max	VB power supply	10.5	V
	VCCmax	VCC power supply	10.5	
Max input application voltage	VIN max		10.5	V
Max output application voltage	VOUT max		10.5	V
Maximum output current	Io max	per CH	600	mA
Allowable power dissipation	Pd max	Substrate mounting	1.0	W
Operating temperature	Topr		-20 to +80	°C
Storage temperature	Tstg		-55 to +150	°C

(*1) Mounting substrate: 76.1mm×114.3mm×1.6mm, glass epoxy

4. Allowable Operating Ranges at Ta=25°C

Parameter	Symbol	Conditions	Ratings	Unit
Supply voltage range	VB1,2,3	(*2)	1.9 to 10	V
	VCC		1.9 to 10	
Input pin H voltage	VINH		1.8 to 10	V
Input pin L voltage	VINL		-0.3 to 0.4	V
Constant voltage setting input range	VOC	VC1,VC2	0.1 to VB	V
Constant current setting input range	VOI	IAE,ISH	0.1 to 1.0	V

(*2) NO hierarchical relationship between VB1, 2, VDD, VCC and VIN.

Example 1: VB1=VB2=VDD=2.4V(Battery power supply), VCC=4V (step-up power supply)
VIN (CPU power supply)=5V

Example 2: VB1=VB2=2.4V, VIN=3.3V, VDD=VCC=5V

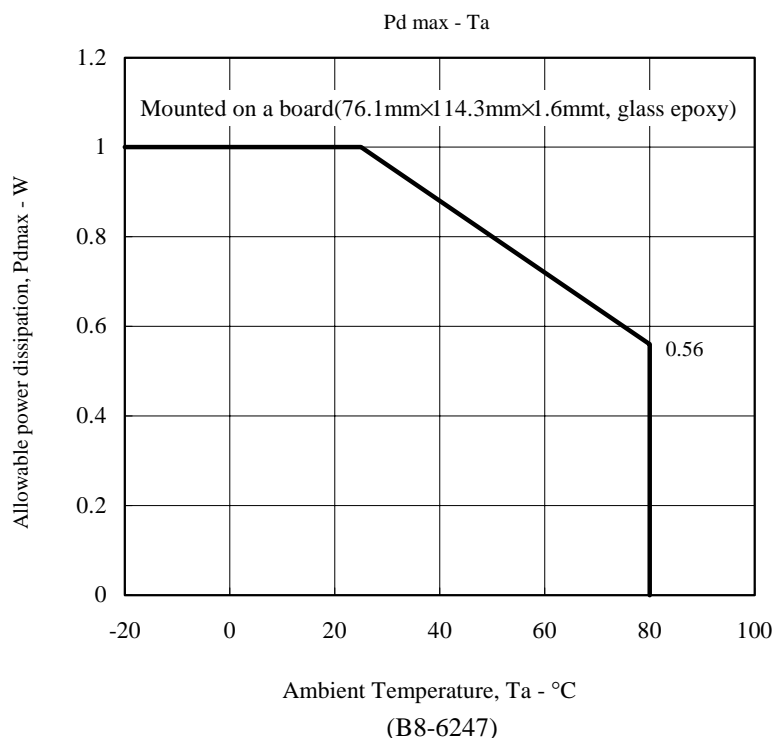

* All specs and applications shown above subject to change without prior notice.

Lens Motor Driver for Digital Still Camera

5. Electrical Characteristics (VB=VCC=2.4V, Rf=1Ω)/Ta=25°C

Parameter	Symbol	Conditions	Ratings			Unit
			Min	Typ	Max	
Standby current dissipation	ICC0	VB1=VB2=VCC=VDD=8.0V (*3)		0.1	5.0	mA
Operating current dissipation	ICC1	IN1orIN2 or IN3orIN4=H (*3)		6	9	mA
	ICC2	IN5orIN6 or IN7orIN8=H (*3)		14	19	
	ICC3	IN9orIN10 or IN11orIN12 = H (*3)		18	25	
Reference voltage	Vref1	Iref=-1mA , INHD=L	0.95	1.0	1.05	V
	Vref2	Iref=-1mA , INHD=H	0.64	0.67	0.70	
Control pin input current	I IN	VIN=5.0V		60	90	mA
Overheat protection operation temperature	THD	Design guarantee (*4)	160	180	200	°C
AF/STP constant-voltage stepping motor driver(OUT1, 2, 3, 4)						
Output constant voltage 1	VO1	VC1=0.30V	1.46	1.53	1.60	V
Output saturation voltage 1	VSAT1	Io=0.2A(Upper side + Lower side)	0.27	0.37	0.50	V
Constant-voltage driver for ZOOM (OUT5, 6, 7, 8)						
Output constant current 2	VO2	VC2=0.30V	1.46	1.53	1.60	V
Output saturation voltage 2	VSAT2	Io=0.2A(Upper side + Lower side)	0.27	0.37	0.50	V
Constant-current driver for SH/AE (OUT9, 10, 11, 12)						
Output constant current	IO	Rf=1Ω,ISH=0.3V	271	285	302	mA
Output saturation voltage 3	VSAT3	Io=0.3A(Upper side + Lower side)	0.33	0.44	0.60	V

(*3) Determined by the sum of the current drain of VB1, VB2, VDD, and VCC lines.

(*4) For characteristics within the temperature guarantee range, carry out the shipment inspection at Ta =25°C, instead of at all temperatures, for design guarantee.

* All specs and applications shown above subject to change without prior notice.

6. Pin Assignment/SQFP48

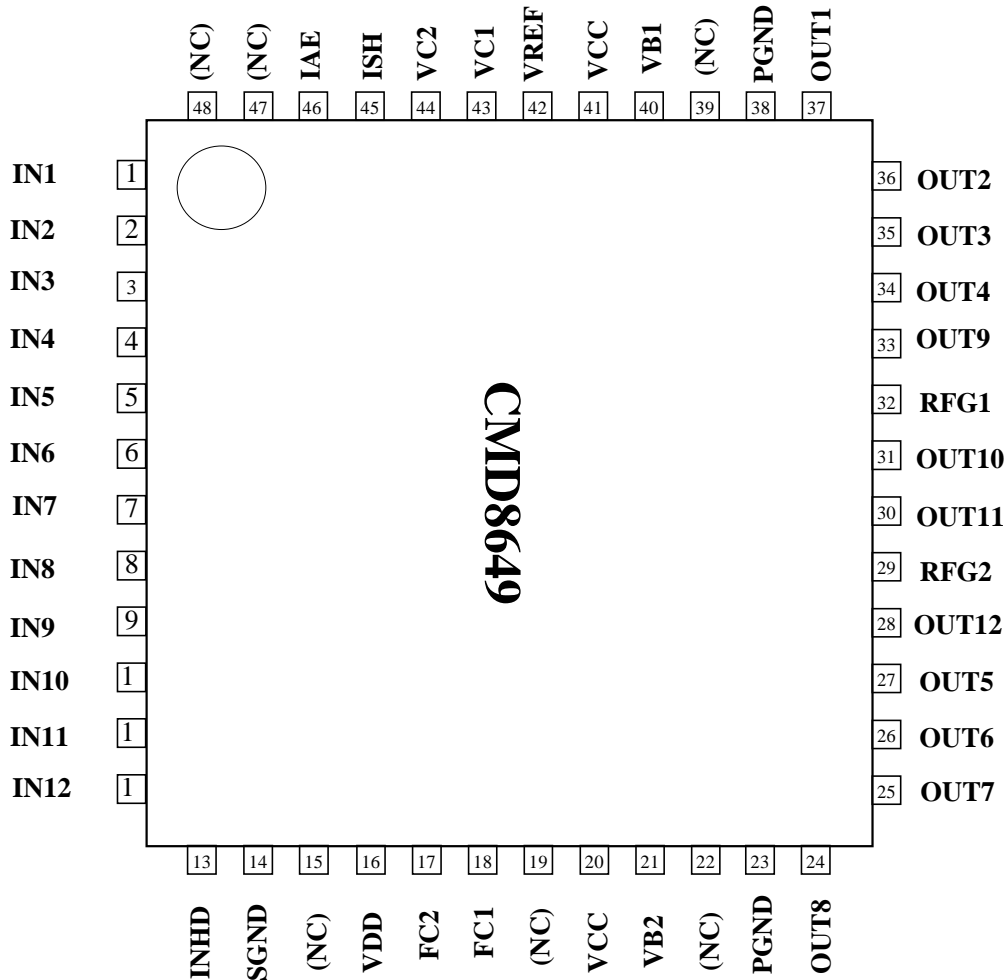

Note: Connect PGND at two points.

VDD: Input, reference voltage, logic power supply

VCC: Power supply for constant-current control and outputs (OUT9, 10, 11, and 12)

VB1: Power supply for constant-voltage control and outputs (OUT1, 2, 3, and 4)

VB2: Power supply for constant-voltage control and outputs (OUT5, 6, 7, and 8)

* All specs and applications shown above subject to change without prior notice.

Lens Motor Driver for Digital Still Camera

7. Truth Table

(1) Stepping motor constant-voltage control for AF

Input					Output					Mode	
IN1	IN2	IN3	IN4	INH D	OUT1	OUT2	OUT3	OUT4	Vref		
L	L	L	L	L	-	-	-	-	-	-	Standby
H	L	L	L	L	H	L	-	-	1.0V	1 - 2 phase excitation	
H	L	H	L		H	L	H	L			
L	L	H	L		-	-	H	L			
L	H	H	L		L	H	H	L			
L	H	L	L		L	H	-	-			
L	H	L	H		L	H	L	H			
L	L	L	H		-	-	L	H			
H	L	L	H		H	L	L	H			
H	H	*	*		-	-					
*	*	H	H				-	-			Output OFF
*	*	*	*	L					1.0V		
				H					0.67V		

:- Output OFF

For output "H", VC1×5.1 is output.

(2) Stepping motor constant-voltage control for ZOOM or DC motor drive

Input					Output					Mode	
IN5	IN6	IN7	IN8	INH D	OUT5	OUT6	OUT7	OUT8	Vref		
L	L	L	L	L	-	-	-	-	-	-	Standby
H	L	L	L	L	H	L	-	-	1.0V	1 - 2 phase excitation	
H	L	H	L		H	L	H	L			
L	L	H	L		-	-	H	L			
L	H	H	L		L	H	H	L			
L	H	L	L		L	H	-	-			
L	H	L	H		L	H	L	H			
L	L	L	H		-	-	L	H			
H	L	L	H		H	L	L	H			
H	H	*	*		H	H					
*	*	H	H				H	H			Brake
*	*	*	*	L					1.0V		
				H					0.67V		

:- Output OFF * : Don't care

For output "H", VC2×5.1 is output.

* All specs and applications shown above subject to change without prior notice.

(3) VCM constant-current control for SH/AE or stepping motor drive

Input					Output						Mode	
IN9	IN10	IN11	IN12	INHD	OUT9	OUT10	OUT11	OUT12	Vref	ISH		
L	L	L	L	L	-	-	-	-	-	-	Set voltage condition	Standby
H	L	*	*		H	L			1.0V	SH & AE		
L	H	*	*		L	H						
*	*	H	L				H	L				
*	*	L	H				L	H				
H	L	*	*	H	H	L			0.67V	Hole		
L	H	*	*		L	H						
*	*	H	L				H	L				
*	*	L	H				L	H				
L	L	L	L				-	-	-	-	Discharge	Standby

-: Output OFF *: Don't care

- OUT9 and 10 are for SH and have the stable start characteristics because of rapid charge and discharge circuits.
- OUT10 and 11 are for AE.
- At standby, the ISH pin voltage is put into the discharge condition by an internal transistor and set to 0 V.
- ISH pin is also in the discharge condition (for rise compensation) when IN1 - 8 are entered.
- The Vref voltage is 1.0 V with 1NHD = "L" and 0.67 V with 1NHD = "H."

8. Considerations for Design

(1) Constant-current setting (ISH, IAE, RFG1, 2, OUT9 to 12)

The constant current between OUT9 and OUT10 is set from the ISH input voltage and RFG1 connection resistance. Control is made so that the voltage generated at a current detection resistor connected between RFG1 and GND is equal to the ISH input voltage as shown in the block diagram. The output current is calculated as follows:

(Output current between OUT9 and OUT10) = (ISH input voltage)

* All specs and applications shown above subject to change without prior notice.

Lens Motor Driver for Digital Still Camera

(2) Rapid charge and discharge circuits (FC1, OUT9, OUT10)

SH control blocks (OUT9 - OUT10) incorporate rapid charge and discharge circuits to enable high-speed control of the shutter and a rapid discharge circuit to enable consecutive filming.

As these circuits are not built into AE control blocks (OUT11 to OUT12), use OUT9 and OUT10 blocks for shutter drive.

(3) Rise compensation function (ISH, OUT9, OUT10)

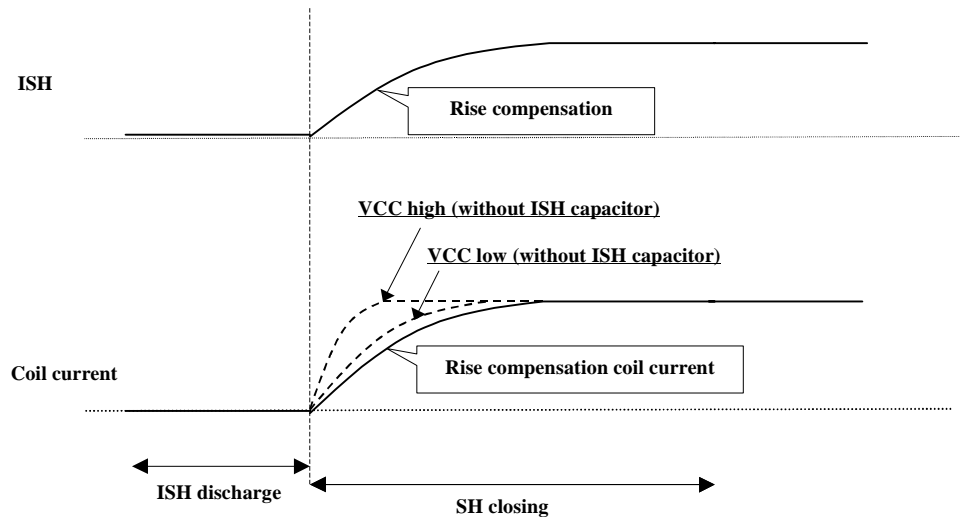

Setting the input voltage of ISH pin larger than the coil time constant by means of an external CR enables application of rise compensation to the coil waveform, ensuring stable shutter operation against fluctuation of power supply.

(Note) In ISH rise compensation, the rise waveform of coil current during VCC power reduction in the condition without ISH capacitor is checked. The capacity is determined so that the time constant becomes lower than this waveform. Note that the rise compensation capacitor is not necessary when the rise compensation function is not necessary, for example, when the stable supply voltage is supplied.

(4) Phase compensation capacitors (FC1, 2)

Set FC1 and 2 capacitors to the capacitance value within the range of 0.01 to 0.1 μ F that does not present an oscillation problem to the output. Particularly when a coil with high impedance is to be used, it is necessary to provide an allowance to the capacitance. As the constant-current control block is connected to PGND in IC, connect the GND side of FC1 and 2 capacitors to PGND.

(5) Constant-voltage control oscillation preventive capacitors (OUT1 to 8)

For constant-voltage control, it is necessary to insert a capacitor between OUT pins to prevent oscillation. Set the capacitor within a range of 0.01 μ F to 0.1 μ F that does not present an oscillation problem to the output. This oscillation preventive capacitor is not necessary when drive is made in the saturated condition.

(6) Capacitors for GND wiring and each power line (PGND, SGND, VCC, VB1, 1, VDD)

Connect PGND (two points) and SGND near IC and insert a capacitor directly near the power pin for each power supply.

* All specs and applications shown above subject to change without prior notice.

Lens Motor Driver for Digital Still Camera

(7) Input pin equivalent circuit

- IN1 to 12, INHD pins

- VC1, 2 pins

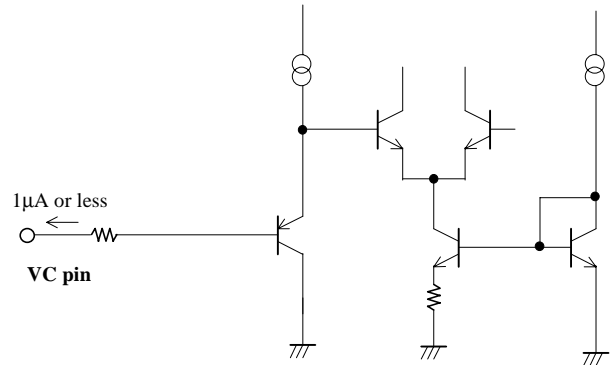
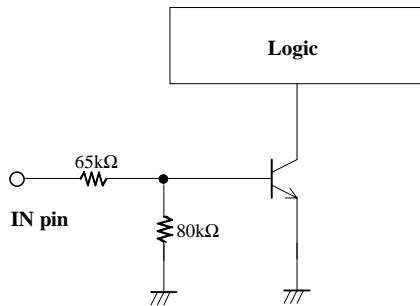

- IAE pin

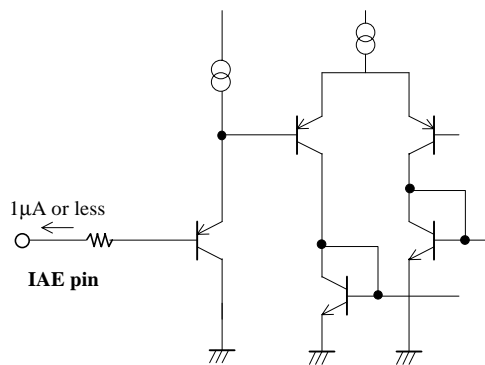

- ISH pin

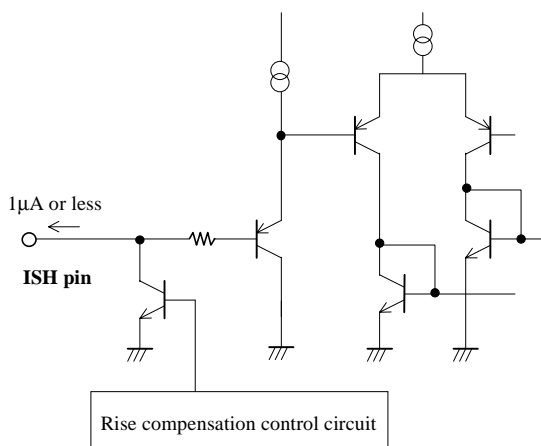

* All specs and applications shown above subject to change without prior notice.

Lens Motor Driver for Digital Still Camera

9. Internal Equivalent Circuit

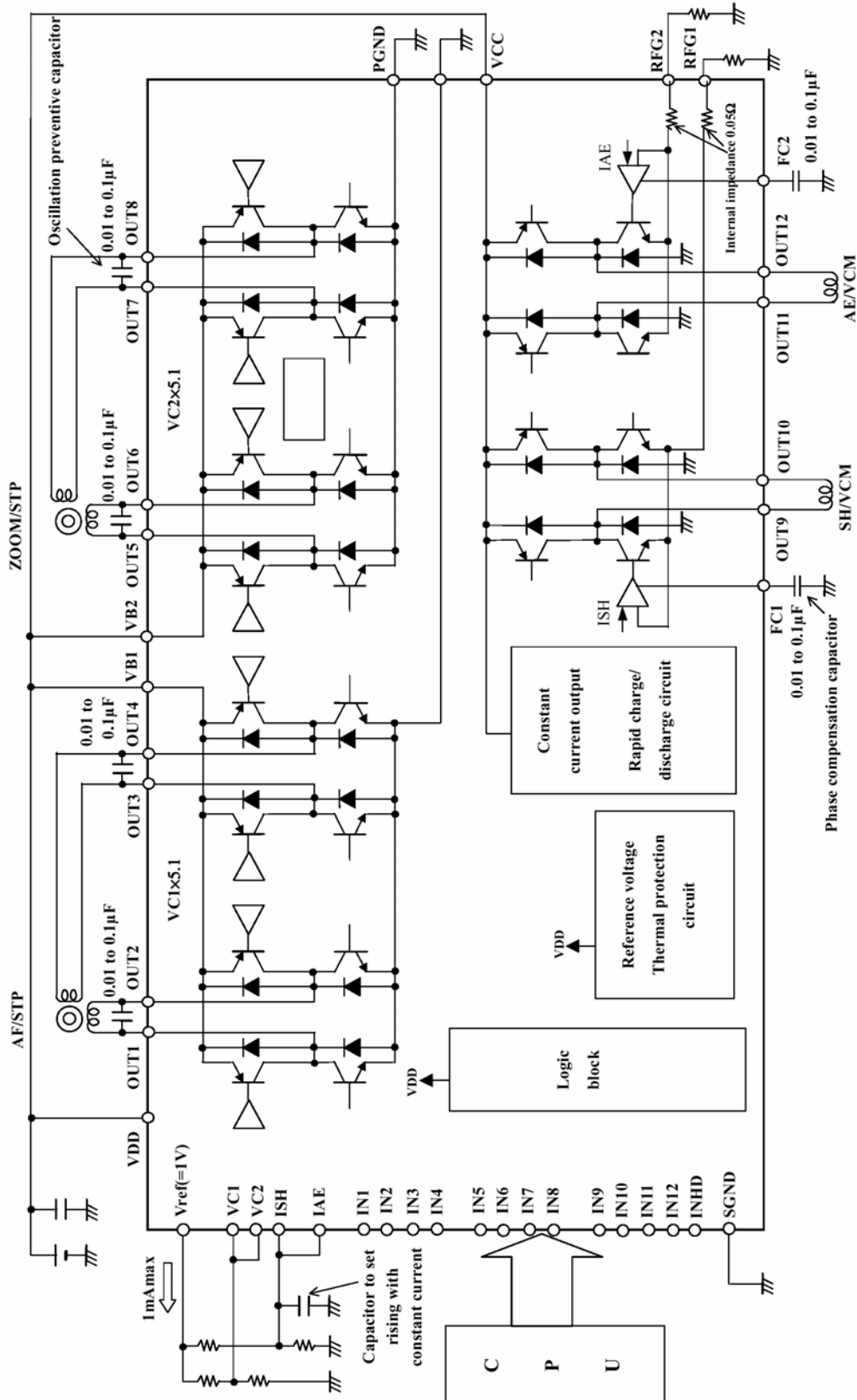

* All specs and applications shown above subject to change without prior notice.