

**SANYO Semiconductors**
**DATA SHEET**

# LA6565VR — Monolithic Linear IC Five-Channel CD Actuator Driver (BTL: 4 channels, H bridge: 1 channel)

## Overview

The LA6565VR is a four-channel BTL plus one-channel H bridge actuator driver developed for use in CD and DVD drives. The BTL driver channels 1 and 2 include built-in operational amplifiers allowing the LA6565VR to support a wide range of applications.

## Functions and Features

- Five power amplifier channels on a single chip (Bridge connection (BTL): 4 channels, H bridge: 1 channel)
- $I_O$  max: 1A
- Built-in level shifters (except for the H bridge channel)
- Muting circuits (output on/off, two systems)  
(The muting circuits operate for the BTL amplifiers. They do not apply to the H bridge or regulator circuits.)
- Built-in regulator (Uses an external PNP transistor and is set with an external resistor.)
- Output voltage setting function (loading driver)
- Built-in independent operational amplifiers
- Thermal shutdown circuit

## Specifications

Maximum Ratings at  $T_a = 25^\circ\text{C}$

Parameter	Symbol	Conditions	Ratings	Unit
Supply voltage	$V_{CC}$ max		14	V
Allowable power dissipation	$P_d$ max	Independent IC	0.55	W
		Mounted on a specified board	1.70	W
Maximum output current	$I_O$ max	For each of the channel 1 to 4 and H bridge outputs	1	A
Maximum input voltage	$V_{INB}$		13	V
MUTE pin voltage	$V_{MUTE}$		13	V
Operating temperature	$T_{opr}$		-30 to +85	$^\circ\text{C}$
Storage temperature	$T_{stg}$		-55 to +150	$^\circ\text{C}$

\* Mounted on a specified board: 76.1mm×114.3mm×1.6mm glass epoxy

- Any and all SANYO Semiconductor Co.,Ltd. products described or contained herein are, with regard to "standard application", intended for the use as general electronics equipment (home appliances, AV equipment, communication device, office equipment, industrial equipment etc.). The products mentioned herein shall not be intended for use for any "special application" (medical equipment whose purpose is to sustain life, aerospace instrument, nuclear control device, burning appliances, transportation machine, traffic signal system, safety equipment etc.) that shall require extremely high level of reliability and can directly threaten human lives in case of failure or malfunction of the product or may cause harm to human bodies, nor shall they grant any guarantee thereof. If you should intend to use our products for applications outside the standard applications of our customer who is considering such use and/or outside the scope of our intended standard applications, please consult with us prior to the intended use. If there is no consultation or inquiry before the intended use, our customer shall be solely responsible for the use.
- Specifications of any and all SANYO Semiconductor Co.,Ltd. products described or contained herein stipulate the performance, characteristics, and functions of the described products in the independent state, and are not guarantees of the performance, characteristics, and functions of the described products as mounted in the customer's products or equipment. To verify symptoms and states that cannot be evaluated in an independent device, the customer should always evaluate and test devices mounted in the customer's products or equipment.

**SANYO Semiconductor Co., Ltd.**

TOKYO OFFICE Tokyo Bldg., 1-10, 1 Chome, Ueno, Taito-ku, TOKYO, 110-8534 JAPAN

# LA6565VR

## Recommended Operating Conditions at $T_a = 25^\circ\text{C}$

Parameter	Symbol	Conditions	Ratings	Unit
Supply voltage	$V_{CC}$		5.6 to 13	V

## Electrical Characteristics at $T_a = 25^\circ\text{C}$ , $V_{CCS} = V_{CCP1} = V_{CCP2} = 8\text{V}$ , $V_{REF} = 2.5\text{V}$

Parameter	Symbol	Conditions	Ratings			Unit
			min	typ	max	
[Overall]						
Quiescent current when on	$I_{CC-ON}$	BTL amplifier output on, loading block off *1		30	50	mA
Quiescent current when off	$I_{CC-OFF}$	All outputs off *1		10	15	mA
Thermal shutdown circuit operating temperature	TSD	*7	150	175	200	$^\circ\text{C}$
[VREF Amplifier]						
VREF amplifier offset voltage	VREF- OFFSET		-10		10	mV
VREF input voltage range	VREF-IN		1		$V_{CC-1.5}$	V
VREF-OUT output current	I-VREF-OUT			1		mA
[Operational Amplifier] (Independent)						
Input voltage range	$V_{IN}$ (OP)		0		$V_{CC-1.5}$	V
Output current (sink)	SINK (OP)		2			mA
Output current (source)	SOURCE (OP)		300	500		$\mu\text{A}$
Output offset voltage	VOFF (OP)		-10		10	mV
Residual current (sink)	VCE-SINK (OP)	$I_O$ (sink side) = 1mA			0.6	V
[BTL Amplifier Block] (Channels 1 to 4)						
Output offset voltage	VOFF	The voltage difference between each channel outputs *2, *3	-50		50	mV
Input voltage range	$V_{IN}$	Input voltage range of the input operational amplifiers	0		$V_{CC-1.5}$	V
Output voltage	$V_O$	$I_O = 0.5\text{A}$ , the voltage between $V_{O+}$ and $V_{O-}$ in each channel	5.7	6.2		V
Closed circuit voltage gain	VG	The gain from the input to the output with the input amplifier set to 0dB *2, *3	7.2	8	9	times
Slew rate	SR	For the independent amplifier. Times 2 when between outputs *7		0.5		$\text{V}/\mu\text{s}$
Muting on voltage	VMUTE-ON	The output on voltage, for each mute function *4	2.5			V
Muting off voltage	VMUTE-OFF	The output off voltage, for each mute function *4			0.5	V
[Input Amplifier Block] (Channels 1 and 2)						
Input voltage range	$V_{IN-OP}$		0		$V_{CC-1.5}$	V
Output current (sink)	SINK-OP		2			mA
Output current (source)	SOURCE-OP	*5	300	500		$\mu\text{A}$
Output offset voltage	VOFF-OP		-10		10	mV
[Loading Block] (Channel 5, H bridge circuit)						
Output voltage	$V_{O-LOAD}$	For forward/reverse operation, $I_O = 0.5\text{A}$ , $V_{CONT} = V_{CC}^*$	5.7	6.5		V
Braking output saturation voltage	$V_{CE-BREAK}$	The output voltage during braking *6			0.3	V
Low-level input voltage	$V_{IN-L}$				1	V
High-level input voltage	$V_{IN-H}$		2			V

\*1: The total current dissipation for  $V_{CCP1}$ ,  $V_{CCP2}$ , and  $V_{CCS}$  with no load.

\*2: The input amplifier is a buffer amplifier.

\*3: The voltage difference between the two sides of the load (12 $\Omega$ ).

\*4: When the MUTE pin is high, the output will be on, and when low, the output will be off (high-impedance state).

\*5: The input operational amplifier source is constant current. Since the 11k $\Omega$  resistor between this and the next stage functions as the load, the input operational amplifier gain must be set carefully.

\*6: The braking operation is a short (to ground) braking operation. The sink side output is on at this time.

\*7: Design guarantee.

Continued on next page.

# LA6565VR

Continued from preceding page.

Parameter	Symbol	Conditions	Ratings			Unit
			min	typ	max	
[Power Supply Block] (Uses an external 2SB632K PNP transistor)						
Power supply output	$V_{OUT}$	$I_O = 200\text{mA}$	1.260	1.285	1.310	V
REG-IN sink current	REG-IN-SINK	External PNP transistor base current	5	10		mA
Line regulation	$\Delta V_{OLN}$	$6\text{V} \leq V_{CC} \leq 12\text{V}$ , $I_O = 200\text{mA}$		10	100	mV
Load regulation	$\Delta V_{OLD}$	$5\text{mA} \leq I_O \leq 200\text{mA}$		10	100	mV

## Package Dimensions

unit : mm (typ)

3344

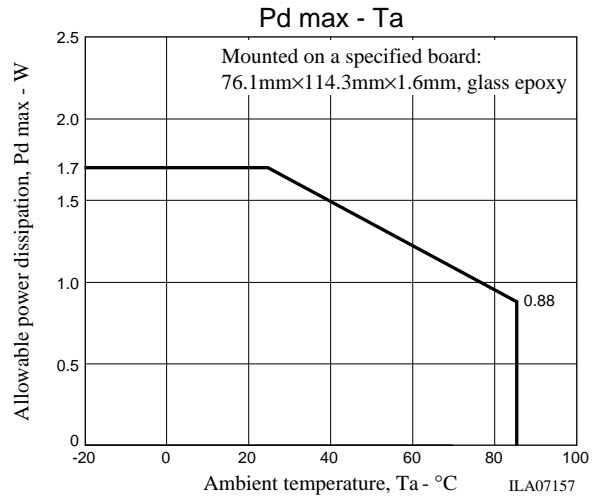
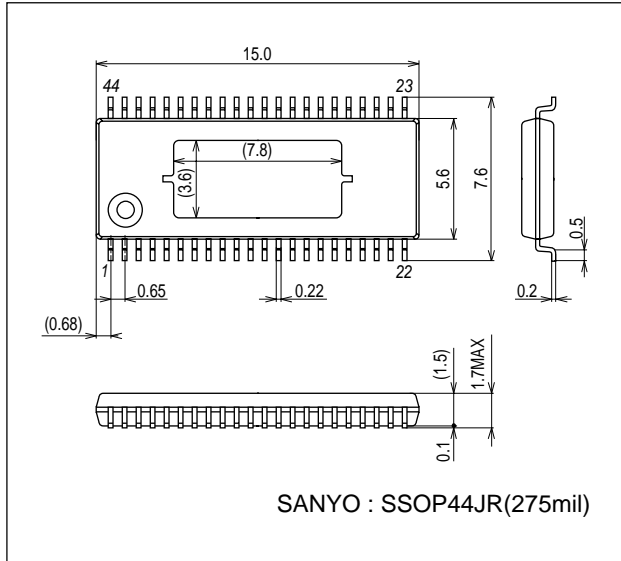

# LA6565VR

## Pin Functions

Pin No.	Pin Name	Description
1	FWD	LOADING output changeover pin (FWD), LOADING logic input
2	REV	LOADING output changeover pin (REV), LOADING logic input
3	V <sub>CC2</sub>	LOADING power-stage power supply for channel 3 and 4
4	NC	-
5	VLO <sup>-</sup>	Loading output (-)
6	VLO <sup>+</sup>	Loading output (+)
7	V <sub>O4</sub> <sup>+</sup>	Output pin (+) for channel 4
8	V <sub>O4</sub> <sup>-</sup>	Output pin (-) for channel 4
9	V <sub>O3</sub> <sup>+</sup>	Output pin (+) for channel 3
10	V <sub>O3</sub> <sup>-</sup>	Output pin (-) for channel 3
11	PGND2	Power system GND
12	PGND1	Power system GND
13	V <sub>O2</sub> <sup>+</sup>	Output pin (+) for channel 2
14	V <sub>O2</sub> <sup>-</sup>	Output pin (-) for channel 2
15	V <sub>O1</sub> <sup>-</sup>	Output pin (+) for channel 1
16	V <sub>O1</sub> <sup>+</sup>	Output pin (-) for channel 1
17	NC	-
18	V <sub>CCP1</sub>	Power-stage power supply for channel 1 and 2
19	V <sub>CCS</sub>	Signal system power supply
20	V <sub>IN1</sub> <sup>+</sup>	Input pin for channel 1, Input OP-AMP (+) input
21	V <sub>IN1</sub> <sup>-</sup>	Input pin for channel 1, Input OP-AMP (-) input
22	V <sub>IN1</sub>	Input pin for channel 1, Input OP-AMP output
23	NC	-
24	V <sub>IN2</sub> <sup>+</sup>	Input pin for channel 2, Input OP-AMP (+) input
25	V <sub>IN2</sub> <sup>-</sup>	Input pin for channel 2, Input OP-AMP (-) input
26	V <sub>IN2</sub>	Input pin for channel 2, Input OP-AMP output
27	NC	-
28	V <sub>IN3</sub> <sup>-</sup>	Input pin for channel 3, Input OP-AMP (-) input
29	V <sub>IN3</sub>	Input pin for channel 3, Input OP-AMP output
30	V <sub>O</sub> _OP	OP-AMP, output pin
31	V <sub>IN</sub> <sup>-</sup> OP	OP-AMP, (-) input pin
32	V <sub>IN</sub> <sup>+</sup> OP	OP-AMP, (+) input pin
33	REG_IN	Regulator, error AMP output pin. Base to external PNP transistor connected
34	NC	-
35	REG_OUT	Regulator, error AMP input pin (+)
36	VREF_OUT	VREF_AMP (voltage follower) output pin
37	VREF_IN	VREF input pin. Input the external reference voltage
38	V <sub>IN4</sub>	Input pin for channel 4, Input OP-AMP output
39	NC	-
40	V <sub>IN4</sub> <sup>-</sup>	Input pin for channel 4, Input OP-AMP (-) input
41	MUTE234	Output ON/OFF pin for channel 2, 3 and 4
42	MUTE1	Output ON/OFF pin for channel 1
43	VCONT	LOADING output (H voltage) setting pin
44	S_GND	Signal system GND

# LA6565VR

## Pin Description

Pin No.	Pin Name	Pin Name	Description	Equivalent Circuit Diagram Description
20 21 22 24 25 26 28 29 38 40 32 31 30	$V_{IN1+}$ $V_{IN1-}$ $V_{IN1}$ $V_{IN2+}$ $V_{IN2-}$ $V_{IN2}$ $V_{IN3+}$ $V_{IN3-}$ $V_{IN3}$ $V_{IN4+}$ $V_{IN4-}$ $V_{IN4}$ $V_{IN+OP}$ $V_{IN-OP}$ $V_{O\_OP}$	Input (CH1 to 4)	Inputs (channels 1 to 4 and the independent operational amplifier)	
1 2	FWD REV	Input (H bridge)	Logic inputs The IC is set to one of four modes, forward, reverse, brake, and free running by the combination of high and low values applied to these pins.	
16 15 13 14 9 10 7 8	$V_{O1+}$ $V_{O1-}$ $V_{O2+}$ $V_{O2-}$ $V_{O3+}$ $V_{O3-}$ $V_{O4+}$ $V_{O4-}$	Output (BTL-AMP)	Channel 1 to 4 outputs	
5 6 43	$V_{LO-}$ $V_{LO+}$ VCONT	Output (H bridge)	H bridge (loading) output and loading output setting	
41 42	MUTE234 MUTE1	MUTE	BTL amplifier output on/off state setting. High: output on Low: output off	

**Truth Table (Loading (H bridge) block)**

FWD	REV	VLO+	VLO-	Loading output
L	L	OFF	OFF	OFF *1
	H	H	L	Forward
H	L	L	H	Reverse
	H	L	L	Short-circuit braking *2

\*1. The output goes to the high-impedance state.

\*2. In braking mode, the sink side transistor is turned on (for short-circuit braking).

The VLO+ and VLO- pins go to a level that is essentially the ground level.

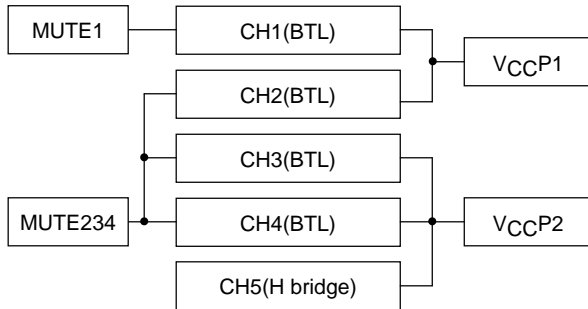
**Relationship Between The MUTE Pins and The Power Supply Systems (VCCP\*)**

# LA6565VR

## Internal Block Diagram

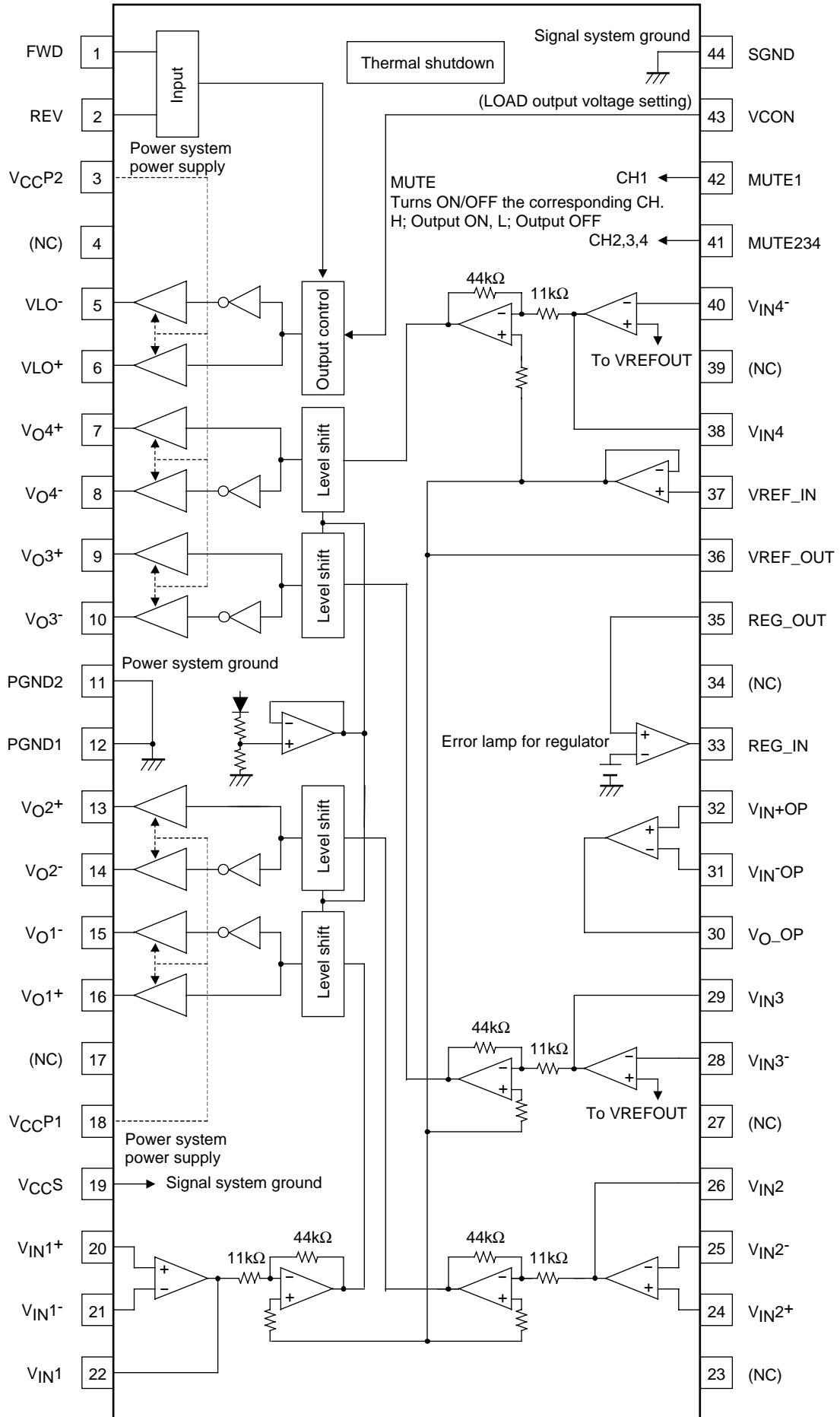

# LA6565VR

## Sample Application Circuit

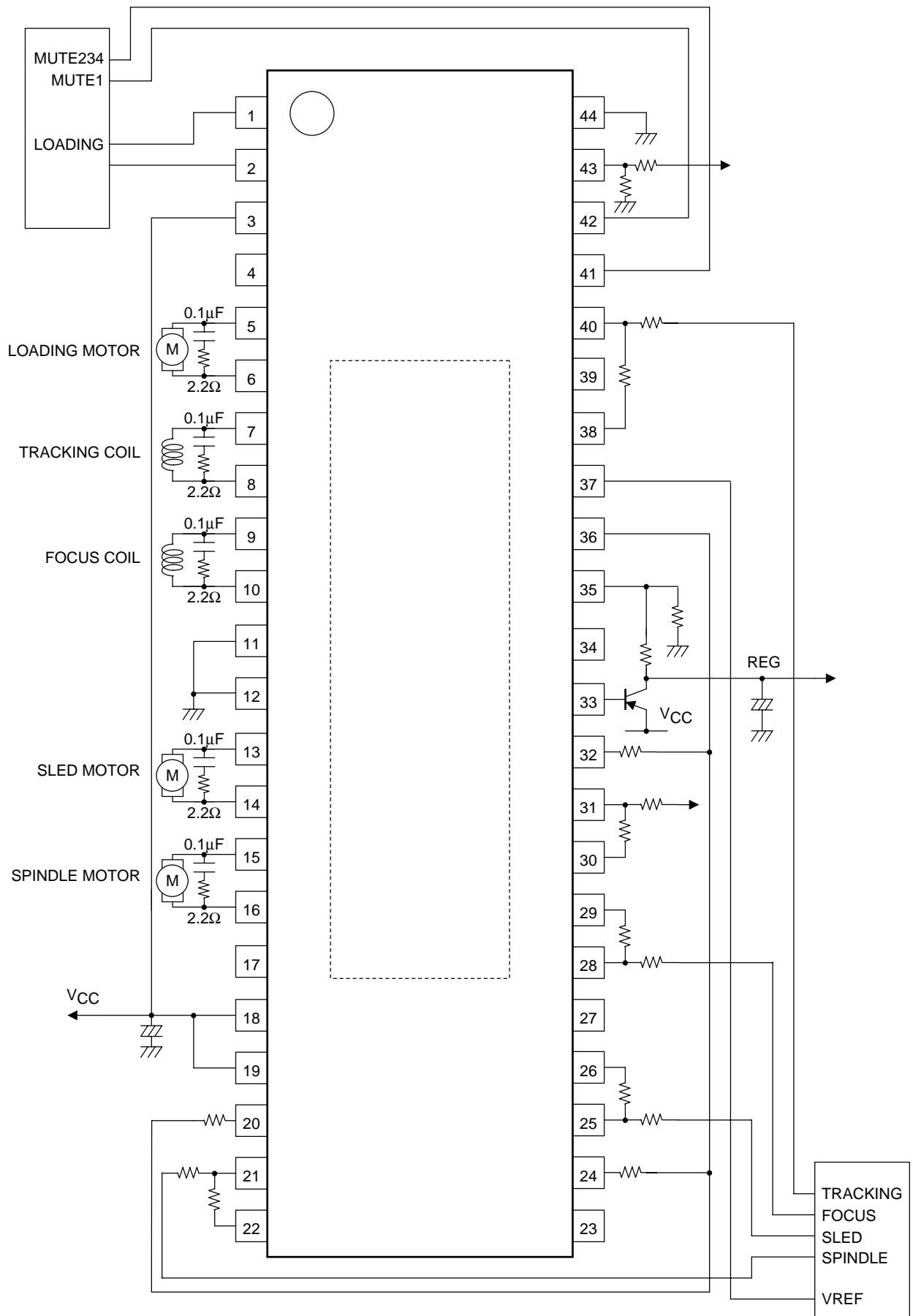



- SANYO Semiconductor Co.,Ltd. assumes no responsibility for equipment failures that result from using products at values that exceed, even momentarily, rated values (such as maximum ratings, operating condition ranges, or other parameters) listed in products specifications of any and all SANYO Semiconductor Co.,Ltd. products described or contained herein.
- SANYO Semiconductor Co.,Ltd. strives to supply high-quality high-reliability products, however, any and all semiconductor products fail or malfunction with some probability. It is possible that these probabilistic failures or malfunction could give rise to accidents or events that could endanger human lives, trouble that could give rise to smoke or fire, or accidents that could cause damage to other property. When designing equipment, adopt safety measures so that these kinds of accidents or events cannot occur. Such measures include but are not limited to protective circuits and error prevention circuits for safe design, redundant design, and structural design.
- In the event that any or all SANYO Semiconductor Co.,Ltd. products described or contained herein are controlled under any of applicable local export control laws and regulations, such products may require the export license from the authorities concerned in accordance with the above law.
- No part of this publication may be reproduced or transmitted in any form or by any means, electronic or mechanical, including photocopying and recording, or any information storage or retrieval system, or otherwise, without the prior written consent of SANYO Semiconductor Co.,Ltd.
- Any and all information described or contained herein are subject to change without notice due to product/technology improvement, etc. When designing equipment, refer to the "Delivery Specification" for the SANYO Semiconductor Co.,Ltd. product that you intend to use.
- Information (including circuit diagrams and circuit parameters) herein is for example only; it is not guaranteed for volume production.
- Upon using the technical information or products described herein, neither warranty nor license shall be granted with regard to intellectual property rights or any other rights of SANYO Semiconductor Co.,Ltd. or any third party. SANYO Semiconductor Co.,Ltd. shall not be liable for any claim or suits with regard to a third party's intellectual property rights which has resulted from the use of the technical information and products mentioned above.

This catalog provides information as of April, 2007. Specifications and information herein are subject to change without notice.