

Compander IC Monolithic IC MM1077

Outline

This IC was developed for use in cordless telephone equipment. It is a compander IC incorporating compressor/expander circuits for a significant noise reduction effect without complicated external circuitry. On the transmission side, the dynamic range of audio signals is compressed by the compressor circuit; on the receiving side, the expander expands the signals. As a result the dynamic range over the transmission channel is reduced logarithmically by one-half.

Features

1. Can be driven at low voltages (down to 2.0V)
2. Internal mute function
3. Internal limiter (IDC) function
4. Compressor input can be switched between MIC and LINE
5. Internal standby function
6. Data input, output pins
7. Independent mute circuit

Package

SSOP-24A (MM1077XF)

Applications

1. Cordless telephones
2. Various mobile communication devices

Pin Assignment

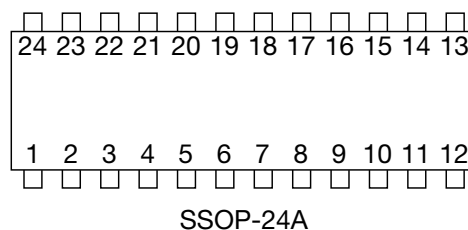

1	C.Vref	9	DATA. IN	17	E.RECT
2	C.IN1	10	C.CONT	18	E.OUT
3	C.IN2	11	N.C	19	E.RIN
4	C.IN-	12	GND	20	A.OUT
5	C.RECT	13	STANDBY SW	21	A.IN-
6	C.RIN	14	C.IN SW	22	A.IN+
7	C.FB	15	C.MUTE SW	23	E.Vref
8	C.NF	16	E.MUTE SW	24	Vcc

Block Diagram

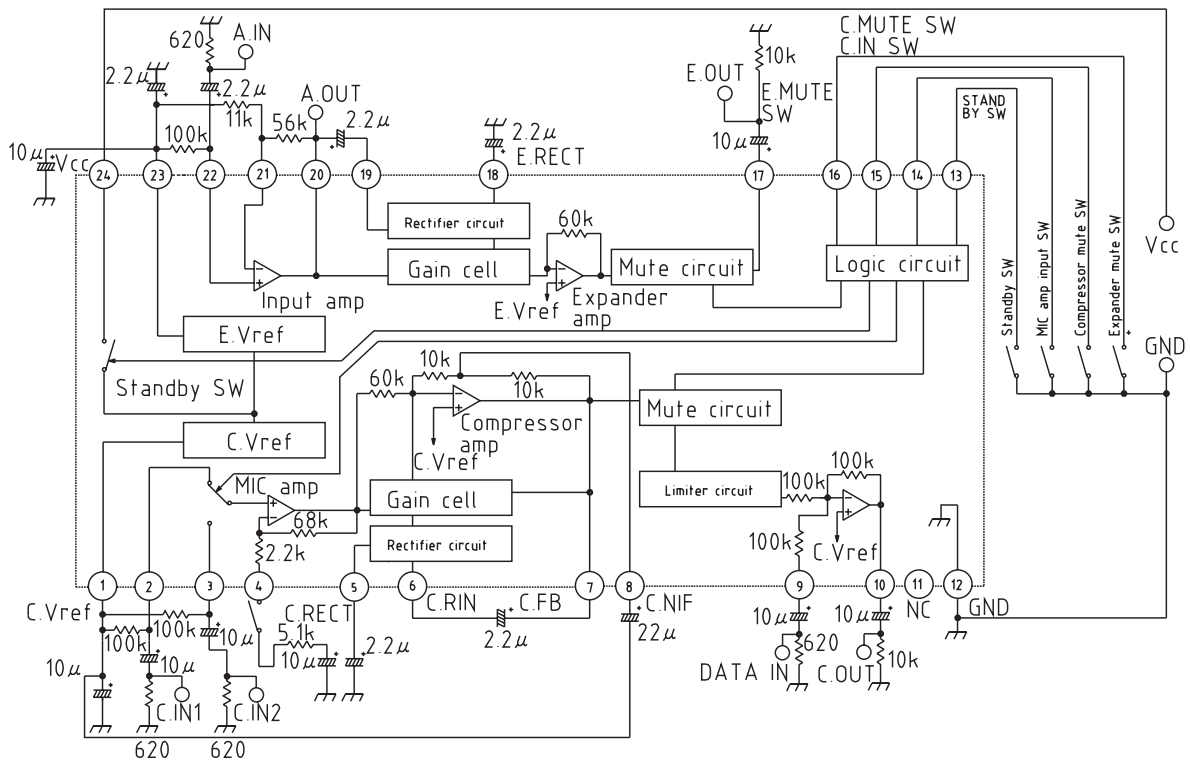

Absolute Maximum Ratings (Ta=25°C)

Item	Symbol	Ratings	Units
Storage temperature	T _{STG}	-40~+125	°C
Operating temperature	T _{OPR}	-10~+70	°C
Power supply voltage	V _{CC max.}	-0.3~+8	V
Allowable loss	P _d	650	mW
Operating voltage		+2.0~+7	V

Electrical Characteristics (Except where noted otherwise, Ta=25°C, Vcc=3V, fin=1kHz)

	Item	Symbol	Measurement conditions	Min.	Typ.	Max.	Units
	Consumption current	I _{CC}	No signal		4.0	6.0	mA
	Standby current consumption	I _{SCC}			0	10	μA
	Threshold voltage	V _{th}		0.40	0.65	0.80	V
Compressor unit	Input reference level	V _{INC}	V _{oc} =100mVrms, V _{IN} =0dB	8.0	13.5	18.0	mVrms
	Gain error *	G _{c1}	V _{IN} =-20dB	-0.5	0	0.5	dB
		G _{c2}	V _{IN} =-40dB	-1.0	0	1.0	dB
	Distortion	THD _c	V _{IN} =0dB		0.3	1.0	%
	Output noise voltage	V _{nc}	No signal (CCITT)		2.5	5.0	mVrms
	Mute attenuation	Att _c	V _{IN} =0dB, C.MUTE SW : ON	40	50		dB
	Limit voltage	V _{limc}	THD=10%	700	800	900	mV _{p-p}
	DATA pin voltage gain	G _{DATA}	C. MUTE SW : ON, V _{IN} =0dB	-0.5	0	0.5	dB
	DATA pin maximum output	V _{D max.}	C.MUTE SW : ON, THD=10%	800	900		mVrms
	Crosstalk	CT _c	EXPV _{IN} =0dB	28	33		dB
Ripple rejection ratio	RR _c	V _R =100mVrms, f _R =1kHz	18	23		dB	
Expander unit	Input reference level	V _{INE}	V _{oe} =100mVrms, V _{IN} =0dB	25	35	50	mVrms
	Gain error difference *	Ge ₁	V _{IN} =-10dB	-0.5	0	0.5	dB
		Ge ₂	V _{IN} =-20dB	-1.0	0	1.0	dB
		Ge ₃	V _{IN} =-30dB	-1.5	0	1.5	dB
	Distortion	THD _e	V _{IN} =0dB		0.15	1.0	%
	Maximum output voltage	V _{e max.}	THD=10%	600	800		mVrms
	Output noise voltage	V _{ne}	No signal (CCITT)		20	40	μVrms
	Mute attenuation	Att _e	V _{IN} =0dB, C. MUTE SW : ON	60	70		dB
	Input amp voltage gain	G _I	V _{IN} =0dB	14.6	15.6	16.6	dB
Input amp maximum output	V _{eo max.}	THD=10%	0.90	1.10		Vrms	
Crosstalk	CT _e	COMPV _{IN} =0dB	60	75		dB	
Ripple rejection ratio	RR _e	V _R =100mVrms, f _R =1kHz	50	60		dB	

*Gain error difference = (V_{OUT} (dBv)+20dB) - V_{IN} (dB) × G (dB)
 G : COMP=0.5, EXP=2

Function Description

1. Compressor unit

The compressor unit consists of the mike amp, compressor, limiter circuit, data amp, and mute circuit. The mike amp gain can be adjusted through an external resistance, and so the mike amp can be connected directly to a microphone. An internal limiter circuit to prevent overmodulation as well as a data amp (0dB amp) enabling transmission of data signals without compression are also provided. Switching between audio signals and data signals is possible using the compressor mute switch.

2. Expander unit

The expander unit consists of an input amp, expander, and mute circuit. The input amp makes available all input and output signals at pins, and so can be used freely as an amplifier, filter amp, or data amp. When used as a data amp, the expander mute switch can be set so that the expander output is nearly silent.

About Application Circuits

1. Mike amp

The compressor unit mike amp is exposed to circuits outside the IC via positive and negative input pins. The positive input pin is connected to C.Vref by a bias resistance of 100kΩ, so that no external bias is needed.

When pin 4 is open the gain is lowest, and an input voltage of approx. 13.5Vrms is the reference level. When the external resistance is 0Ω, the gain is maximum. The internal configuration appears in Fig. 1.

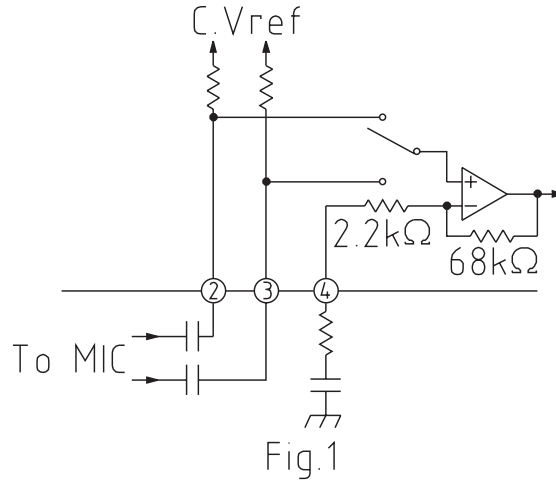

Fig.1

2. Rectifier circuit unit (rectifier)

The product of the external capacitance and the internal resistance (10kΩ) determines the time constants for the attack and release times.

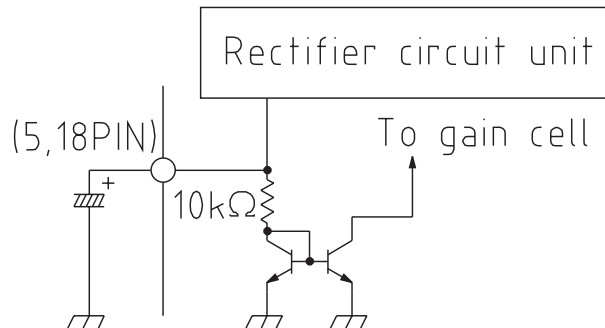

Fig.2

3. Compressor amp

The compressor amp requires that the DC gain be unity and the AC gain be infinite. In order to satisfy this requirement, AC feedback is eliminated and only DC feedback is used. In order that only DC feedback be present, a capacitor to eliminate AC components is connected to pin 8. The cutoff frequency is determined by the product with the internal resistance (100kΩ).

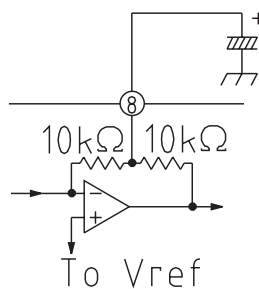

Fig.3

4. Compressor data amp

The data amp uses an inverting amp. The internal input resistance is 100kΩ, and the DC bias voltage is 1.3V. The compressor mute switch at pin 15 is used to switch between data signals and audio signals.

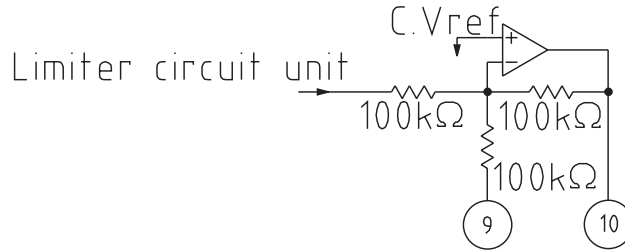

Fig.4

5. Expander input amp

The positive and negative input pins and the output pin are exposed to circuitry outside the IC. The expander input amp can be used as a signal amplifier, a buffer amplifier, and a filter amp. By taking the signal from this amp's output pin, the data signal can be obtained without passing through the expander. If the expander mute switch is turned on, this signal can be prevented from appearing in the expander output.

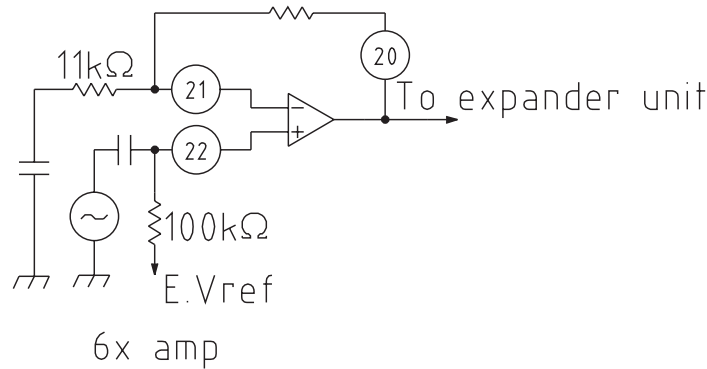

Fig.5

6. Mike amp input switch and mute switches

The internal equivalent circuit for each of these switches appears in Fig. 6.

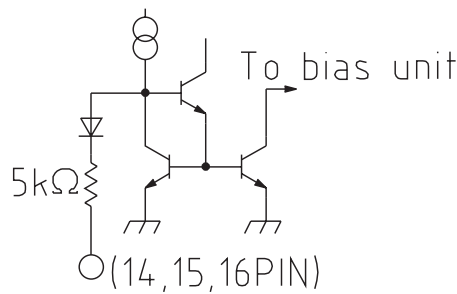

Fig.6

7. Standby switch

The internal equivalent circuit for the standby switch appears in Fig. 7.

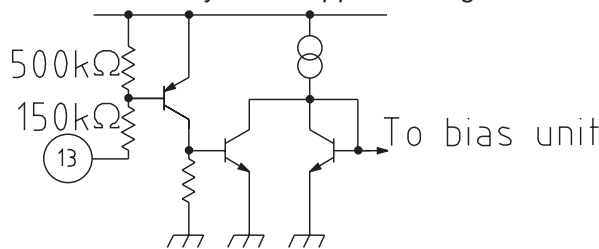
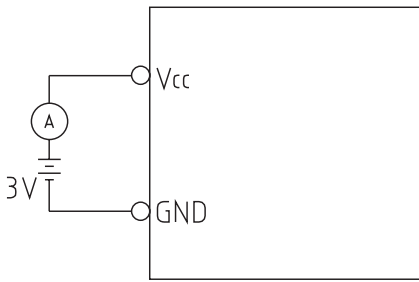

Fig.7

Measuring Circuit (Except where noted otherwise, $f_{IN}=1\text{kHz}$)

1. Consumption current



5. Distortion

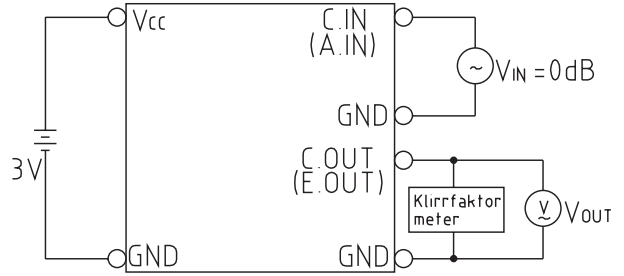

2. Threshold voltage

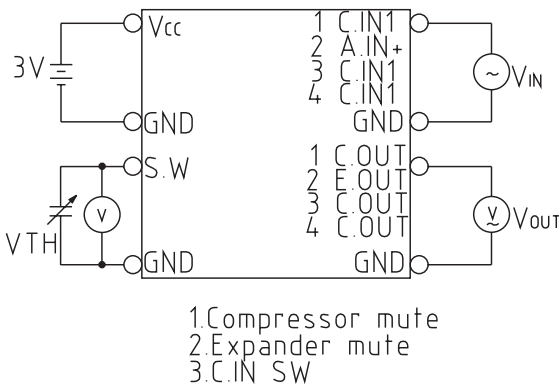

6. Limit voltage

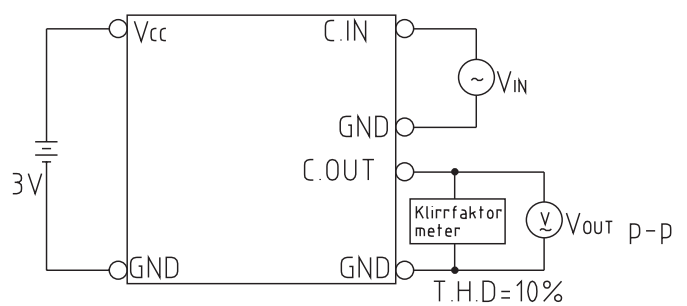

3. Input reference level

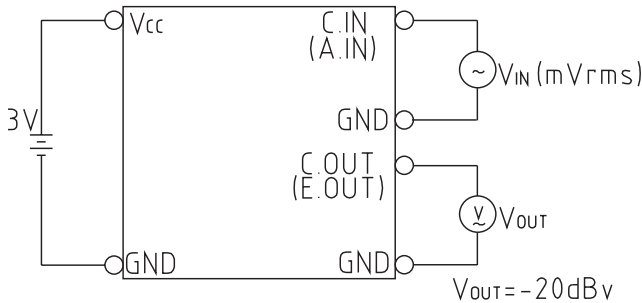

7. Maximum output voltage

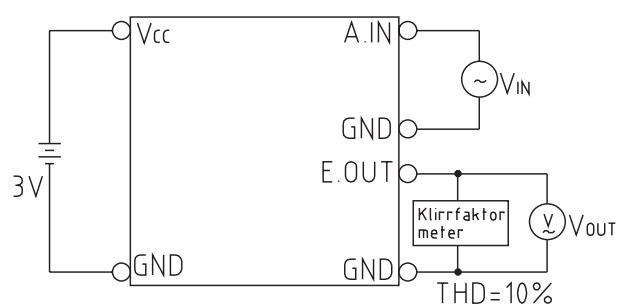

4. Gain error difference

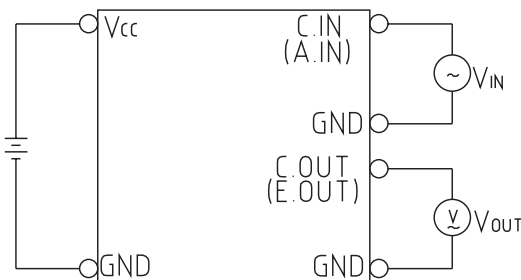

Gain error difference = $(V_{OUT} \text{ (dBv)} - 20\text{dB}) - V_{IN} \text{ (dB)} \times G$
 $(G = \text{COMP} = 0.5, \text{EXP} = 2)$

Gain error difference (1) $G_{c1} = -20\text{dB}, G_{e1} = -10\text{dB}$

Gain error difference (2) $G_{c2} = -40\text{dB}, G_{e2} = -20\text{dB}$

Gain error difference (3) $G_{e3} = -30\text{dB}$

8. DATA pin/Input amp voltage gain

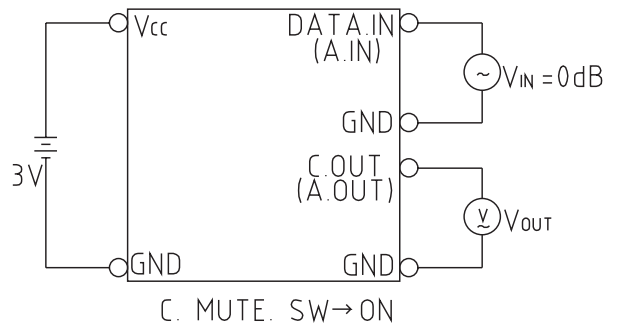

9. DATA pin/Input amp maximum output

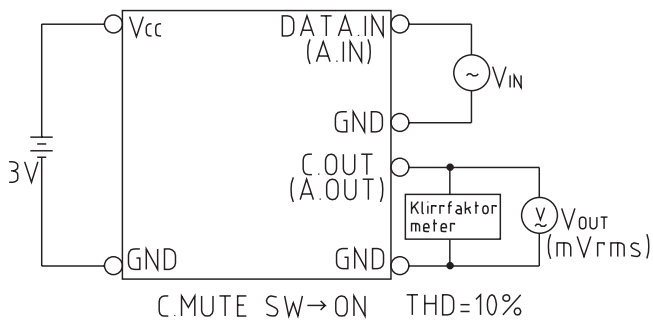

10. Crosstalk

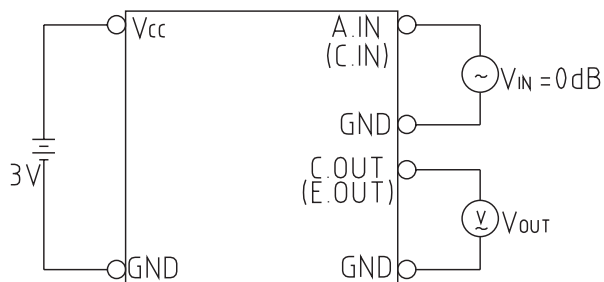

11. Ripple rejection

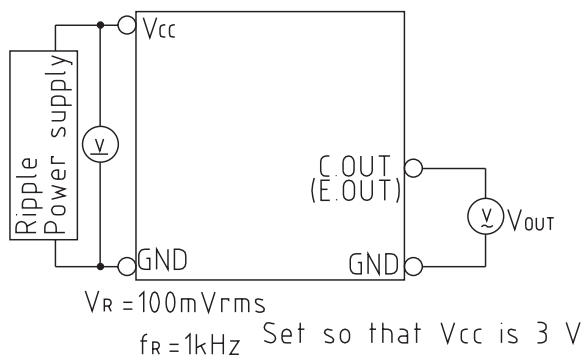

12. Output noise voltage

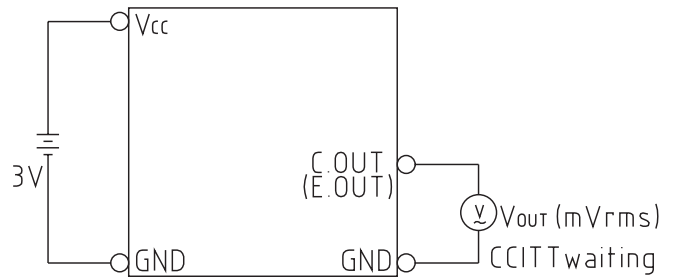

13. Mute attenuation

