

1.0 General Description

The AMIS-74980x is a wide dynamic range family of ambient light sensors (ALS) with an analog or digital output. There are several versions of the ALS with analog output; one with 10uA current output at 1000lux all the way to 1mA at 1000lux. The digital output version has a built-in 16-bit ADC with a 2-wire SMBus or I²C digital interface. The sensor employs AMI Semiconductor's proprietary CMOS image sensing technology which provides low noise and high dynamic range output signals and a light response similar to the response of the human eye.

This data sheet provides details of the DC characteristics, AC characteristics and programming information of AMIS-749803 (I²C) ALS.

2.0 Key Features

- Senses ambient light and provides an output count proportional to the ambient light
- Human eye type of spectral response
- Standard CMOS process technology
- Low power consumption
- Linear response over the full operating range
- Senses intensity of ambient light from ~0lux to well over 100,000lux
- Built-in programmable integration times of 400ms, 200ms and 100ms
- Does not require any external components
- Built-in 16-bit ADC
- I²C serial port communication
 - Standard mode – 100kHz
 - Fast mode – 400kHz
- Provides comfortable levels of display depending on the viewing environment

Saves display power in applications such as:

- Cell phone
- PDA
- MP3 player
- GPS
- Video recorder

3.0 Pin Out

Table 1: Pin Out

Pin Name	Pin No.	I, O or IO	Function	Comments
I2CCLK	3	I	This is the external I2C clock that is provided by the I2C master	
I2CDATA	4	IO	This bi-directional data signal is used for communication between this device and the I2C master	
VDD	5	I	This pin is the power pin	
VSS	1	I	This pin is the GND pin	

4.0 Spectral Response

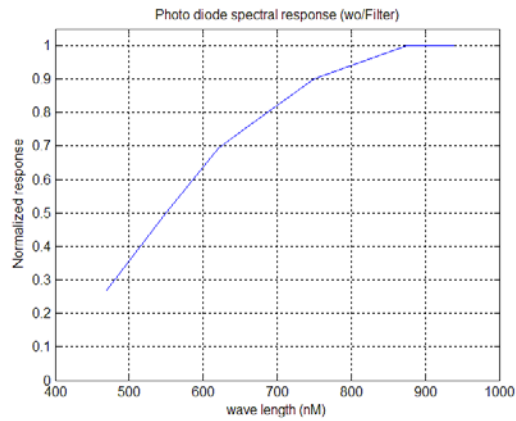

Figure 1: Photo Diode Spectral Response (Without Filter)

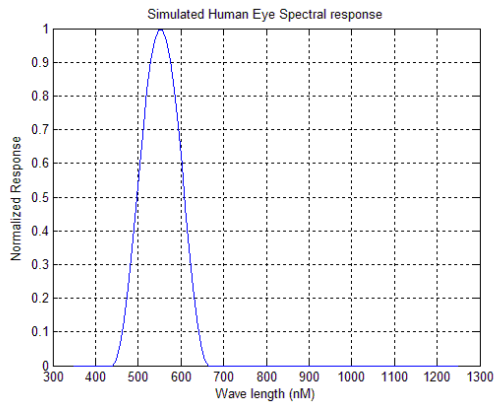

Figure 2: Simulated Human Eye Spectral Response

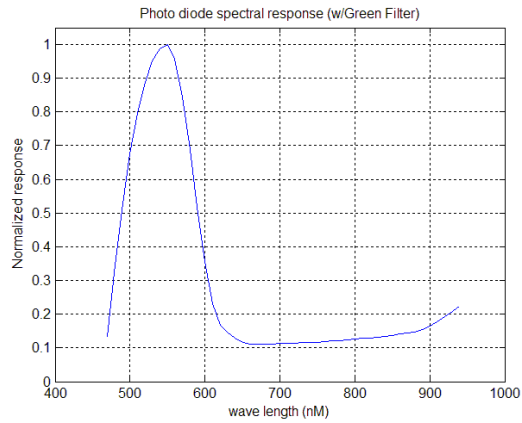

Figure 3: Photo Diode Spectral Response (With Green Filter)

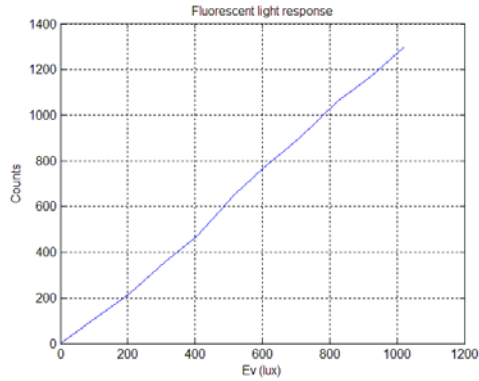

Figure 4: Fluorescent Light Response

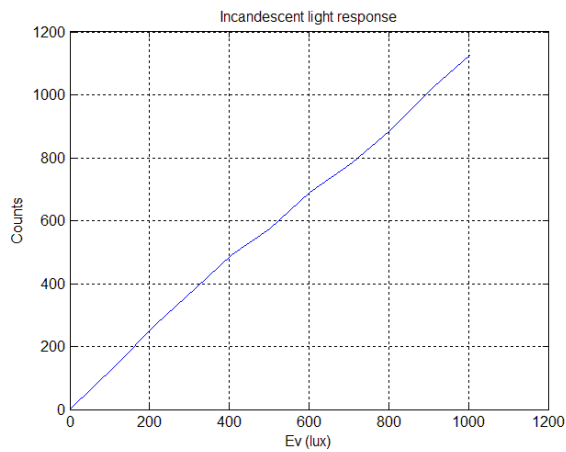

Figure 5: Incandescent Light Response



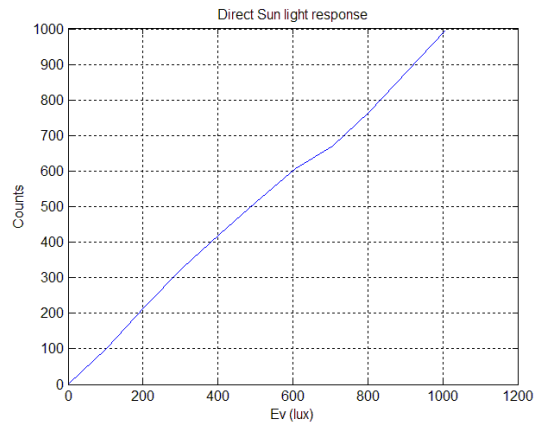

Figure 6: Direct Sunlight Response

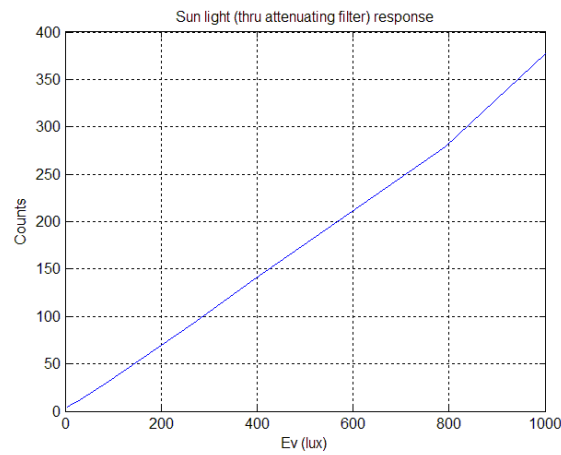

Figure 7: Sunlight Response (Through Attenuating Filter)

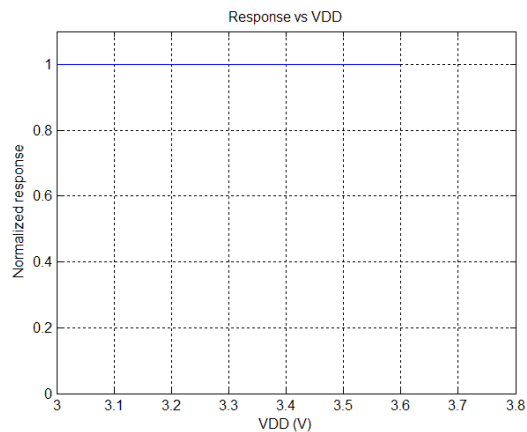

Figure 8: Response versus VDD

5.0 Absolute Maximum Ratings

Over operating free-air temperature range (unless otherwise noted)

Stresses beyond those listed under “absolute maximum ratings” may cause permanent damage to the device. These are stress ratings only and functional operation of the device at these conditions is not recommended. Exposure to absolute maximum rated conditions for extended periods may affect device reliability.

- Supply voltage, VDD 4V
- Input voltage high..... VDD + 0.3V
- Input voltage low..... -0.3V
- Digital output current, I_O..... ±10mA
- Operating free-air temperature range, T_A 0°C to 70°C
- Storage temperature range, T_{stg}..... -40°C to 85°C
- ESD tolerance, human body model..... 2000V

Note:
All voltages are with respect to VSS.

6.0 Electrical Characteristics

Table 2: DC Characteristics of I2CCLK and I2CDATA Signals in Standard and Fast Modes of Operation

Parameter	Symbol	Standard Mode		Fast Mode		Unit
		Min.	Max.	Min.	Max.	
Power supply voltage (current version)	VDD	3.0	3.6	3.0	3.6	V
Operating free-air temperature	T _A	0	70	0	70	°C
Low level input voltage (VDD-related input levels)	V _{IL}	-0.5	0.3VDD	-0.5	0.3VDD	V
High level input voltage (VDD-related input levels)	V _{IH}	0.7VDD		0.7VDD		V
Hysteresis of Schmitt trigger inputs (VDD > 2V)	V _{hys}	N/A	N/A	0.05VDD	-	V
Low level output voltage (open drain) at 3mA sink current (VDD > 2V)	V _{OL1}	0	0.4	0	0.4	V
Output fall time from V _{IHmin} to V _{ILmax} with a bus capacitance from 10pF to 400pF	t _{of}	-	250 ⁽²⁾	20 + 0.1Cb ⁽¹⁾	250 ⁽²⁾	nS
Input current of each IO pins with an input voltage between 0.1VDD and 0.9VDD	I _i	-10	10	-10	10	uA
Capacitance for each IO pin	C _i	-	10	-	10	pF

- Notes:
1. Cb = capacitance of one bus line in pF.
 2. The maximum t_f for the I2CDATA and I2CCLK bus lines quoted in Table 3 (300ns) is longer than the specified maximum t_{of} for the output stages (250ns). This allows series protection resistors (Rs) to be connected between the I2CDATA/I2CCLK pins and the I2CDATA/I2CCLK bus lines without exceeding the maximum specified t_f.

Table 3: AC Characteristics of I2CCLK and I2CDATA Signals in Standard and Fast Modes of Operation*

Parameter	Symbol	Standard Mode		Fast Mode		Unit
		Min.	Max.	Min.	Max.	
I2CCLK clock frequency	f_{SCL}	0	100	0	400	kHz
Hold time (repeated) START condition. After this period, the first clock pulse is generated	$t_{HD;STA}$	4.0	-	0.6	-	μ S
Low period of I2CCLK clock	t_{LOW}	4.7	-	1.3	-	μ S
High period of I2CCLK clock	t_{HIGH}	4.0	-	0.6	-	μ S
Set-up time for a repeated START condition	$t_{SU;STA}$	4.7	-	0.6	-	μ S
Data hold time for I2C-bus devices	$t_{HD;DAT d}$	0	3.45	0	0.9	μ S
Data set-up time	$t_{SU;DAT}$	250	-	100	-	nS
Rise time of both I2CDATA and I2CCLK signals	t_r	-	1000	5	300	nS
Fall time of both I2CDATA and I2CCLK signals	t_f	-	300	0.1	300	nS
Set-up time for STOP condition	$t_{SU;STO}$	4.0	-	0.6	-	μ S
Bus free time between STOP and START condition	t_{BUF}	4.7	-	1.3	-	μ S
Capacitive load for each bus line	C_b	-	400	-	400	pF
Noise margin at the low level for each connected device (including hysteresis)	V_{nL}	0.1VDD	-	0.1VDD	-	V
Noise margin at the high level for each connected device (including hysteresis)	V_{nH}	0.2VDD	-	0.2VDD	-	V

*All values referred to V_{IHmin} and V_{ILmax} levels (see Table 2). Please refer to Figure 9 for more information on AC characteristics.

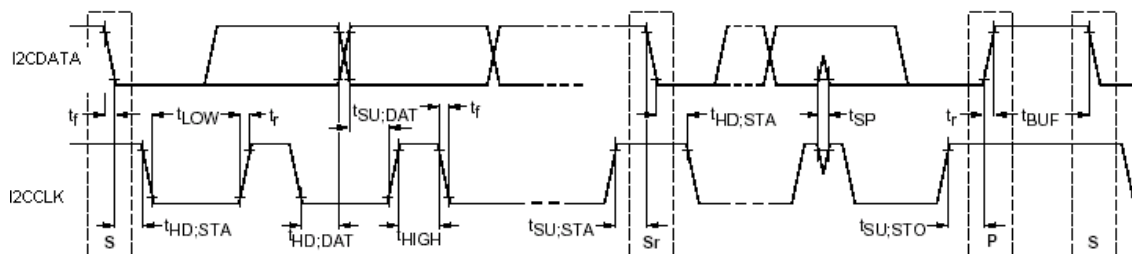

Figure 9: AC Characteristics

Table 4: Operating Characteristics, V_{DD} = 3.3V, T_A = 25°C (unless otherwise noted)

Parameter	Test Conditions	Min.	Typ.	Max.	Units
R _e irradiance responsivity	λ _p (see Figure 3)		550		nM
R _v illuminance responsivity	Fluorescent light source: Ev = 100lux (see Figure 4)		109		Counts
	Fluorescent light source: Ev = 1000lux (see Figure 4)		1275		
R _v illuminance responsivity	Incandescent light source: Ev = 100lux (see Figure 5)		125		Counts
	Incandescent light source: Ev = 1000lux (see Figure 5)		1120		
R _v illuminance responsivity	Sun light direct: 100 Ev = Lux (see Figure 6)		100		Counts
	Sun light direct: 1000 Ev = Lux (see Figure 6)		995		
R _v illuminance responsivity	Sun light shade (w/attenuating filter): Ev = 100lux (see Figure 7)		37		Counts
R _v illuminance responsivity	Sun light shade (w/attenuating filter): Ev = 1000lux (see Figure 7)		375		
Dark current	Ev = 0lux (see Figure 16)		To be provided		Counts

7.0 Device Operation

This device employs a sensitive photo diode which is fabricated in AMIS C3 standard CMOS process technology. The major components of this sensor are as shown in Figure 10. The photons which are to be detected are passed through an AMIS proprietary color filter. This color filter is used to limit all extraneous photons and thus perform a band pass filter operation on the incident wave front. Thus this filter transmits only those photons in the visible spectrum which are primarily detected by human eye. The photo response of this sensor is as shown in Figure 3.

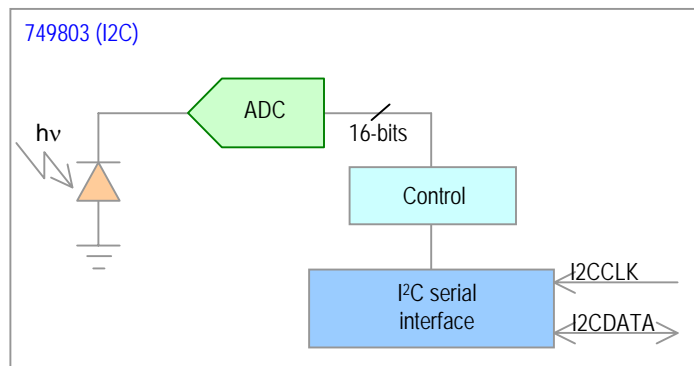

Figure 10: Block Diagram

The ambient light signal that is detected by the photo diode is converted to digital signal using a *variable slope integrating* ADC. The ADC that is used in this device has a maximum resolution of 16-bits unsigned value. The 16-bit ADC value is then provided to the control block which is also connected to the I²C interface block.

The following equation (eq-1) shows the relationship of output counts C_{nt} as a function of integration constant I_k , integration time T_i (in sec), and the intensity of the ambient light, I_L (in lux):

$$I_L = C_{nt} / (I_k * T_i) \quad \text{Equation 1}$$

where $I_k = 3.3357$

Hence the intensity of the ambient light, I_L (in lux):

$$I_L = C_{nt} / (3.3357 * T_i) \quad \text{Equation 2}$$

For example let:

$$\begin{aligned} C_{nt} &= 1001 \\ T_i &= 300\text{mS} \end{aligned}$$

Intensity of the ambient light, I_L (in lux):

$$I_L = 1001 / (3.3357 * 300\text{mS}) \quad \text{Equation 3}$$

$$I_L = 1000\text{lux}$$

8.0 I²C Interface

This device is capable of working as an I²C bus slave. Address of this device on I²C bus is always 0x39 (hexadecimal number 39). Registers of this device can be programmed by sending commands over I²C bus. Ambient light intensity count value can be obtained by reading registers of this device. Ambient light intensity count is a sixteen bits wide number and hence two I²C read operations are needed. This device supports both the standard mode (100 Kbit/s) and the fast mode (400 Kbit/s) of I²C. Figure 11 shows an I²C write operation. To write to an internal register of this device a command must be sent by an I²C master. As shown in Figure 11, the I²C write command begins with a start condition. After the start condition, seven bits of address are sent MSB first. RD/WR_ command bit follows the address bits. Upon receiving a valid address the device responds by driving I2CDATA low for an ACK. After receiving an ACK, I²C master sends eight bits of data with MSB first. Upon receiving eight bits of data the device generates an ACK. I²C master terminates this write command with a stop condition.

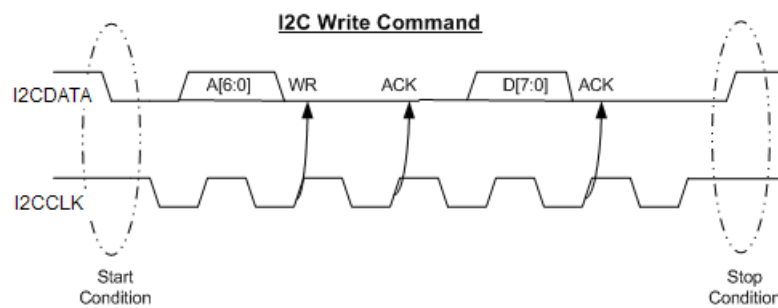

Figure 11: I²C Write Command

Figure 12 shows a I²C read command sent by the master to the slave device. I²C read command begins with a start condition. After the start condition seven bits of address are sent by the master MSB first. After the address bits, RD/WR_ command bit is sent. For a read command the RD/WR_ bits is high. Upon receiving the address bits and RD/WR_ command bits the device responds with an ACK. After sending an ACK, the device sends eight bits of data MSB first. After receiving the data master terminates this transaction by issuing a NACK command to indicate that the master only wanted to read one byte from the device. The master generates a stop condition to end this transaction.

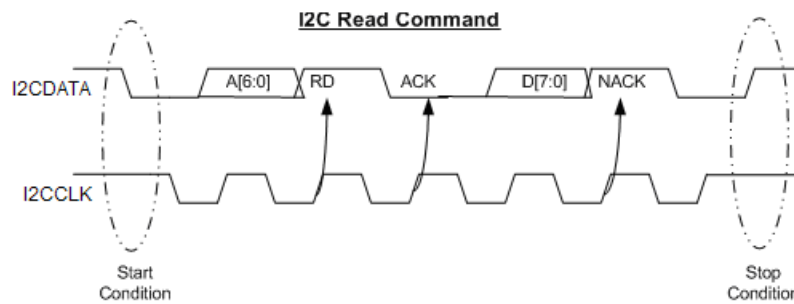

Figure 12: I²C Read Command

8.1 Programmer's Model

Ambient light intensity count is obtained from this chip by issuing a fixed sequence of I²C commands. Integration time of this device is programmable by writing different values to the integration time register. Sections below describe what a programmer needs to know about issuing commands to the chip and register access.

8.2 Integration Time Register

Table 5 describes integration time register. This register has three bits, EC[2:0]. Duration of integration time is controlled by these three bits.

Table 5: Integration Time Register

EC[2]	EC[1]	EC[0]	Operation	Integration Time
0	0	0	Normal mode of operation	400ms
0	0	1	Normal mode of operation	200ms (Default)
0	1	0	Normal mode of operation	100ms
0	1	1	Test mode	16.7ms
1	0	0	Simulation test mode use only	1.0ms
1	0	1	Reserved for future use	
1	1	0	Reserved for future use	
1	1	1	Reserved for future use	

8.3 Programming Sequence and Command Summary

This section describes supported commands and programming sequence. This device only supports single byte write and a single byte read I²C commands. Ambient light intensity count is a sixteen bits wide number. So to read the sixteen bits wide count, two I²C read commands are needed. Table 6 describes commands that this device supports. All of these commands have to be sent to a fixed address (0x39).

Table 6: Device Commands

Command	Function
0x00h	Start reading of ADC data
0x03h	Complete reading of ADC data
0x1Dh	Change EC[0] to 0
0x18h	Reset EC[2:0] to default value (001)
0x43h	Prepare ADC LS byte for reading
0x83h	Prepare ADC MS byte for reading
0x88h	Change EC[1] to 1
0x90h	Change EC[2] to 1

8.4 Programming Sequence

For reading sixteen bits wide Ambient light intensity count, please issue commands in the following sequence.

1. Send I2C write command 0x00h
2. Send I2C write command 0x03h (Steps 1 and 2 complete reading of ADC)
3. Send I2C write command 0x43h
4. Send I2C read byte command (Device returns LS byte of Count)
5. Send I2C write command 0x83h
6. Send I2C read byte command (Device returns MS byte of Count)

For changing integration time (for example to set integration time to 100ms), please issue commands in the following sequence:

1. Send I2C write command 0x1Dh (This command will toggle EC[0])
2. Send I2C write command 0x88h (This command will toggle EC[1], now EC[2:0] = 010)

9.0 Measurement Set-up

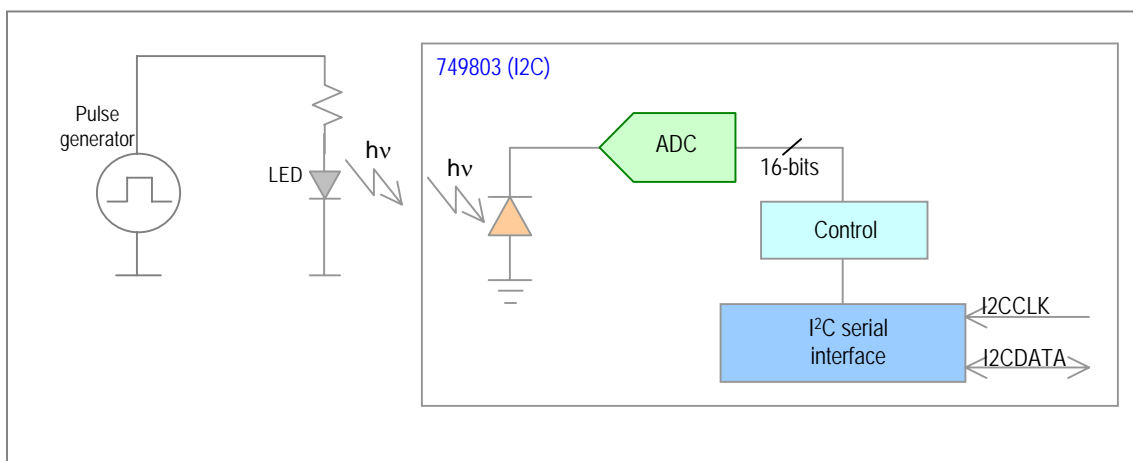
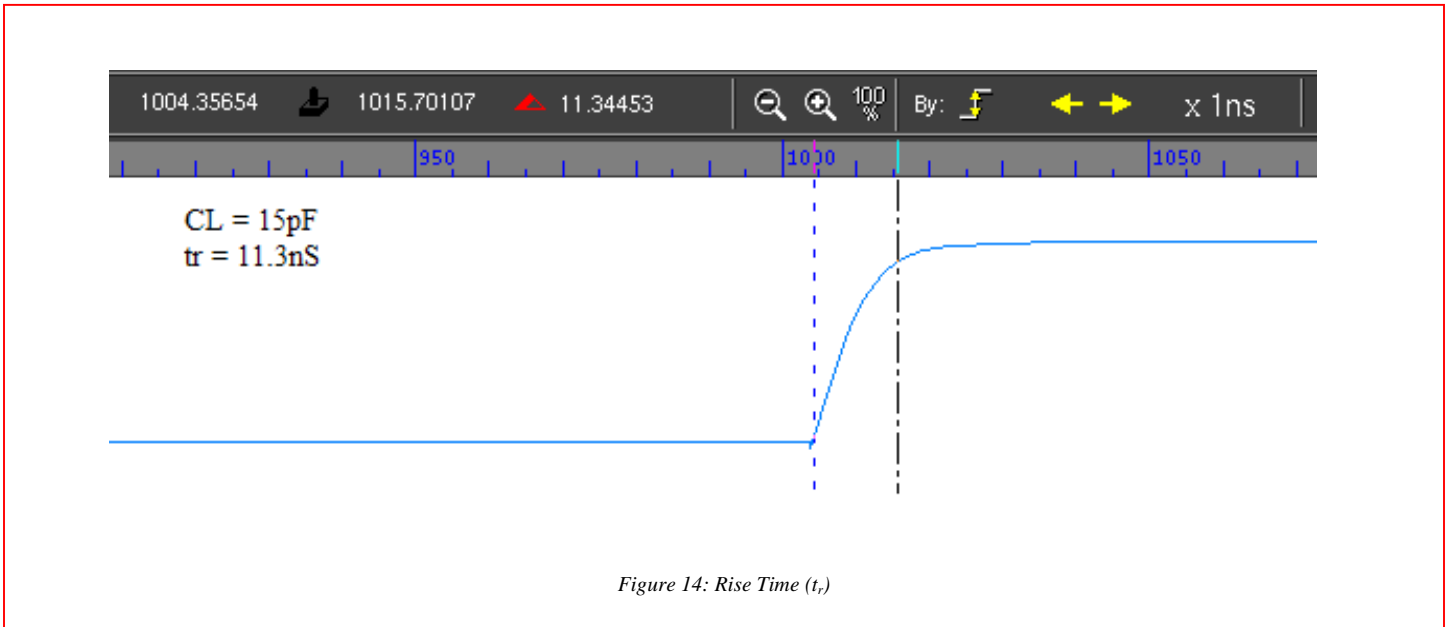

Figure 13: Measurement Set-up

9.1 Rise and Fall Time of I2CDATA (output)

9.1.1. Rise Time (t_r)

$C_L = 15\text{pF}$
 $t_r = 11.3\text{nS}$



9.1.2. Fall Time (t_f)

$C_L = 15\text{pF}$
 $t_f = 0.16\text{nS}$

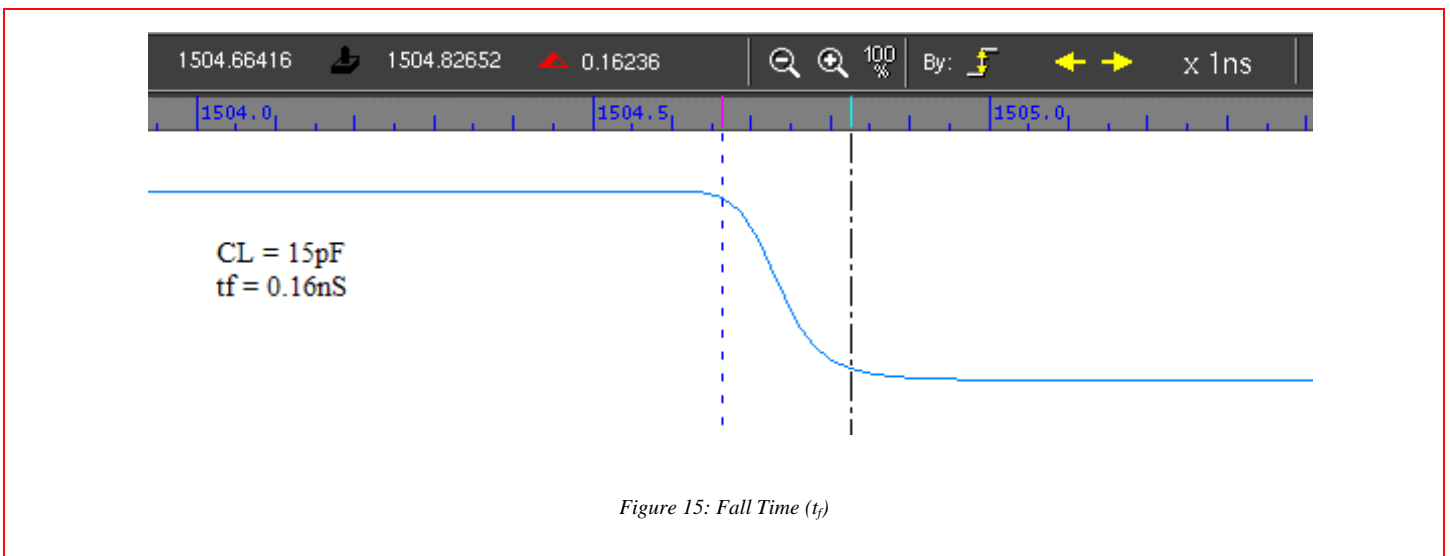

10.0 Characteristics

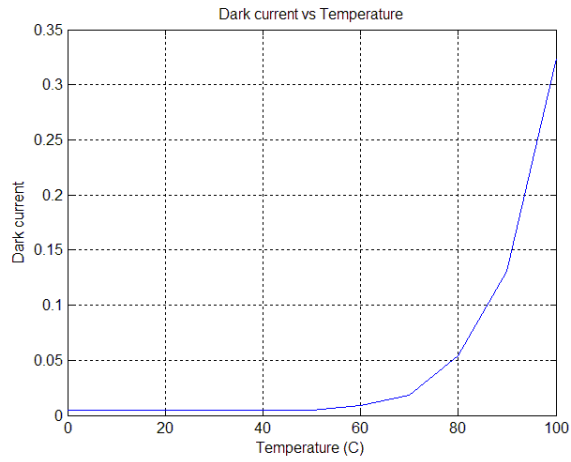

Figure 16: Dark Current vs. Temperature

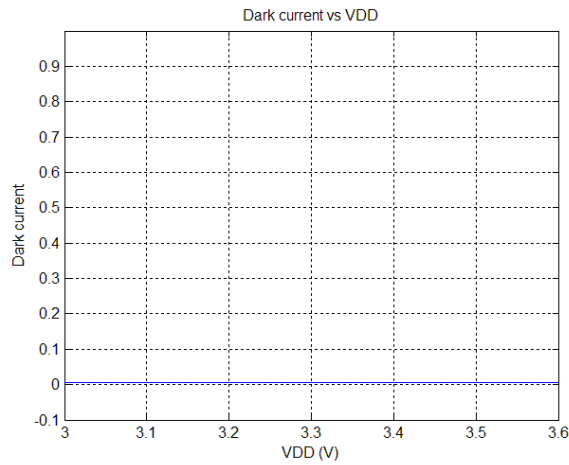

Figure 17: Dark Current vs. VDD

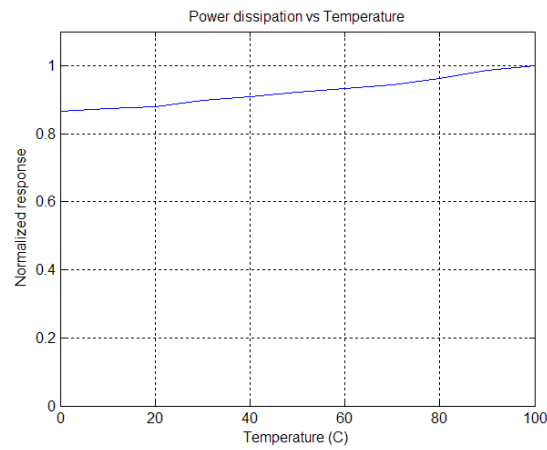

Figure 18: Power Dissipation vs. Temperature

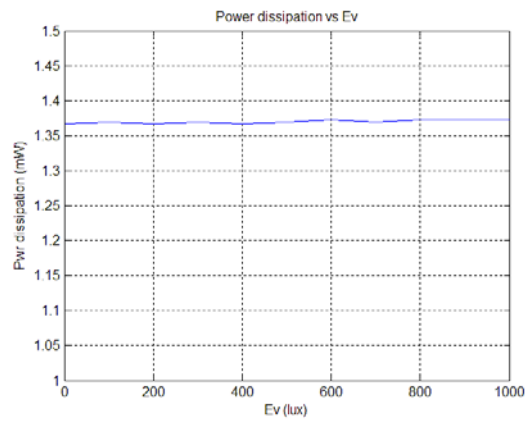

Figure 19: Power Dissipation vs. Ev

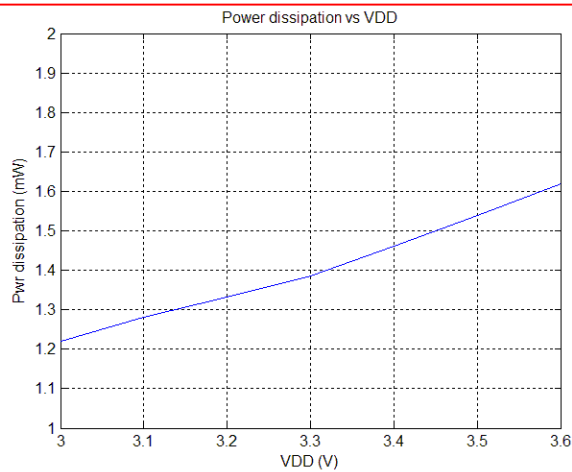

Figure 20: Power Dissipation vs. VDD

11.0 Application Information

Figure 21 and Figure 22 are illustrations of typical usage of the ALS device 749803 (I²C):

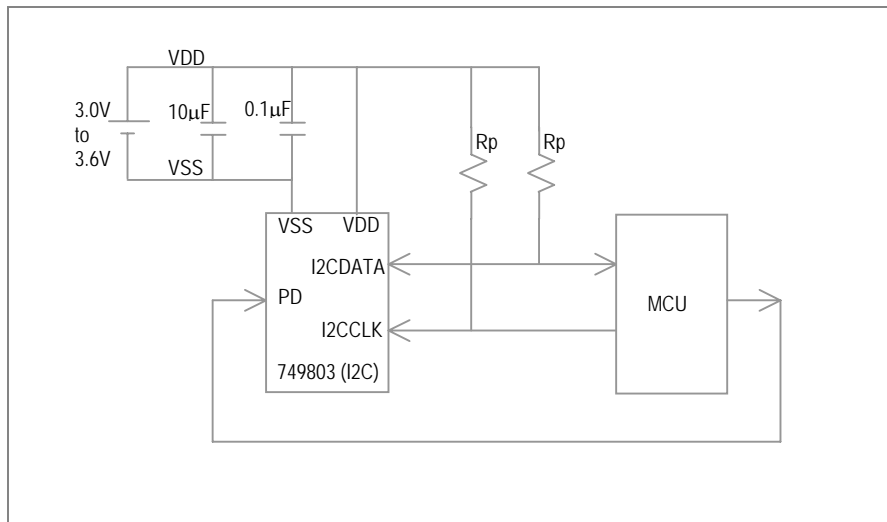

Figure 21: Typical usage, PD from MCU or SW control

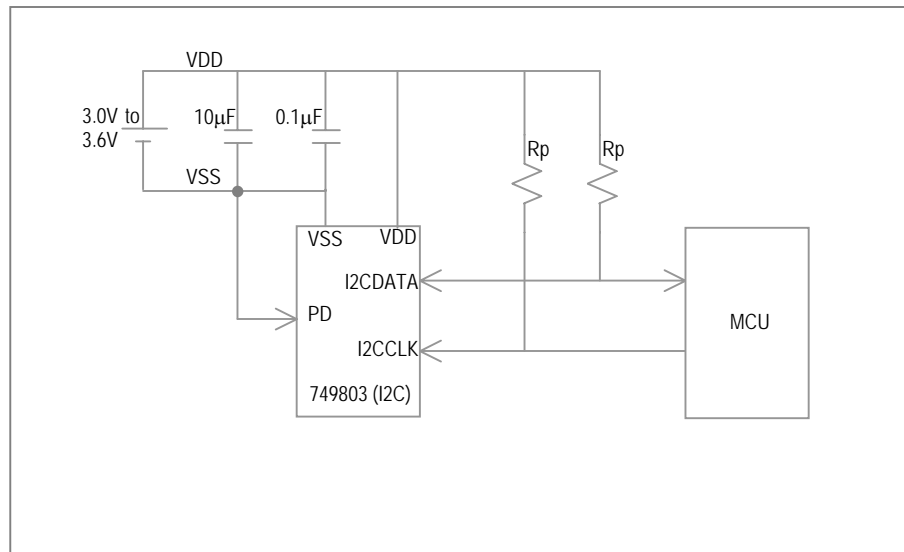

Figure 22: Typical usage, PD through SW control

12.0 Company or Product Inquiries

For more information about AMI Semiconductor's image sensors, please send an email to image_sensors@amis.com.

For more information about AMI Semiconductor's products or services visit our Web site at <http://www.amis.com>.

Production Technical Data - The information contained in this document applies to a product in production. AMI Semiconductor and its subsidiaries ("AMIS") have made every effort to ensure that the information is accurate and reliable. However, the characteristics and specifications of the product are subject to change without notice and the information is provided "AS IS" without warranty of any kind (express or implied). Customers are advised to obtain the latest version of relevant information to verify that data being relied on is the most current and complete. AMIS reserves the right to discontinue production and change specifications and prices at any time and without notice. Products sold by AMIS are covered by the warranty and patent indemnification provisions appearing in its Terms of Sale only. AMIS makes no other warranty, express or implied, and disclaims the warranties of noninfringement, merchantability, or fitness for a particular purpose. AMI Semiconductor's products are intended for use in ordinary commercial applications. These products are not designed, authorized, or warranted to be suitable for use in life-support systems or other critical applications where malfunction may cause personal injury. Inclusion of AMIS products in such applications is understood to be fully at the customer's risk. Applications requiring extended temperature range, operation in unusual environmental conditions, or high reliability, such as military or medical life-support, are specifically not recommended without additional processing by AMIS for such applications. Copyright © 2006 AMI Semiconductor, Inc.