



NEC's 1.5W GaAs MMIC POWER AMPLIFIER

UPG2118K

FEATURES

- **E-MODE HJ-FET TECHNOLOGY**
- **SINGLE +3.2V POWER SUPPLY**
- **HIGH EFFICIENCY:** PAE = 42% MIN
- **HIGH SATURATED POWER:** Pout = +31.5 dBm MIN
- **FLEXIBLE FREQUENCY RANGE**
- **20-PIN QFN PACKAGE:**
(4.15 x 4.15 x 0.9 mm)

DESCRIPTION

NEC's UPG2118K is a 1.5W, 3 stage power amplifier developed primarily for DCS/PCS1800 applications. With modified external matching the UPG2118K can be tuned from 800 to 2500 MHz.

Use of E-mode FET technology delivers high efficiency and high linearity with a single positive low voltage supply.

APPLICATIONS

- **1800 MHz DCS/PCS**
- **915 AND 2450 ISM BAND USAGE**
- **AUTOMATIC METER READERS**
- **WIRELESS SECURITY**
- **SATELLITE UPLINK**

ORDERING INFORMATION

PART NUMBER	MARKING	PACKAGE	SUPPLYING FORM
UPG2118K-E3	2118	20-pin QFN	<ul style="list-style-type: none"> • Embossed tape 12mm wide • 4.5 K pcs/reel

ABSOLUTE MAXIMUM RATINGS (TA = 25°C, unless otherwise specified)

PARAMETERS	SYMBOL	RATINGS	UNIT
Storage Temperature	T _{stg}	-45 to +85	°C
Operating Temperature	T _{opt}	-45 to +85	°C
Supply Voltage _{1,2,3}	V _D _{1,2,3}	8.0	V
Active Bias Circuit Voltage	V _{ABC}	8.0	V
Reference Voltage	V _{ref}	5.0	V
Junction Temperature	T _j	150	°C
Input Power	P _{in}	15	dBm
Total Power Dissipation	P _{tot}	4.0	W

Caution This device is ESD sensitive. Please take ESD precautions.

The information contained in this document is being issued in advance of the production cycle for the device. The parameters for the device may change before final production or NEC Corporation, at its own discretion, may withdraw the device prior to its production.

PIN CONNECTIONS

PIN NO.	CONNECTION	PIN NO.	CONNECTION
1	$V_{G1,2}$	11	GND
2	$V_{ref1,2}$	12	NC
3	V_{ABC}	13	NC
4	V_{ref3}	14	GND
5	V_{G3}	15	V_{D2}
6	GND	16	V_{D1}
7	$V_{D3}/RF\ OUT$	17	GND
8	$V_{D3}/RF\ OUT$	18	GND
9	$V_{D3}/RF\ OUT$	19	V_{attn}
10	$V_{D3}/RF\ OUT$	20	RF IN

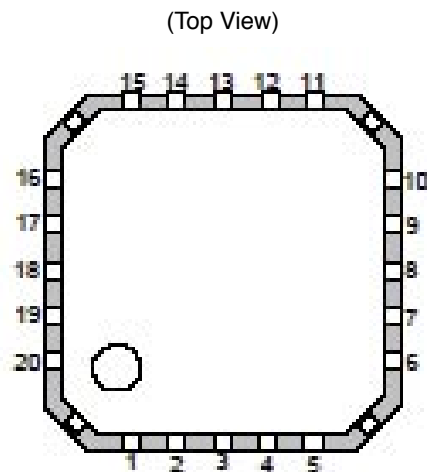

RECOMMENDED OPERATING CONDITIONS (TA = 25°C)

PARAMETERS	SYMBOL	MIN	TYP	MAX	UNIT
Supply Voltage	$V_{D1,2,3}$	+2.8	+3.2	+5.5	V
Reference Voltage	V_{ref}	+0.04	-	+1.8	V
Active Bias Circuit Voltage	V_{ABC}	0	2.6	5.5	V
Input Power	P_{in}	5	-	10	dBm

ELECTRICAL CHARACTERISTICS

(Unless otherwise specified, TA=+25°C, f=1880MHz, $V_{D1,2,3}$ =+3.2V, V_{ABC} =+2.6V, $V_{ref}=V_{attn}$ =1.8V, P_{in} =+5dBm)

CHARACTERISTICS	SYMBOL	TEST CONDITIONS	MIN	TYP	MAX	UNIT
Active Bias Circuit Current	I_{ABC}	P_{out} =+31.5dBm, V_{ABC} =Arbitrary	-	-	30	mA
Reference Current	I_{ref}	$V_{ref}=V_{attn}$ =0.04 to 1.8V	-	-	10	mA
RF Leakage Current	I_{leak}	$V_{ref}=V_{attn}$ =0.04 V V_{ABC} =10K ohm+Load	-	-	50	mA
Output Power	P_{out}		+31.5	-	-	dBm
Power Added Efficiency	PAE		42.0	-	-	%
Power Control Slope	P_{slope}	$V_{ref}=V_{attn}$ =0.04 V to 1.8V ΔV_{ref} =0.01V	-	-	50:1	Vrms/ Vref
Minimum Output Power	M_{Pout}	$V_{ref}=V_{attn}$ =0.04 V	-	-	-20	dBc

TEST CIRCUIT

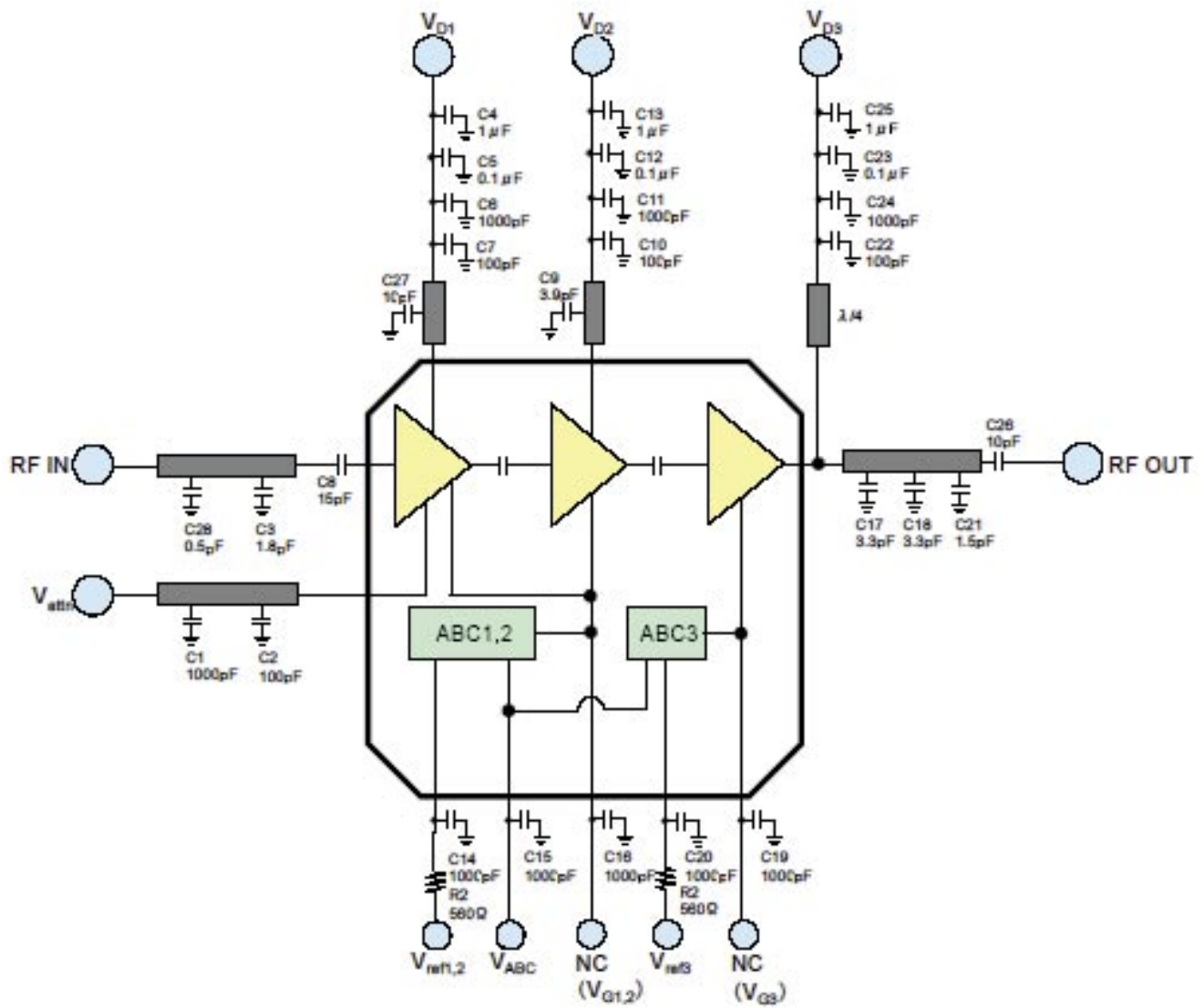

NC (VG1,2 VG3) These pins must be connected to ground via a 1000pF capacitor for stability.

PACKAGE DIMENSIONS (UNIT: mm)

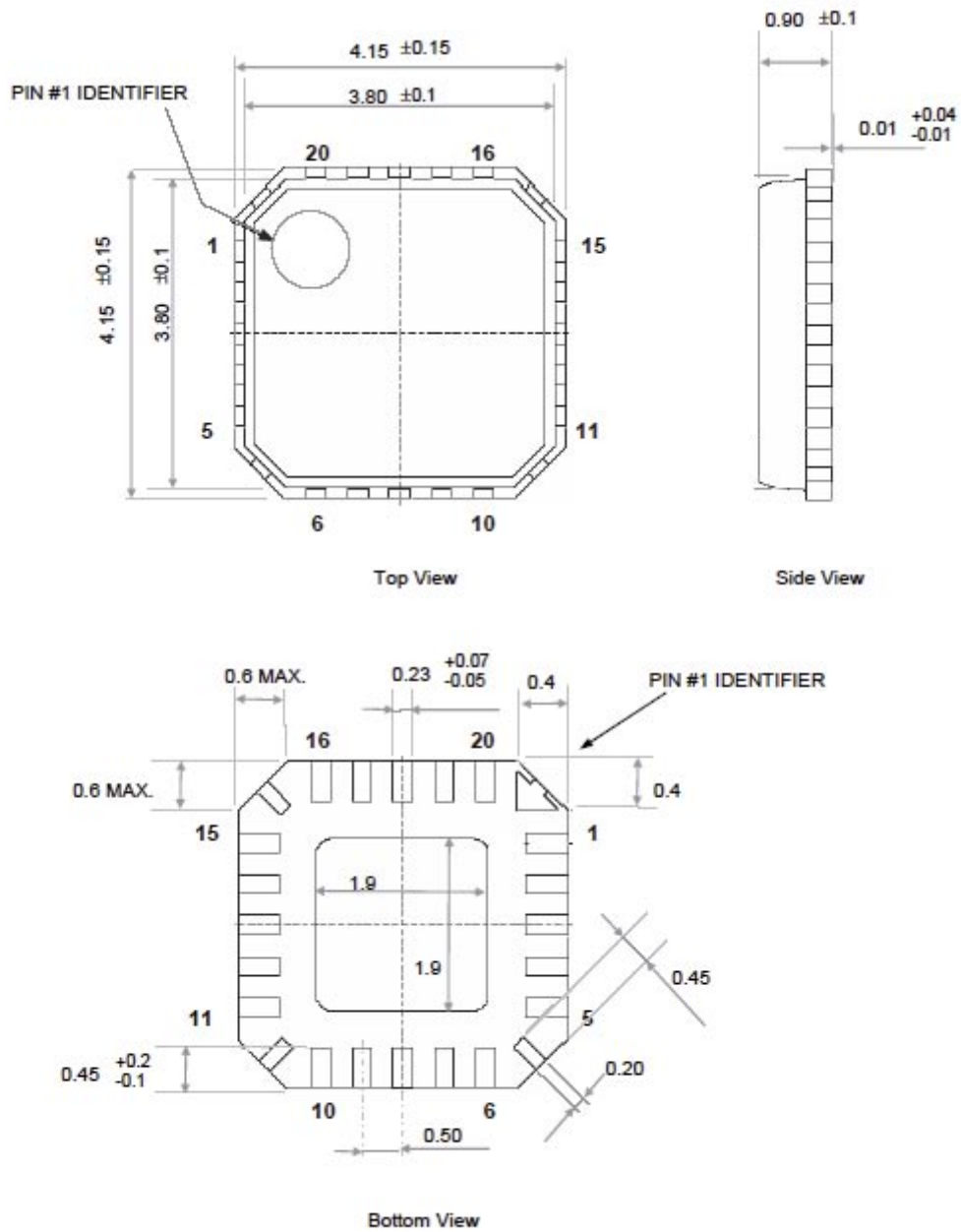

Life Support Applications

These NEC products are not intended for use in life support devices, appliances, or systems where the malfunction of these products can reasonably be expected to result in personal injury. The customers of CEL using or selling these products for use in such applications do so at their own risk and agree to fully indemnify CEL for all damages resulting from such improper use or sale.

CEL California Eastern Laboratories, Your source for NEC RF, Microwave, Optoelectronic, and Fiber Optic Semiconductor Devices.

4590 Patrick Henry Drive • Santa Clara, CA 95054-1817 • (408) 988-3500 • FAX (408) 988-0279 • www.cel.com

DATA SUBJECT TO CHANGE WITHOUT NOTICE

04/11/2005