



The Future of Analog IC Technology®

EV2106DQ/DK-00A

2.6V to 15V IN, 1.5A OUT Synchronous Buck Converter Evaluation Board

GENERAL DESCRIPTION

The EV2106DQ/DK-00A is an evaluation board designed to demonstrate the abilities of the MP2106DQ and MP2106DK synchronous buck converters, respectively. It can convert an input voltage with a range of 2.6V to 15V to a lower output voltage from 0.9V while delivering 1.5A to the load. The output voltage is preset to 1.8V, but can be easily be adjusted to other levels from 0.9V.

Fault condition protection includes cycle-by-cycle current limiting, thermal shutdown and under voltage lockout. The part's current mode control, high switching frequency and integrated high-side and low-side power MOSFETs, combined with tiny 10-pin MSOP or QFN packages, provide a solution requiring a minimum of components, board area and cost.

ELECTRICAL SPECIFICATIONS

Parameter	Symbol	Value	Units
Input Voltage	V_{IN}	2.6 to 15	V
Output Current	I_{LOAD}	1.5	A

FEATURES

- Up to 1.5A Continuous Output Current
- Wide 2.6V to 15V Operating Input Range
- Internal Power Switches
- 800KHz Fixed Switching Frequency
- All Ceramic Input and Output Capacitors
- Programmable Soft-Start
- Programmable Input Under Voltage Lockout

APPLICATIONS

- SOHO Routers, PCMCIA Cards, Mini PCI
- Handheld Computers
- PDAs
- Cellular Phones
- Digital Still and Video Cameras
- Small LCD Displays

"MPS" and "The Future of Analog IC Technology", are Registered Trademarks of Monolithic Power Systems, Inc.

EV2106DQ/DK-00A EVALUATION BOARD

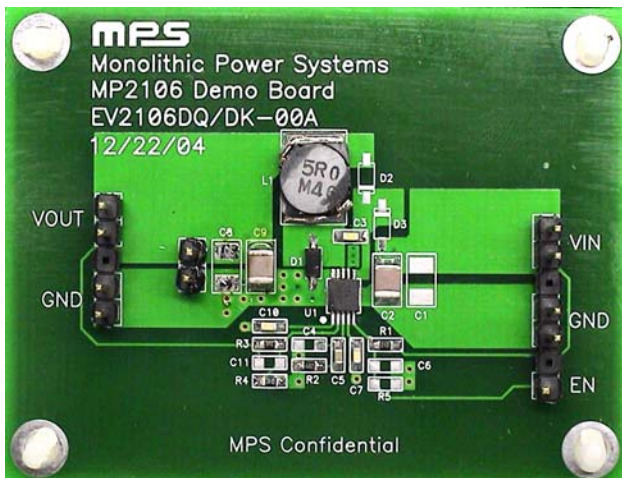

Dimensions (2.4"X x 1.8"Y x 0.4"Z)

Board Number	MPS IC Number
EV2106DQ/DK-00A	MP2106DQ/DK

Efficiency Curve

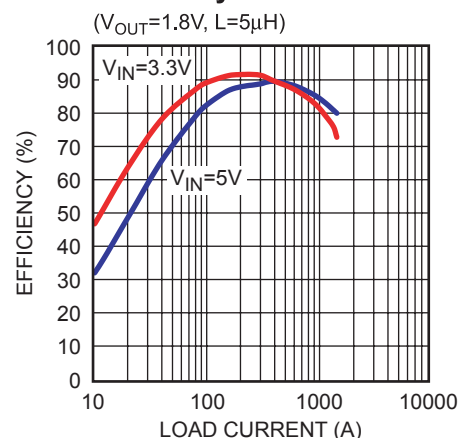

MP2106_TAC_EC02

EVALUATION BOARD SCHEMATIC

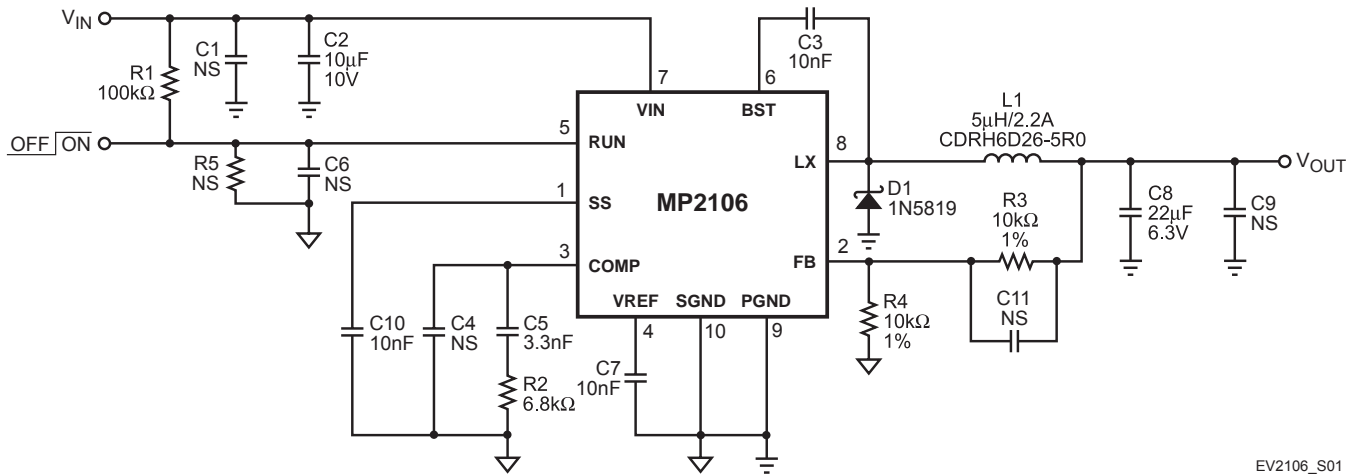

EV2106_S01

EV2106DQ/DK-00A BILL OF MATERIALS

Qty	Ref	Value	Description	Package	Manufacturer	Manufacturer P/N
5	C1, C4, C6, C9, C11		Do Not Stuff			
1	C2 ⁽¹⁾	10μF	Ceramic Cap, 10V, X7R	SM1210	AVX	1210ZC106KAT2A
1	C8	22μF	Ceramic Cap, 6.3V, X5R	SM1210	TDK	C3225X5R0J226M
3	C3, C7, C10	10nF	Ceramic Cap, 50V, X7R	SM0805	AVX	08055C103KAT2A
1	C5	3.3nF	Ceramic Cap, 50V, X7R	SM0805	AVX	08055C332KAT2A
1	D1		Schottky Diode, 40V, 1A	SOD123	Diodes Inc	1N5819HW-7
1	L1	5μH	Inductor, 2.2A	SMD	Sumida	CDRH6D26-5R0
1	R1	100kΩ	Film Res, 5%	SM0805	Panasonic	ERJ-6GEYJ104V
1	R2	6.8kΩ	Film Res, 5%	SM0805	Panasonic	ERJ-6GEYJ682V
2	R3, R4	10kΩ	Film Res, 1%	SM0805	Panasonic	ERJ-6ENF1002V
1	R5		Do Not Stuff			
1	U1		DC-DC Converter	QFN10	MPS	MP2106DQ

Note:

1) For $V_{IN} > 10V$, use a 16V capacitor for C2.

PRINTED CIRCUIT BOARD LAYOUT

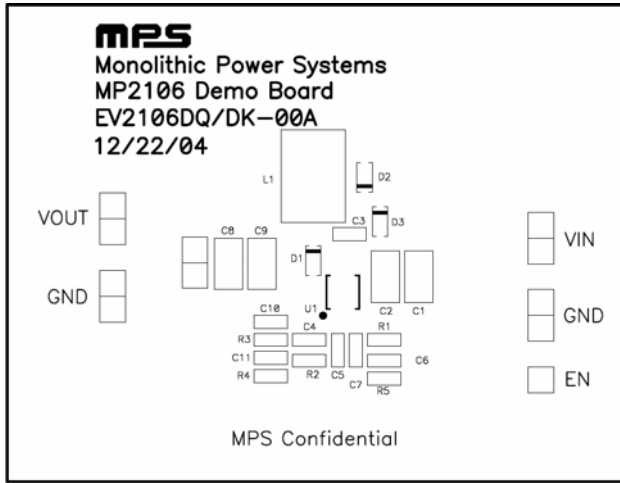

Figure 1—Top Silk Layer

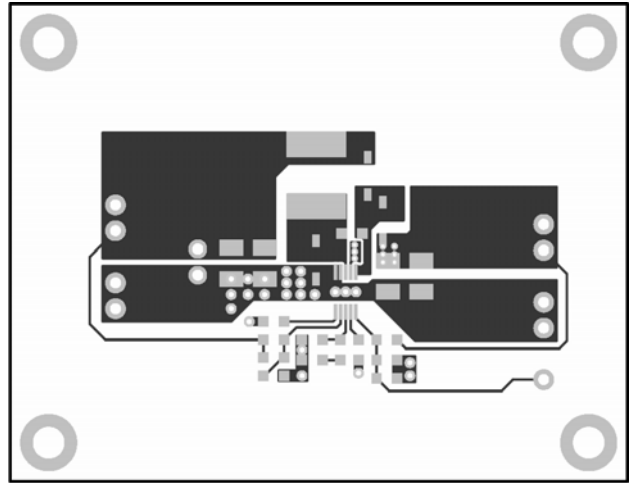

Figure 2—Top Layer

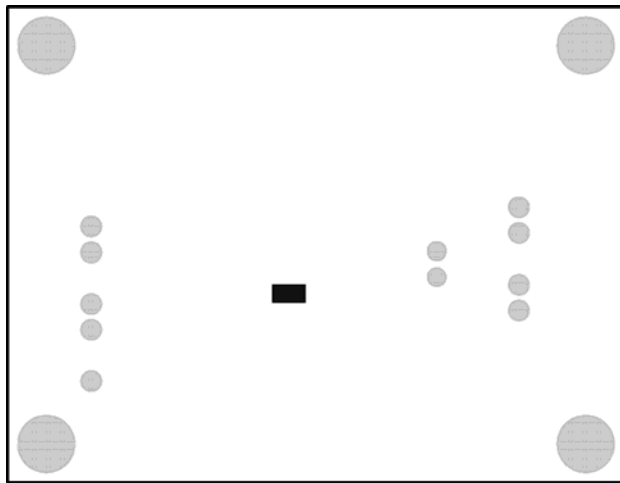

Figure 3—Bottom Silk Layer

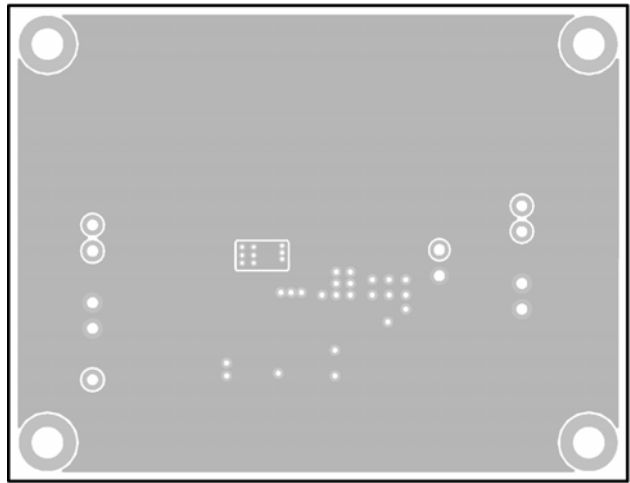

Figure 4—Bottom Layer

QUICK START GUIDE

The output voltage of this board is set to 1.8V. The board layout accommodates most commonly used inductors and output capacitors.

1. Attach positive end and negative end of load to OUT and GND pins, respectively.
2. Attach input voltage ($2.6V \leq V_{IN} \leq 13.5V$) and input ground to IN and GND pins, respectively.
3. A pull-up resistor has connected the EN pin to the IN pin, so the MP2106 will startup automatically without applying an external voltage to the EN pin.
4. The output voltage V_{OUT} can be changed by varying R3. Calculate the new value using the formula:

$$R3 = R4 \times \left(\frac{V_{OUT}}{V_{FB}} - 1 \right)$$

where $V_{FB} = 0.9V$ and $R4 = 10k\Omega$.

For example, for $V_{OUT} = 2.5V$:

$$R3 = R4 \times \left(\frac{V_{OUT}}{V_{FB}} - 1 \right) = 10k\Omega \times \left(\frac{2.5V}{0.9V} - 1 \right) = 17.78k\Omega \sim 17.8k\Omega$$

for the closest standard 1% value.

See Maximum Duty Cycle limits to determine allowable output voltages.

NOTICE: The information in this document is subject to change without notice. Please contact MPS for current specifications. Users should warrant and guarantee that third party Intellectual Property rights are not infringed upon when integrating MPS products into any application. MPS will not assume any legal responsibility for any said applications.